

The unfolding of general Petri nets

Jonathan Hayman Glynn Winskel
Computer Laboratory, University of Cambridge, England

Abstract

The unfolding of (1-)safe Petri nets to occurrence nets is well understood. There is a universal characterization of the unfolding of a safe net which is part and parcel of a coreflection from the category of occurrence nets to the category of safe nets. The unfolding of general Petri nets, nets with multiplicities on arcs whose markings are multisets of places, does not possess a directly analogous universal characterization, essentially because there is an implicit symmetry in the multiplicities of general nets, and that symmetry is not expressed in their traditional occurrence net unfoldings. In the present paper, we show how to recover a universal characterization by placing a symmetry on the occurrence net unfoldings of general Petri nets. We show that this is part of a coreflection between enriched categories of general Petri nets with symmetry and occurrence nets with symmetry.

1 Introduction

There is a wide array of models for concurrency. In [16], it is shown how category theory can be applied to describe the relationships between them by establishing coreflections, adjunctions in which the unit is an isomorphism, between their categories. This leads to uniform ways of defining constructions on models and provides links between concepts such as bisimulation in the models [5].

Petri nets are a widely-used model for concurrency. They play a fundamental role analogous to that of transition systems, but, by capturing the effect of events on *local* components of state, it becomes possible to describe how events might occur concurrently, how they might conflict with each other and how they might causally depend on each other. Here, we establish a relationship between general forms of Petri net and occurrence nets, a class of net suited to connecting nets to other models for concurrency.

Only partial results have been achieved in relating Petri nets to other models for concurrency since, in general, there is no coreflection between occurrence nets and more general forms of net that allow transitions to deposit more than one token in any place or in which a place can initially hold more than one token. The reason for this, as we shall see, is that the operation of unfolding such a net to form its associated occurrence net does not account for the *symmetry* in the behaviour of the original net due to places being marked more than once. In this paper, we define a symmetry on the unfolding and use this to obtain a coreflection between general nets and occurrence nets *up to symmetry*.

Of course, there are undoubtedly several ways of adjoining symmetry to nets. The method we use was motivated by the need to extend the expressive power of event structures and the maps between them [14, 15]. Roughly, a symmetry on a Petri net is described as a relation between its runs as causal nets, the relation specifying when one run is similar to another up to symmetry; of course, if runs are to be similar then they should have similar futures as well as pasts. Technically and generally, a relation of symmetry is expressed as a span of open maps which form a pseudo equivalence.

This general algebraic method of adjoining symmetry is adopted to define symmetry on nets, which we use to relate the categories of general nets with symmetry and occurrence nets

with symmetry. Another motivation for this work is that Petri nets provide a useful testing ground for the general method of adjoining symmetries. For example, the present work has led us to drop the constraint in [14, 15] that the morphisms of the span should be jointly monic, in which case the span would be an equivalence rather than a pseudo equivalence. (A similar issue is encountered in the slightly simpler setting of nets without multiplicities [4].) Motivated by the categories of nets encountered, the method for adjoining symmetry is also extended to deal with more general forms of model such as those without all pullbacks.

2 Varieties of Petri nets

We begin by introducing Petri nets. It is unfortunately beyond the scope of the current paper to give anything but the essential definitions of the forms of net that we shall consider; we instead refer the reader to [9, 16] for a fuller introduction. We make use of some basic multiset operations defined in Appendix A, though a fuller treatment can be found in the appendix of [13].

A Petri net consists of a set of *places* and a set of *transitions*, and possesses an appealing graphical interpretation in which its places are drawn as circles and its transitions are drawn as rectangles. Some (possibly infinite) number of *tokens*, drawn as dots, may reside inside each place, forming an ∞ -multiset of places called a *marking*. Arcs labelled with a natural number may be drawn from a place into a transition, indicating the finite number of tokens in the place that are consumed by the occurrence of the transition. Arcs labelled with a natural number or ∞ may be drawn from a transition to a place, indicating the number of tokens to be deposited in the place by the occurrence of an event. For example, the net

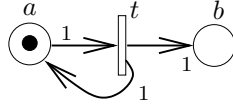

has two places, a and b , and one transition, t , which consumes a token from place a and deposits a token in both a and b . The marking of the net has one token in place a . More formally:

Definition 1 (General Petri net) A general Petri net is a 5-tuple,

$$G = (P, T, Pre, Post, \mathbb{M}),$$

comprising a set P of *places*; a set T of *transitions* disjoint from P ; a *pre-place* multirelation, $Pre \subseteq_{\mu} T \times P$; a *post-place* ∞ -multirelation, $Post \subseteq_{\mu\infty} T \times P$; and a set \mathbb{M} of ∞ -multisets of P forming the set of *initial markings* of G . Every transition must consume at least one token:

$$\forall t \in T \exists p \in P. Pre[t, p] > 0. \quad \square$$

This is a mild generalization of the standard definition of Petri net in that we allow there to be a *set* of initial markings rather than just one initial marking, and will prove important later. In the case where a general net has precisely one initial marking, we say that the net is *singly-marked*.

The marking of the net changes through the occurrence of transitions according to what is commonly called the *token game* for nets. For any place p , the occurrence of a transition t in marking M consumes $Pre[t, p]$ tokens from p and deposits $Post[t, p]$ in p . The transition can only occur if $M[p]$, the number of tokens in p , is greater than or equal to $Pre[t, p]$. The token game extends to finite multisets of transitions, giving rise to a relation between markings labelled by a finite multiset of transitions $M \xrightarrow{X} M'$ defined¹ as

$$M \xrightarrow{X} M' \text{ iff } Pre \cdot X \leq M \text{ and } M' = M - Pre \cdot X + Post \cdot X.$$

¹Even though multiset subtraction may be undefined due to subtraction of infinity, $M - Pre \cdot X$ is always defined if $Pre \cdot X \leq M$ since X is finite and Pre is a multirelation rather than an ∞ -multirelation.

The transition relation yields a notion of *reachable marking*, saying that a marking M' is reachable if there is some initial marking M from which, following some finite sequence of transitions, the marking M' is obtained.

A morphism of general nets embeds the structure of one net into that of another in way that preserves the token game — see [13], where they were introduced, for a full introduction.

Definition 2 (Net morphisms) Let $G = (P, T, Pre, Post, \mathbb{M})$ and $G' = (P', T', Pre', Post', \mathbb{M}')$ be general Petri nets. A morphism $(\eta, \beta) : G \rightarrow G'$ is a pair consisting of a partial function $\eta : T \rightarrow_* T'$ and an ∞ -multirelation $\beta \subseteq_{\mu\infty} P \times P'$ which jointly satisfy:

- for all $M \in \mathbb{M}$: $\beta \cdot M \in \mathbb{M}'$
- for all $t \in T$: $\beta \cdot (Pre \cdot t) = Pre' \cdot \eta(t)$ and $\beta \cdot (Post \cdot t) = Post' \cdot \eta(t)$ □

We write $\eta(t) = *$ if $\eta(t)$ is undefined and in the above requirement regard $*$ as the empty multiset, so that if $\eta(t) = *$ then $\beta \cdot (Pre \cdot t)$ and $\beta \cdot (Post \cdot t)$ are both empty.

The category of general Petri nets with multiple initial markings is denoted **Gen**, and we denote by **Gen_s** the category of singly-marked general nets (nets with one initial marking).

One simplification of general nets is to require that multirelations Pre and $Post$ are *relations* rather than (∞) -multirelations and that every initial marking must be a *set* of places rather than an ∞ -multiset. Transitions therefore take at most one token from any place and deposit at most one token in any place. We shall call such nets *P/T nets*, and define the category **PT** to have P/T nets as objects with the morphisms described above. We also define the category **PT_s** to consist of singly-marked P/T nets. The relations Pre and $Post$ of a P/T net $G = (P, T, Pre, Post, \mathbb{M})$ may equivalently be seen as a *flow relation* $F_G \subseteq (P \times T) \cup (P \times T)$ describing how places and transitions are connected:

$$p F_G t \stackrel{\Delta}{\iff} Pre(p, t) \quad t F_G p \stackrel{\Delta}{\iff} Post(t, p).$$

Any P/T net can therefore be defined as a 4-tuple $G = (P, T, F_G, \mathbb{M})$ by giving its flow relation. When writing the flow relation, we shall omit the subscript G where no confusion arises. We shall use x and y to range over elements of $P \cup T$ and write $x \in G$ to mean that $x \in P \cup T$. As standard, we write F^* for the reflexive, transitive closure of F and F^+ for the irreflexive, transitive closure of F . We say that y is *reachable* from x iff $x F^+ y$.

An important property that a P/T net can possess is (1-)*safety*, which means that any reachable marking is a set (*i.e.* there is no reachable marking that has more than one token in any place). We call such nets *safe nets*, and reserve the symbol N to range over them. Not every P/T net is safe: the net drawn above, for example, has two tokens in place b after two occurrences of t . We will call the transitions of safe nets *events* and their places *conditions*, writing (B, E, F, \mathbb{M}) for a safe net. We call $b \in B$ a *pre-condition* of $e \in E$ if $b F e$ and call b a *post-condition* of e if $e F b$. The set of pre-conditions of e is written $\bullet e$ and the set of postconditions of e is written $e \bullet$. The sets $\bullet b$ and $b \bullet$, of *pre-events* and *post-events* respectively of a condition b , are defined similarly. We denote the category of safe nets **Safe** and singly-marked safe nets **Safe_s**, with morphisms as described above.

Safe nets can be refined further to obtain *occurrence nets*. These were introduced in [8] as a class of net suited to giving the semantics of more general kinds of net in a way that represents the causal dependencies of event occurrences and how they conflict with each other due to the encountered markings of conditions. Occurrence nets provide a convenient link between more general forms of net and other models for concurrency. In [11, 12], a coreflection between (singly-marked) occurrence nets and a category of event structures was given, and there is a coreflection between the category of occurrence nets and (coherent) asynchronous transition systems [16]. We extend their original definition to account for the generalization to having a set of initial markings.

Definition 3 (Occurrence net) An *occurrence net* $O = (B, E, F, \mathbb{M})$ is a safe net satisfying the following restrictions.

1. $\forall M \in \mathbb{M} : \forall b \in M : (\bullet b = \emptyset)$
2. $\forall b' \in B : \exists M \in \mathbb{M} : \exists b \in M : (b F^* b')$
3. $\forall b \in B : (|\bullet b| \leq 1)$
4. F^+ is irreflexive and, for all $e \in E$, the set $\{e' \mid e' F^* e\}$ is finite.
5. $\#$ is irreflexive, where

$$\begin{aligned}
e \#_m e' &\stackrel{\Delta}{\iff} e \in E \ \& \ e' \in E \ \& \ e \neq e' \ \& \ \bullet e \cap \bullet e' \neq \emptyset \\
b \#_m b' &\stackrel{\Delta}{\iff} \exists M, M' \in \mathbb{M} : (M \neq M' \ \& \ b \in M \ \& \ b' \in M') \\
x \#_m x' &\stackrel{\Delta}{\iff} \exists y, y' \in E \cup B : y \#_m y' \ \& \ y F^* x \ \& \ y' F^* x' \quad \square
\end{aligned}$$

Singly-marked occurrence nets can be seen to coincide with the original definition of occurrence net. We denote the category of occurrence nets **Occ** and the category of singly-marked occurrence nets **Occ_s**, both with morphisms as described above.

By ensuring that any condition occurs as the postcondition of at most one event, the constraints above allow the flow relation F to be seen to represent causal dependency. Since the flow relation is required to be irreflexive, as is the *conflict* relation $\#$, every condition can occur in some reachable marking and every event can take place in some reachable marking. Two elements of the occurrence net are in conflict if the occurrence of one precludes the occurrence of the other at any later stage.

The *concurrency* relation $\text{co}_O \subseteq (B \cup E) \times (B \cup E)$, indicating that two elements of the occurrence net are concurrent (may occur at the same time in some reachable marking) if they neither causally depend on nor conflict with each other, is defined as:

$$x \text{co}_O y \stackrel{\Delta}{\iff} \neg(x \# y \text{ or } x F^+ y \text{ or } y F^+ x)$$

We often drop the subscript O when we write co_O . The concurrency relation is extended to sets of conditions A in the following manner:

$$\text{co } A \stackrel{\Delta}{\iff} (\forall b, b' \in A : b \text{co } b') \text{ and } \{e \in E \mid \exists b \in A. e F^* b\} \text{ is finite}$$

Proposition 1 Let $O = (B, E, F, \mathbb{M})$ be an occurrence net. Any subset $A \subseteq B$ satisfies $\text{co } A$ iff there exists a reachable marking M of O such that $A \subseteq M$. \square

The final class of net that we shall make use of is *causal* nets. These are well-known representations of paths of general nets, recording how a set of consistent events (events that do not conflict) causally depend on each other through the encountered markings of conditions.

Definition 4 (Causal net) A causal net $C = (B, E, F, \mathbb{M})$ is an occurrence net with at most one initial marking for which the conflict relation $\#$ is empty. \square

2.1 Unfolding

As discussed above, occurrence nets can be used to give the semantics of more general forms of net. The process of forming the occurrence net semantics of a net is called *unfolding*, first defined for safe nets in [8]. The result of unfolding a net N is an occurrence net $\mathcal{U}(N)$ accompanied by a morphism $\varepsilon_N : \mathcal{U}(N) \rightarrow N$ relating the unfolding back to the original net. An example unfolding is presented below, with the conditions and events of the unfolding labelled by their image under ε_N :

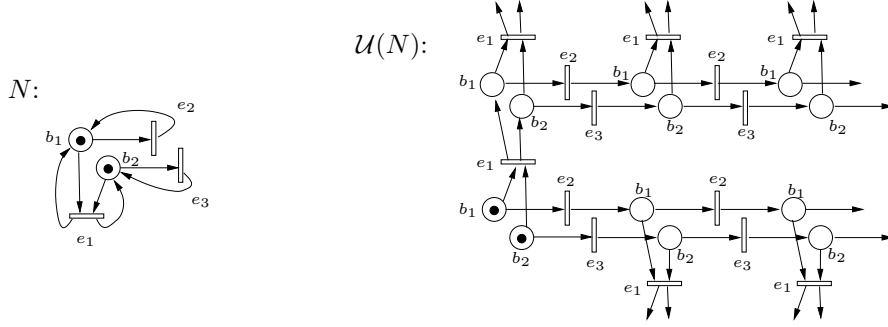

For a safe net N , we are able to say that the occurrence net $\mathcal{U}(N)$ and morphism $\varepsilon_N : \mathcal{U}(N) \rightarrow N$ are *cofree*. That is, for any occurrence net O and morphism $(\pi, \gamma) : O \rightarrow N$, there is a *unique* morphism $(\theta, \alpha) : O \rightarrow \mathcal{U}(N)$ such that the following triangle commutes:

$$\begin{array}{ccc}
 \mathcal{U}(N) & \xrightarrow{\varepsilon_N} & N \\
 (\theta, \alpha) \uparrow & \nearrow (\pi, \gamma) & \\
 O & &
 \end{array}$$

The result, first shown in [12] (for singly-marked nets; the generalization to multiply-marked nets is straightforward), ensures that **Occ** is a coreflective subcategory of **Safe** with the operation of unfolding giving rise to a functor that is right-adjoint to the inclusion functor $\mathbf{Occ} \hookrightarrow \mathbf{Safe}$. In fact, the result also applies to give a coreflection between the category of P/T nets, and more generally still to semi-weighted nets (nets with single multiplicity in the post-places of each transition and that have at most one token in each place in the initial marking) as shown in [6].

A coreflection is not, however, obtained when we consider the unfoldings of arbitrary general nets to occurrence nets (either singly- or multiply-marked). The problem does not lie in defining the unfolding of general nets. The way in which it is defined is slightly technical, as for defining the unfolding of safe nets involving an inductive definition, but it can be neatly uniquely characterized as follows:

Proposition 2 *The unfolding $\mathcal{U}(G) = (B, E, F, \mathbb{M}_0)$ of $G = (P, T, Pre, Post, \mathbb{M})$ is the unique occurrence net to satisfy*

$$\begin{aligned}
 B &= \{(M, p, i) \mid M \in \mathbb{M} \ \& \ p \in P \ \& \ 0 \leq i < M[p]\} \\
 &\quad \cup \{\{\{e\}, p, i\} \mid e \in E \ \& \ p \in P \ \& \ 0 \leq i < (Post \cdot \eta(e))[p]\} \\
 E &= \{(A, t) \mid A \subseteq B \ \& \ t \in T \ \& \ co \ A \ \& \ \beta \cdot A = Pre \cdot t\} \\
 b \ F \ (A, t) &\iff b \in A \\
 (A, t) \ F \ b &\iff \exists p, i : (b = (\{A, t\}, p, i)) \\
 \mathbb{M}_0 &= \{\{(M, p, i) \mid (M, p, i) \in B\} \mid M \in \mathbb{M}\},
 \end{aligned}$$

where co and $\#$ are the concurrency and conflict relations arising from F on B and E . Furthermore, $\eta : E \rightarrow P$ and $\beta : B \rightarrow P$ defined as

$$\eta(A, t) = t \quad \beta(X, p, i) = p$$

form a morphism $\varepsilon_G = (\eta, \beta) : \mathcal{U}(G) \rightarrow G$ in **Gen**, regarding the function β as a multirelation. \square

The reason why we do not obtain a coreflection between the categories \mathbf{Occ}_s and \mathbf{Gen}_s (or **Occ** and **Gen**) is the uniqueness property required for cofreeness fails. That is, the morphism (θ, α) need not be the unique such morphism making the diagram above commute. In Figure 1, we present a general net G , its unfolding $\mathcal{U}(G)$ with morphism ε_G and an occurrence net O (which happens to be isomorphic to $\mathcal{U}(G)$) with morphism $(\pi, \gamma) : O \rightarrow G$ alongside two distinct morphisms $(\theta, \alpha), (\theta', \alpha') : O \rightarrow \mathcal{U}(G)$ making the diagram commute.

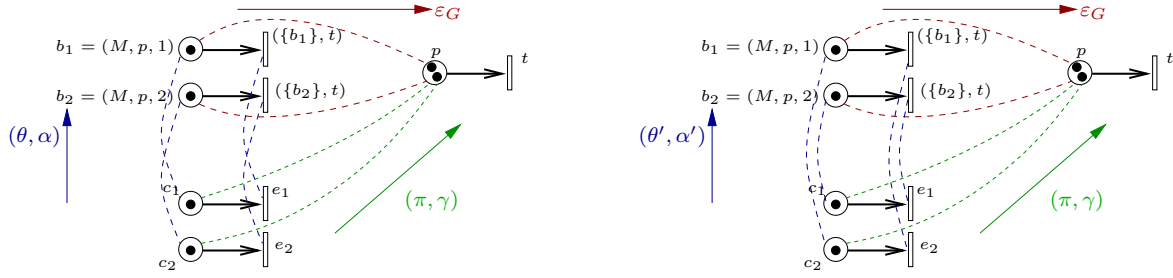

Figure 1: Non-uniqueness of mediating morphism (all multiplicities 1)

In the net $\mathcal{U}(G)$ in Figure 1, the two conditions b_1 and b_2 are symmetric: they arise from there being two indistinguishable tokens in the initial marking of G in the place p . The events $(\{b_1\}, t)$ and $(\{b_2\}, t)$ are also symmetric since they are only distinguished by their symmetric pre-conditions; they have common image under ε_G . Our goal shall be to show that there is a unique mediating morphism *up to symmetry*, *i.e.* any two morphisms from O to $\mathcal{U}(G)$ making the diagram commute are only distinguished through their choice of symmetric elements of the unfolding. We first summarize the part of the cofreeness property that does hold.

Theorem 1 *Let G be a general Petri net, O be an occurrence net and $(\pi, \gamma) : O \rightarrow G$ be a morphism in \mathbf{Gen} . There is a morphism $(\theta, \alpha) : O \rightarrow \mathcal{U}(G)$ in \mathbf{Gen} such that the following diagram commutes:*

$$\begin{array}{ccc}
 \mathcal{U}(G) & \xrightarrow{(\eta, \beta) = \varepsilon_G} & G \\
 (\theta, \alpha) \uparrow & & \nearrow (\pi, \gamma) \\
 O & &
 \end{array}$$

Furthermore, if the net G is a P/T net then (θ, α) is the unique such morphism. \square

It will be of use later to note that if the multirelation γ above is a function then so is α .

2.2 Pullbacks

The framework for defining symmetry on general nets, to be described in the next section, will require a subcategory which has pullbacks. Whereas it was shown in [3] that the category of singly-marked safe nets has pullbacks, the category of singly-marked general nets does not. Roughly, this is for two reasons: the category with multirelations as morphisms does not have pullbacks; and allowing only singly-marked nets obstructs the existence of pullbacks. It is the latter obstruction that led us to the earlier relaxation of the definition of nets, to permit them to have a set of initial markings rather than precisely one initial marking. To obtain a category of general nets with pullbacks, we restrict attention to *folding* morphisms between general nets (with multiple initial markings):

Definition 5 A morphism $(\eta, \beta) : G \rightarrow G'$ is a *folding* if both η and β are total functions. \square

Denote the category of general nets with folding morphisms \mathbf{Gen}_f , its full subcategory of occurrence nets \mathbf{Occ}_f , and the full subcategory of causal nets \mathbf{Caus}_f . The pullbacks are presented in Appendix B.

Proposition 3 *The category \mathbf{Gen}_f has pullbacks.* \square

The category \mathbf{Occ} has pullbacks, though we will only need pullbacks of folding morphisms. Pullbacks in \mathbf{Occ}_f are obtained by unfolding the corresponding pullbacks in \mathbf{Gen}_f : the construction of the pullback in \mathbf{Gen}_f ensures that it is a P/T net, so Theorem 1 allows us to show that the result is indeed the pullback in the category \mathbf{Occ}_f . The following lemma expresses how pullbacks in subcategories with folding morphisms are not disturbed in moving to larger

categories with all morphisms, though in the case of general nets we have to settle for them becoming weak pullbacks.²

Lemma 1 (i) *The inclusion functor $\mathbf{Occ}_f \hookrightarrow \mathbf{Occ}$ preserves pullbacks.*

(ii) *The inclusion functor $\mathbf{Occ}_f \hookrightarrow \mathbf{Gen}_f$ preserves pullbacks.*

(iii) *The inclusion functor $\mathbf{Gen}_f \hookrightarrow \mathbf{Gen}$ preserves weak pullbacks.* □

3 Categories with symmetry

It is shown in [14] how *symmetry* can be defined on event structures, and more generally on any category of models satisfying certain properties. The absence of pullbacks in the category \mathbf{Gen} obliges us to extend the method when introducing symmetry to general nets and their unfoldings.

The definition of symmetry makes use of *open* morphisms [5]. Let \mathcal{C}_0 be a category (typically a category of models such as Petri nets) with a distinguished subcategory \mathcal{P} of path objects (such as causal nets), to describe the shape of computation paths, and morphisms specifying how a path extends to another. A morphism $f : X \rightarrow Y$ in \mathcal{C}_0 is *\mathcal{P} -open* if, for any morphism $s : P \rightarrow Q$ in \mathcal{P} and morphisms $p : P \rightarrow X$ and $q : Q \rightarrow Y$, if the diagram

$$\begin{array}{ccc} P & \xrightarrow{p} & X \\ s \downarrow & & \downarrow f \\ Q & \xrightarrow{q} & Y \end{array}$$

commutes then there is a morphism $h : Q \rightarrow X$ such that the diagram

$$\begin{array}{ccc} P & \xrightarrow{p} & X \\ s \downarrow & \nearrow h & \downarrow f \\ Q & \xrightarrow{q} & Y \end{array}$$

commutes, *i.e.* $p = h \circ s$ and $q = f \circ h$. The path-lifting property expresses that via f any extension of a path in Y can be matched by an extension in X , and captures those morphisms f which are bisimulations, though understood generally with respect to a form of path specified by \mathcal{P} . It can be shown purely diagrammatically that open morphisms compose, and therefore form a subcategory, and are preserved under pullbacks in \mathcal{C}_0 .

Assume categories

$$\mathcal{P} \subseteq \mathcal{C}_0 \subseteq \mathcal{C}$$

where \mathcal{P} is a distinguished subcategory of path objects and path morphisms, \mathcal{C}_0 has pullbacks and shares the same objects as the (possibly larger) category \mathcal{C} , with the restriction that the inclusion functor $\mathcal{C}_0 \hookrightarrow \mathcal{C}$ preserves weak pullbacks. Then, we will be able to add symmetry to \mathcal{C} , and at the same time maintain constructions dependent on pullbacks of open morphisms, such as Lemma 2 below, which will be central to constructing symmetries on unfoldings.³ (The earlier method for introducing symmetry used in [14] corresponds to the situation where \mathcal{C}_0 and \mathcal{C} coincide.)

²Recall a *weak* pullback is defined in a similar way to a pullback, but without insisting on uniqueness of the mediating morphism.

³We have chosen general conditions that work for our purposes here. It might become useful to replace the role of $\mathcal{P} \subseteq \mathcal{C}_0$ by an axiomatization of a subcategory of open morphisms in \mathcal{C} and in this way broaden the class of situations in which we can adjoin symmetry.

The role of $\mathcal{P} \subseteq \mathcal{C}_0$ is to determine open morphisms; the role of the subcategory \mathcal{P} is to specify the form of path objects and extension, while the, generally larger, category \mathcal{C}_0 fixes the form of paths $p : P \rightarrow C$ from a path object P in an object C of \mathcal{C}_0 . Now, just as earlier, we can define open morphisms in \mathcal{C}_0 , and so in \mathcal{C} .

Now we show how \mathcal{C} can be extended with symmetry to yield a category \mathcal{SC} . The objects of \mathcal{SC} are tuples (X, S, l, r) consisting of an object X of \mathcal{C} and two \mathcal{P} -open morphisms $l, r : S \rightarrow X$ which make l, r a pseudo equivalence [1] (see Appendix C). The requirements on l and r are slightly weaker than those in [14] in that we do not require that the morphisms l and r are jointly monic.⁴

The morphisms of \mathcal{SC} are morphisms of \mathcal{C} that *preserve symmetry*. Let $f : X \rightarrow X'$ be a morphism in \mathcal{C} and (X, S, l, r) and (X', S', l', r') be objects of \mathcal{SC} . The morphism $f : X \rightarrow X'$ preserves symmetry if there is a morphism $h : S \rightarrow S'$ such that the following diagram commutes:

$$\begin{array}{ccccc} X & \xleftarrow{l} & S & \xrightarrow{r} & X \\ f \downarrow & & \downarrow h & & \downarrow f \\ X' & \xleftarrow{l'} & S' & \xrightarrow{r'} & X' \end{array}$$

With the definition of symmetry on objects, we can define the equivalence relation \sim expressing when morphisms are *equal up to symmetry*:

Let $f, g : (X, S, l, r) \rightarrow (X', S', l', r')$ be morphisms in \mathcal{SC} . Define $f \sim g$ iff there is a morphism $h : X \rightarrow X'$ in \mathcal{C} such that following diagram commutes in \mathcal{C} :

$$\begin{array}{ccc} & X & \\ f \swarrow & \downarrow h & \searrow g \\ X' & \xleftarrow{l'} S' \xrightarrow{r'} & X' \end{array}$$

Composition of morphisms in \mathcal{SC} coincides with composition in \mathcal{C} and the two categories share the same identity morphisms. The category \mathcal{SC} is more fully described as a category enriched in equivalence relations.

Later we make significant use of the following construction, the inverse image of a symmetry along an open morphism.

Lemma 2 *Given a symmetry l, r on B and an open morphism $f : A \rightarrow B$ in \mathcal{C} we obtain a symmetry l', r' on A as its inverse image along f , obtained via the following three pullbacks in \mathcal{C}_0 :*

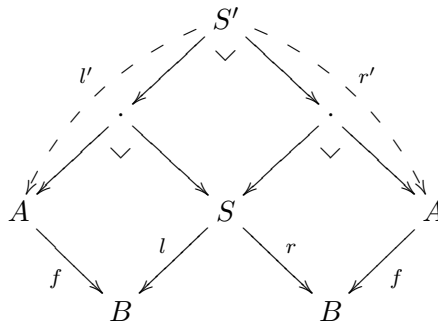

□

Lemma 2 depends crucially on the existence of pullbacks in \mathcal{C}_0 and the property that pullbacks of open morphisms are open (here weak pullbacks do not suffice) — without this we would not know that l' and r' were open.

For nets, a reasonable choice for the paths \mathcal{P} would be \mathbf{Caus}_f , taking path objects to be causal nets and expressing path extensions by foldings between them. (There are other possibilities, say restricting to finite causal nets, or the causal nets associated with finite elementary

⁴See [4] for an example of a symmetry on a safe net that cannot be expressed with the jointly-monic condition.

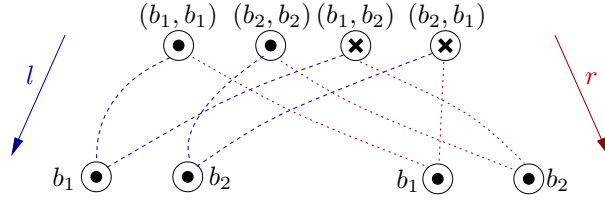

Figure 2: Symmetry on a net with two places

event structures, which would lead to less refined equivalences up to symmetry.) The categories

$$\mathbf{Caus}_f \subseteq \mathbf{Gen}_f \subseteq \mathbf{Gen}$$

meet the requirements needed to construct \mathbf{SGen} — in particular by Lemma 1 (iii), so adjoining symmetry to general nets. The requirements are also met by

$$\mathbf{Caus}_f \subseteq \mathbf{Occ}_f \subseteq \mathbf{Occ}$$

yielding \mathbf{SOcc} (this time using Lemma 1 (ii)).

4 Symmetry in unfolding

In Section 2.1, we showed how a general Petri net may be unfolded to form an occurrence net. This was shown not to yield a coreflection due to the mediating morphism not necessarily being unique. The key observation was that uniqueness might be obtained by regarding the net up to the evident symmetry on the unfolding. This led us to define a category of general nets with symmetry. To give an example of the forms of symmetry that can be expressed, consider the simple net with two places, b_1 and b_2 , both initially marked once. Suppose that we wish to express that the two places are symmetric; for instance, the net might be thought of as the unfolding of the general net with a single place initially marked twice. The span to express that symmetry is presented in Figure 2. Without our extension of the definition of net to allow multiple initial markings, this simple symmetry would be inexpressible. As we shall see, this accompanies the fact that the category of singly-marked general nets does not have pullbacks.

In general, the symmetry on an unfolding is obtained by unfolding the *kernel* of the morphism $\varepsilon_G : \mathcal{U}(G) \rightarrow G$, which is the pullback of ε_G against itself in \mathbf{Gen}_f :

$$\begin{array}{ccc} S & \xrightarrow{r} & \mathcal{U}(G) \\ \downarrow l & \lrcorner & \downarrow \varepsilon_G \\ \mathcal{U}(G) & \xrightarrow{\varepsilon_G} & G \end{array}$$

To see that $(\mathcal{U}(G), \mathcal{U}(S), l \circ \varepsilon_S, r \circ \varepsilon_S)$ is a symmetry, we must show that the morphisms $l \circ \varepsilon_S$ and $r \circ \varepsilon_S$ are \mathbf{Caus}_f -open and form a pseudo equivalence. The latter point follows a purely diagrammatic argument. Open morphisms from occurrence nets into general nets can be characterized in the following way:

Proposition 4 *Let O be an occurrence net and G be a general net. A morphism $f : O \rightarrow G$ is \mathbf{Caus}_f -open in \mathbf{Gen}_f if, and only if, it is total on conditions and events, reflects any initial marking of G to an initial marking of O and satisfies the following property:*

for any subset A of conditions of O such that $\text{co } A$ for which there exists a transition t of G such that $f \cdot A = \text{Pre}_G \cdot t$, there exists an event e of O such that $A = \text{Pre}_O \cdot e$ and $f(e) = t$. □

The morphism $\varepsilon_G : \mathcal{U}(G) \rightarrow G$ of Proposition 2 is readily seen to satisfy this property for any G , and is therefore **Caus_f**-open. The pullback of open morphisms is open [5] so the morphisms l and r are **Caus_f**-open, and therefore $l \circ \varepsilon_S$ and $r \circ \varepsilon_S$ are both open since open morphisms compose to form open morphisms [5]. Note that a morphism between occurrence nets is **Caus_f**-open in **Occ_f** iff it is **Caus_f**-open in **Gen_f**.

Proposition 5 *The tuple $(\mathcal{U}(G), \mathcal{U}(S), l \circ \varepsilon_S, r \circ \varepsilon_S)$ is an occurrence net with symmetry. \square*

With the symmetry on $\mathcal{U}(G)$ at our disposal, we obtain the equivalence relation \sim on morphisms from any occurrence net to $\mathcal{U}(G)$. This is used to extend Theorem 1 to obtain cofreeness ‘up to symmetry’.

Theorem 2 *Let G be a general Petri net and O be an occurrence net. For any morphism $(\pi, \gamma) : O \rightarrow G$ in **Gen**, there is a morphism $(\theta, \alpha) : O \rightarrow \mathcal{U}(G)$ in **Gen** such that*

$$\begin{array}{ccc} \mathcal{U}(G) & \xrightarrow{\varepsilon_G} & G \\ (\theta, \alpha) \uparrow & \nearrow & (\pi, \gamma) \\ O & & \end{array}$$

*commutes, i.e. $\varepsilon_G \circ (\theta, \alpha) = (\pi, \gamma)$. Furthermore, any morphism $(\theta', \alpha') : O \rightarrow \mathcal{U}(G)$ in **Gen** such that $\varepsilon_G \circ (\theta', \alpha') = (\pi, \gamma)$ satisfies $(\theta, \alpha) \sim (\theta', \alpha')$ with respect to the symmetry on $\mathcal{U}(G)$ described above. \square*

5 A coreflection up to symmetry

We show how the results of the last section are part of a more general coreflection from occurrence nets with symmetry to general nets with symmetry. In the last section, we showed how to unfold a general net to an occurrence net *with symmetry*. For the coreflection, we need to extend this construction to unfold general nets themselves with symmetry.

To show that the ‘inclusion’ $I : \mathbf{SOcc} \rightarrow \mathbf{SGen}$ taking an occurrence net with symmetry (O, S, l, r) to a general net with symmetry is a functor, it is necessary to show that the transitivity property holds of the symmetry in **SGen**. For this it is important that pullbacks are not disturbed in moving from **Occ_f** to the larger category **Gen_f**, as is assured by Lemma 1.

We now have a functor $I : \mathbf{SOcc} \rightarrow \mathbf{SGen}$, respecting \sim , regarding an occurrence net with symmetry (O, S, l, r) itself directly as a general net with symmetry.

It remains for us to define the unfolding operation on objects of the category of general nets with symmetry. Its extension to a *pseudo* functor will follow from the biadjunction. Let (G, S_G, l, r) be a general net with symmetry. Let $\varepsilon_G : \mathcal{U}(G) \rightarrow G$ be the folding morphism given earlier in Proposition 2. It is open by Proposition 4. The general net (G, S_G, l, r) is ‘unfolded’ to the occurrence net with symmetry $\mathcal{U}(G, S_G, l, r) = (\mathcal{U}(G), S_0, l_0, r_0)$; its symmetry, $S_0 \triangleq \mathcal{U}(S')$, $l_0 \triangleq l' \circ \varepsilon_{S'}$ and $r_0 \triangleq r' \circ \varepsilon_{S'}$, is given by unfolding the inverse image of the symmetry on G along the open morphism $\varepsilon_G : \mathcal{U}(G) \rightarrow G$:

$$\begin{array}{ccccc} & & \mathcal{U}(S') & & \\ & & \downarrow \varepsilon_{S'} & & \\ & & S' & & \\ & \swarrow l' & \downarrow \sphericalangle & \searrow r' & \\ \mathcal{U}(G) & \xrightarrow{\quad} & \mathcal{U}(G) & \xrightarrow{\quad} & \mathcal{U}(G) \\ & \swarrow \varepsilon_G & \downarrow \sphericalangle & \searrow \varepsilon_G & \\ & G & \downarrow \sphericalangle & G & \\ & \swarrow l & \downarrow \sphericalangle & \searrow r & \\ & G & & G & \end{array}$$

The pullbacks are in \mathbf{Gen}_f . This diagram makes clear that ε_G is a morphism preserving symmetry.

Now that we have the inclusion $I : \mathbf{SGen} \rightarrow \mathbf{SOcc}$ and the operation of unfolding a general net with symmetry, we are able to generalize Theorem 1 to give a cofreeness result:

Theorem 3 *Let $\widehat{G} = (G, S_G, l_G, r_G)$ be a general net with symmetry and $\widehat{O} = (O, S_O, l_O, r_O)$ be an occurrence net with symmetry. For any $(\pi, \gamma) : \widehat{O} \rightarrow \widehat{G}$ in \mathbf{SGen} , there is a morphism $(\theta, \alpha) : \widehat{O} \rightarrow \mathcal{U}(\widehat{G})$ in \mathbf{SGen} such that the following diagram commutes:*

$$\begin{array}{ccc} \mathcal{U}(\widehat{G}) & \xrightarrow{\varepsilon_{\widehat{G}}} & \widehat{G} \\ (\theta, \alpha) \uparrow & \nearrow (\pi, \gamma) & \\ \widehat{O} & & \end{array}$$

Furthermore, (θ, α) is unique up to symmetry: any $(\theta', \alpha') : \widehat{O} \rightarrow \mathcal{U}(\widehat{G})$ such that $\varepsilon_{\widehat{G}} \circ (\theta', \alpha') \sim (\pi, \gamma)$ satisfies $(\theta, \alpha) \sim (\theta', \alpha')$. \square

Technically, we have a biadjunction from \mathbf{SOcc} to \mathbf{SGen} with I left biadjoint to \mathcal{U} (which extends to a pseudo functor). Its counit is ε and its unit is a natural isomorphism $\widehat{O} \cong \mathcal{U}(\widehat{O})$. In this sense, we have established a coreflection from \mathbf{SOcc} to \mathbf{SGen} up to symmetry.

6 Related work

Occurrence nets were first introduced in [8] together with the operation of unfolding singly-marked safe nets. The coreflection between occurrence nets and safe nets was first shown in [11]. A number of attempts have been made since then to characterize the unfoldings of more general forms of net.

Engelfriet defines the unfolding of (singly-marked) P/T nets in [2]. Rather than giving a coreflection between the categories, the unfolding is characterized as the greatest element of a complete lattice of occurrence nets embedding into the P/T net.

A coreflection between a subcategory of (singly-marked) general nets and a category of embellished forms of transition system is given in [7]. There, the restriction to particular kinds of net morphism is of critical importance; taking the more general morphisms of general Petri nets presented here would have resulted in the cofreeness property failing for an analogous reason to the failure of cofreeness of the unfolding of general nets to occurrence nets without symmetry.

An adjunction between a subcategory of singly-marked general nets and the category of occurrence nets is given in [6]. The restriction imposed on the morphisms of general nets there, however, precludes in general there being a morphism from $\mathcal{U}(G)$ to G in their category of general nets if $\mathcal{U}(G)$, the occurrence net unfolding of G , is regarded directly as a general net. To obtain an adjunction, the functor from the category of occurrence nets into the category of general nets is not regarded as the direct inclusion, but instead occurs through a rather detailed construction and does not yield a coreflection apart from when restricted to the subcategory of semi-weighted nets.

7 Conclusion

In this paper, we have shown that there is an implicit symmetry on the unfolding of a general net arising from multiplicities in its initial marking and multiplicities on arcs from its transitions. By placing this symmetry on the unfolding, extending the scheme in [14], we are able to obtain a cofreeness up to symmetry result, thus characterizing the unfolding up to the symmetry. We

then adjoin symmetry to the categories of general nets and occurrence nets (using the standard definition of net morphism) to obtain a coreflection up to symmetry.

It is becoming clear from this and other work [10] that sometimes, in adjoining symmetry, models do not fit the simple scheme outlined in [14] appropriate to event structures and stable families. For example, the category of general nets with *all* morphisms does not have pullbacks as is required for the scheme in [14]. Alongside [10], the consideration of how symmetry may be placed on nets here and in [4] has allowed us to progress to allow more liberal axioms on categories of models which enable their extension with symmetry.

The generalization of nets presented here to allow them to have more than one initial marking is also necessary for equipping other, less general, forms of net, such as safe nets or occurrence nets, with symmetry. In the companion paper [4], we extend the existing coreflection between occurrence nets and P/T nets to this setting and show that this yields a coreflection between occurrence nets with symmetry and P/T nets with symmetry, taking causal nets to be paths. In [4], we also show that a coreflection can be obtained between event structures and multiply-marked occurrence nets (when restricting to synchronous morphisms) and show that this yields a coreflection between occurrence nets with symmetry and event structures with symmetry, with respect to elementary event structures as paths.

References

- [1] A. Carboni and E. M. Vitale. Regular and exact completions. *Journal of Pure and Applied Algebra*, 125(1–3):79–116, March 1998.
- [2] J. Engelfriet. Branching processes of Petri nets. *Acta Informatica*, 28:575–591, 1991.
- [3] E. Fabre. On the construction of pullbacks for safe Petri nets. In *Proc. ICATPN '06*, volume 4024 of *Lecture Notes in Computer Science*, 2006.
- [4] J. Hayman and G. Winskel. Symmetry in Petri nets. Submitted. Available from www.cl.cam.ac.uk/users/jmh93/.
- [5] A. Joyal, M. Nielsen, and G. Winskel. Bisimulation from open maps. In *Proc. LICS '93*, volume 127(2) of *Information and Computation*, 1995.
- [6] J. Meseguer, U. Montanari, and V. Sassone. On the semantics of Place/Transition Petri nets. *Mathematical Structures in Computer Science*, 7:359–397, 1996.
- [7] M. Mukund. Petri nets and step transition systems. *International Journal of Foundations of Computer Science*, 3(4):443–478, 1992.
- [8] M. Nielsen, G. Plotkin, and G. Winskel. Petri nets, event structures and domains, Part 1. *Theoretical Computer Science*, 13:85–108, 1981.
- [9] W. Reisig. *Petri Nets*. EATCS Monographs on Theoretical Computer Science. Springer-Verlag, 1985.
- [10] G. Winskel. The symmetry of stability. Forthcoming.
- [11] G. Winskel. A new definition of morphism on Petri nets. In *Proc. STACS '84*, volume 166 of *Lecture Notes in Computer Science*, 1984.
- [12] G. Winskel. Event structures. In *Advances in Petri Nets, Part II*, volume 255 of *Lecture Notes in Computer Science*. 1986.
- [13] G. Winskel. Petri nets, algebras, morphisms and compositionality. *Information and Computation*, 72(3):197–238, 1987.
- [14] G. Winskel. Event structures with symmetry. *Electronic Notes in Theoretical Computer Science*, 172, 2007.
- [15] G. Winskel. Symmetry and concurrency. In *Proc. CALCO '07*, May 2007. Invited talk.
- [16] G. Winskel and M. Nielsen. Models for concurrency. In *Handbook of Logic and the Foundations of Computer Science*, volume 4, pages 1–148. Oxford University Press, 1995. BRICS report series RS-94-12.

A Multisets

Let the set of natural numbers $\{0, 1, 2, \dots\}$ be denoted \mathbb{N} . A multiset over a set A is a vector of elements of \mathbb{N} indexed by elements of A . For instance, let $A = \{a_0, a_1\}$ and suppose that the multiset X contains two occurrences of a_0 and one of a_1 ; the corresponding multiset is:

$$\begin{matrix} a_0 & \left[\begin{array}{c} 2 \\ 1 \end{array} \right] \\ a_1 & \end{matrix}$$

Let the set of multisets over a set A be denoted $\mu(A)$ and write $X \subseteq_{\mu} A$ if X is a multiset over A . Let $X[a]$ denote the value of the vector at a . Write $\vec{0}_A$ for the empty multiset with basis A . Denote multiplication of the multiset X by a scalar $n \in \mathbb{N}$ by $n \cdot X$. A multiset X with basis A is said to be *finite* if $\sum_{a \in A} X[a]$ is finite.

Define the set $\mathbb{N}_{\infty} = \mathbb{N} \cup \{\infty\}$. An ∞ -multiset over the set A is a vector of elements of \mathbb{N}_{∞} indexed by elements of A . The set of all ∞ -multisets over A is denoted $\mu_{\infty}(A)$, and we write $X \subseteq_{\mu_{\infty}} A$ if X is an ∞ -multiset over A . Addition and multiplication on integers is extended to the element ∞ by defining

$$\begin{aligned} \infty + n &= n + \infty = \infty & (\forall n \in \mathbb{N}_{\infty}) \\ \infty \cdot n &= n \cdot \infty = \infty & (\forall n \in \mathbb{N}_{\infty} \setminus \{0\}) \\ \infty \cdot 0 &= 0 \cdot \infty = 0 \end{aligned}$$

Subtraction $m - n$ of two elements $m, n \in \mathbb{N}_{\infty}$ is a partial operation, defined iff $n \leq m$ and $n \neq \infty$. The result of $\infty - \infty$ is undefined.

Addition and subtraction of multisets are defined in the usual way as addition and subtraction of vectors. On ∞ -multirelations, vector addition and subtraction is defined with respect to the arithmetic above.

A multirelation R between sets A and B is a matrix of elements of \mathbb{N} , and similarly an ∞ -multirelation is a matrix of elements in \mathbb{N}_{∞} . The number of times that the element a is related to b is given by $R[a, b]$, which is the natural number (or ∞) occurring in the a -indexed row and b -indexed column of R . We write $R \subseteq_{\mu} A \times B$ if R is a multirelation between A and B and $R \subseteq_{\mu_{\infty}} A \times B$ if R is an ∞ -multirelation between A and B , noting the equivalent formulation of a multirelation as a multiset over the basis $A \times B$.

Application of a multirelation $R \subseteq_{\mu} A \times B$ to a multiset $X \subseteq_{\mu} A$ is obtained as their inner product $R \cdot X$. In particular, $R \cdot X \subseteq_{\mu} B$ and for any $b \in B$

$$(R \cdot X)[b] = \sum_{a \in A} R[a, b] \cdot X[a].$$

Care has to be taken since $R \subseteq_{\mu} A \times B$ may fail to yield a multiset if the above sum is ∞ at any $b \in B$; an ∞ -multiset would be obtained. Application of an ∞ -multirelation to an ∞ -multiset is always defined, yielding an ∞ -multiset.

A.1 Sets, relations and (partial) functions

We say that a multiset $X \subseteq_{\mu} A$ is a *set* if $X[a] \leq 1$ for all $a \in A$. All the usual notation for sets is adopted in this situation, for example $a \in X$ for $X[a] = 1$. We write $f : X \rightarrow Y$ if f is a function from X to Y .

A *relation* R on sets A and B , written $R \subseteq A \times B$ is identified with a multirelation $R \subseteq_{\mu} A \times B$ such that $R(a, b) \leq 1$ for all $a \in A$ and $b \in B$. We now write $R(a, b)$ or aRb if, as a multirelation, $R[a, b] = 1$. We write R^* for the reflexive, transitive closure of a relation R , and write R^+ for the irreflexive, transitive closure of R .

If f is a *partial* function from set X to set Y , written $f : X \rightarrow_* Y$, that is undefined on $x \in X$, we write $f(x) = *$. Equality includes undefinedness, so if $f : X \rightarrow_* Y$ and

$f' : X' \rightarrow_* Y$ then $f(x) = f'(x')$ iff either both $f(x) = *$ and $f'(x') = *$ or there exists $y \in Y$ such that both $f(x) = y$ and $f'(x') = y$. As with relations, we identify partial functions with certain multirelations.

B Pullbacks in \mathbf{Gen}_f

Proposition 6 *The category \mathbf{Gen}_f has pullbacks.*

PROOF Let G_0, G_1 and G' be general nets. Denote the places of G' by P' , the places of G_0 by P_0 , etc.. Suppose that there are folding morphisms $f_0 = (\eta_0, \beta_0) : G_0 \rightarrow G'$ and $f_1 = (\eta_1, \beta_1) : G_1 \rightarrow G'$. Define the net Q with places P_Q , transitions T_Q , etc. simultaneously with the definition of folding morphisms $q_0 = (\theta_0, \gamma_0) : Q \rightarrow G_0$ and $q_1 = (\theta_1, \gamma_1) : Q \rightarrow G_1$ as as:

$$P_Q \triangleq \{(p_0, p_1) \mid p_0 \in P_0 \text{ and } p_1 \in P_1 \text{ and } f_0(p_0) = f_1(p_1)\}$$

$$T_Q \triangleq \{(C, t_0, t_1, D) \mid C \subseteq_{\mu} P_Q \text{ and } D \subseteq_{\mu_{\infty}} P_Q \text{ and } \eta_0(t_0) = \eta_1(t_1) \\ \text{and } \gamma_0 \cdot C = \text{Pre}_0 \cdot t_0 \text{ and } \gamma_1 \cdot C = \text{Pre}_1 \cdot t_1 \\ \text{and } \gamma_0 \cdot D = \text{Post}_0 \cdot t_0 \text{ and } \gamma_1 \cdot D = \text{Post}_1 \cdot t_1 \}$$

$$\text{Pre}_Q \cdot (C, t_0, t_1, D) \triangleq C \quad \text{Post}_Q \cdot (C, t_0, t_1, D) \triangleq D$$

$$\mathbb{M}_Q = \{M \mid M \subseteq_{\mu_{\infty}} P_Q \text{ and } \gamma_0 \cdot M \in \mathbb{M}_0 \text{ and } \gamma_1 \cdot M \in \mathbb{M}_1\}$$

with the folding morphisms acting on places as

$$\gamma_0(p_0, p_1) \triangleq p_0 \quad \gamma_1(p_0, p_1) \triangleq p_1$$

and on transitions as

$$\theta_0(C, t_0, t_1, D) \triangleq t_0 \quad \theta_1(C, t_0, t_1, D) \triangleq t_1.$$

It can be shown that the net Q is a pullback of f_0 against f_1 in the category \mathbf{Gen}_f , though we omit the proof here. ■

C Pseudo equivalences

Assume a category \mathcal{C} . Let $l, r : S \rightarrow G$ be a pair of morphisms in \mathcal{C} . They form a *pseudo equivalence* (and if jointly monic, an *equivalence*) iff they satisfy:

Reflexivity there is a morphism ρ such that

$$\begin{array}{ccc} & G & \\ \text{id}_G \swarrow & \downarrow \rho & \searrow \text{id}_G \\ G & \leftarrow S \rightarrow & G \end{array}$$

commutes;

Symmetry there is a morphism σ such that

$$\begin{array}{ccc} & S & \\ r \swarrow & \downarrow \sigma & \searrow l \\ G & \leftarrow S \rightarrow & G \end{array}$$

commutes; and

Transitivity there is a weak pullback Q, f, g of r, l and a morphism τ such that

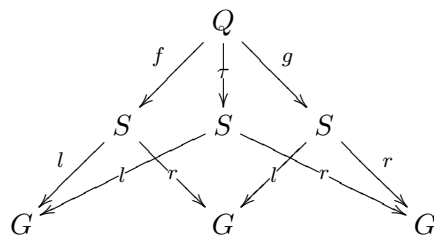

commutes.