

# Randomised Algorithms

Lecture 9: Approximation Algorithms: MAX-3-CNF and Vertex-Cover

Thomas Sauerwald (tms41@cam.ac.uk)

Lent 2024



UNIVERSITY OF  
CAMBRIDGE

Randomised Approximation

MAX-3-CNF

Weighted Vertex Cover

## Approximation Ratio for Randomised Approximation Algorithms

### Approximation Ratio

A **randomised** algorithm for a problem has **approximation ratio**  $\rho(n)$ , if for any input of size  $n$ , the **expected** cost (value)  $\mathbf{E}[C]$  of the returned solution and optimal cost  $C^*$  satisfy:

$$\max \left( \frac{\mathbf{E}[C]}{C^*}, \frac{C^*}{\mathbf{E}[C]} \right) \leq \rho(n).$$

not covered here (non-examinable)

### Randomised Approximation Schemes

An **approximation scheme** is an approximation algorithm, which given any input and  $\epsilon > 0$ , is a  $(1 + \epsilon)$ -approximation algorithm.

- It is a **polynomial-time approximation scheme** (PTAS) if for any fixed  $\epsilon > 0$ , the runtime is polynomial in  $n$ . (For example,  $O(n^{2/\epsilon})$ .)
- It is a **fully polynomial-time approximation scheme** (FPTAS) if the runtime is polynomial in both  $1/\epsilon$  and  $n$ . (For example,  $O((1/\epsilon)^2 \cdot n^3)$ .)

Randomised Approximation

**MAX-3-CNF**

Weighted Vertex Cover

## MAX-3-CNF Satisfiability

Assume that no literal (including its negation) appears more than once in the same clause.

### MAX-3-CNF Satisfiability

- **Given:** 3-CNF formula, e.g.:  $(x_1 \vee x_3 \vee \bar{x}_4) \wedge (x_2 \vee \bar{x}_3 \vee \bar{x}_5) \wedge \dots$
- **Goal:** Find an assignment of the variables that satisfies as many clauses as possible.

Relaxation of the **satisfiability** problem. Want to compute how “close” the formula to being satisfiable is.

Example:

$$(x_1 \vee x_3 \vee \bar{x}_4) \wedge (x_1 \vee \bar{x}_3 \vee \bar{x}_5) \wedge (x_2 \vee \bar{x}_4 \vee x_5) \wedge (\bar{x}_1 \vee x_2 \vee \bar{x}_3)$$

$x_1 = 1, x_2 = 0, x_3 = 1, x_4 = 0$  and  $x_5 = 1$  satisfies 3 (out of 4 clauses)

Idea: What about assigning each variable uniformly and independently at random?

## Analysis

### Theorem 35.6

Given an instance of MAX-3-CNF with  $n$  variables  $x_1, x_2, \dots, x_n$  and  $m$  clauses, the randomised algorithm that sets each variable independently at random is a **randomised  $8/7$ -approximation algorithm**.

Proof:

- For every clause  $i = 1, 2, \dots, m$ , define a **random variable**:

$$Y_i = \mathbf{1}\{\text{clause } i \text{ is satisfied}\}$$

- Since each literal (including its negation) appears at most once in clause  $i$ ,

$$\mathbf{P}[\text{clause } i \text{ is not satisfied}] = \frac{1}{2} \cdot \frac{1}{2} \cdot \frac{1}{2} = \frac{1}{8}$$

$$\Rightarrow \mathbf{P}[\text{clause } i \text{ is satisfied}] = 1 - \frac{1}{8} = \frac{7}{8}$$

$$\Rightarrow \mathbf{E}[Y_i] = \mathbf{P}[Y_i = 1] \cdot 1 = \frac{7}{8}.$$

- Let  $Y := \sum_{i=1}^m Y_i$  be the number of satisfied clauses. Then,

$$\mathbf{E}[Y] = \mathbf{E}\left[\sum_{i=1}^m Y_i\right] = \sum_{i=1}^m \mathbf{E}[Y_i] = \sum_{i=1}^m \frac{7}{8} = \frac{7}{8} \cdot m. \quad \square$$

Linearity of Expectations

maximum number of satisfiable clauses is  $m$

## Interesting Implications

### Theorem 35.6

Given an instance of MAX-3-CNF with  $n$  variables  $x_1, x_2, \dots, x_n$  and  $m$  clauses, the randomised algorithm that sets each variable independently at random is a polynomial-time randomised  $8/7$ -approximation algorithm.

### Corollary

For any instance of MAX-3-CNF, there exists an assignment which satisfies at least  $\frac{7}{8}$  of all clauses.

There is  $\omega \in \Omega$  such that  $Y(\omega) \geq \mathbf{E}[Y]$

**Probabilistic Method:** powerful tool to show existence of a non-obvious property.

### Corollary

Any instance of MAX-3-CNF with at most 7 clauses is satisfiable.

Follows from the previous Corollary.

## Expected Approximation Ratio

### Theorem 35.6

Given an instance of MAX-3-CNF with  $n$  variables  $x_1, x_2, \dots, x_n$  and  $m$  clauses, the randomised algorithm that sets each variable independently at random is a polynomial-time randomised  $8/7$ -approximation algorithm.

One could prove that the probability to satisfy  $(7/8) \cdot m$  clauses is at least  $1/(8m)$

$$\mathbf{E}[Y] = \frac{1}{2} \cdot \mathbf{E}[Y \mid x_1 = 1] + \frac{1}{2} \cdot \mathbf{E}[Y \mid x_1 = 0].$$

$Y$  is defined as in the previous proof.

One of the two conditional expectations is at least  $\mathbf{E}[Y]$

GREEDY-3-CNF( $\phi, n, m$ )

- 1: **for**  $j = 1, 2, \dots, n$
- 2:     Compute  $\mathbf{E}[Y \mid x_1 = v_1, \dots, x_{j-1} = v_{j-1}, x_j = 1]$
- 3:     Compute  $\mathbf{E}[Y \mid x_1 = v_1, \dots, x_{j-1} = v_{j-1}, x_j = 0]$
- 4:     Let  $x_j = v_j$  so that the conditional expectation is maximised
- 5: **return** the assignment  $v_1, v_2, \dots, v_n$



## Run of GREEDY-3-CNF( $\varphi, n, m$ )

$$(x_1 \vee x_2 \vee x_3) \wedge (x_1 \vee \bar{x}_2 \vee \bar{x}_4) \wedge (x_1 \vee x_2 \vee \bar{x}_4) \wedge (\bar{x}_1 \vee \bar{x}_3 \vee x_4) \wedge (x_1 \vee x_2 \vee \bar{x}_4) \wedge (\bar{x}_1 \vee \bar{x}_2 \vee \bar{x}_3) \wedge (\bar{x}_1 \vee x_2 \vee x_3) \wedge (\bar{x}_1 \vee \bar{x}_2 \vee x_3) \wedge (x_1 \vee x_3 \vee x_4) \wedge (x_2 \vee \bar{x}_3 \vee \bar{x}_4)$$

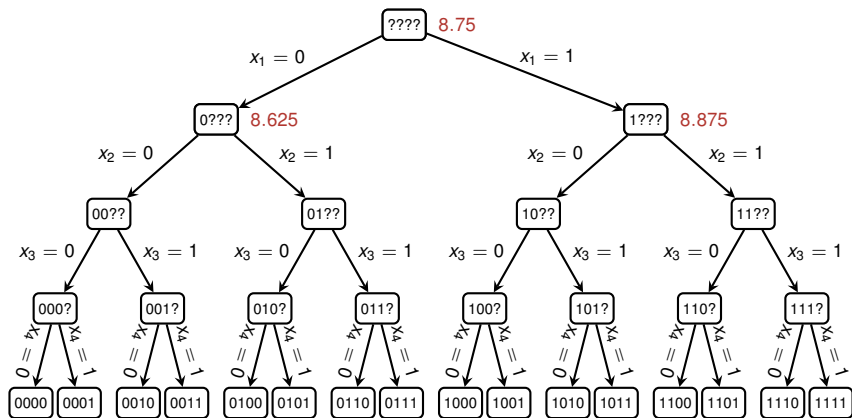

# Run of GREEDY-3-CNF( $\varphi, n, m$ )

$$1 \wedge 1 \wedge 1 \wedge (\overline{x_3} \vee x_4) \wedge 1 \wedge (\overline{x_2} \vee \overline{x_3}) \wedge (x_2 \vee x_3) \wedge (\overline{x_2} \vee x_3) \wedge 1 \wedge (x_2 \vee \overline{x_3} \vee \overline{x_4})$$

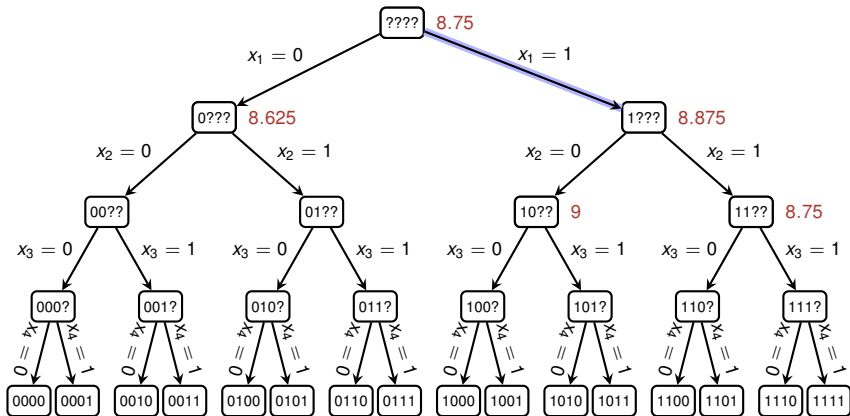

# Run of GREEDY-3-CNF( $\varphi, n, m$ )

$$1 \wedge 1 \wedge 1 \wedge (\overline{x_3} \vee x_4) \wedge 1 \wedge 1 \wedge (x_3) \wedge 1 \wedge 1 \wedge (\overline{x_3} \vee \overline{x_4})$$

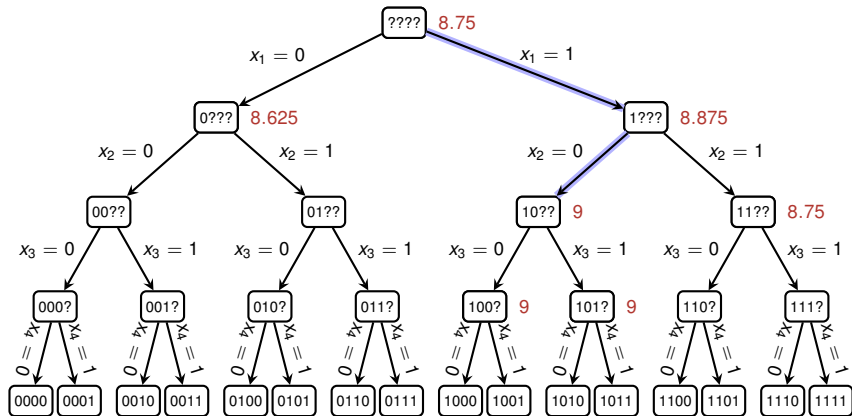

# Run of GREEDY-3-CNF( $\varphi, n, m$ )

$1 \wedge 1 \wedge 1 \wedge 1 \wedge 1 \wedge 1 \wedge 0 \wedge 1 \wedge 1 \wedge 1$

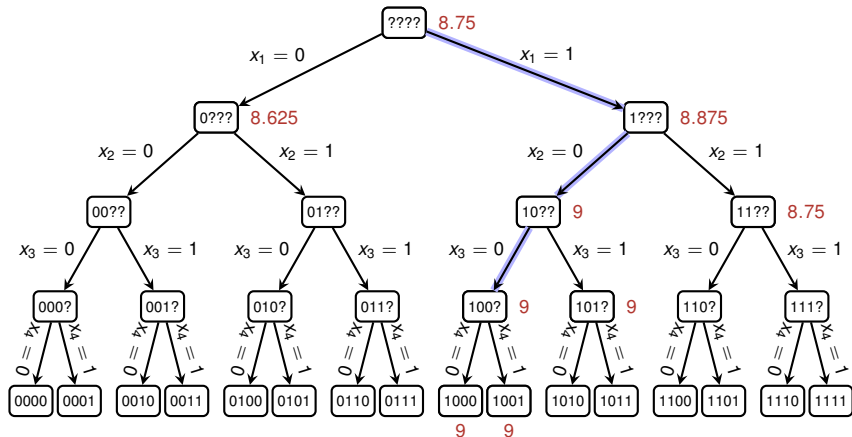

# Run of GREEDY-3-CNF( $\varphi, n, m$ )

$1 \wedge 1 \wedge 1 \wedge 1 \wedge 1 \wedge 1 \wedge 0 \wedge 1 \wedge 1 \wedge 1$

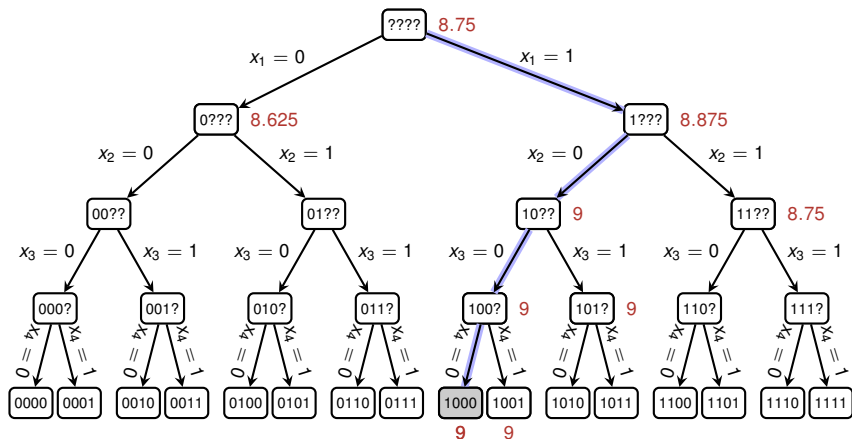



This algorithm is deterministic.

**Theorem**

GREEDY-3-CNF( $\phi, n, m$ ) is a polynomial-time  $8/7$ -approximation.

Proof:

- **Step 1:** polynomial-time algorithm
  - In iteration  $j = 1, 2, \dots, n$ ,  $Y = Y(\phi)$  averages over  $2^{n-j+1}$  assignments
  - A smarter way is to use **linearity of (conditional) expectations**:

$$\mathbf{E} [ Y \mid x_1 = v_1, \dots, x_{j-1} = v_{j-1}, x_j = 1 ] = \sum_{i=1}^m \mathbf{E} [ Y_i \mid x_1 = v_1, \dots, x_{j-1} = v_{j-1}, x_j = 1 ]$$

- **Step 2:** satisfies at least  $7/8 \cdot m$  clauses

computable in  $O(1)$

- Due to the greedy choice in each iteration  $j = 1, 2, \dots, n$ ,

$$\begin{aligned} \mathbf{E} [ Y \mid x_1 = v_1, \dots, x_{j-1} = v_{j-1}, x_j = v_j ] &\geq \mathbf{E} [ Y \mid x_1 = v_1, \dots, x_{j-1} = v_{j-1} ] \\ &\geq \mathbf{E} [ Y \mid x_1 = v_1, \dots, x_{j-2} = v_{j-2} ] \end{aligned}$$

$\vdots$

$$\geq \mathbf{E} [ Y ] = \frac{7}{8} \cdot m. \quad \square$$

## MAX-3-CNF: Concluding Remarks

---

— Theorem 35.6 —

Given an instance of MAX-3-CNF with  $n$  variables  $x_1, x_2, \dots, x_n$  and  $m$  clauses, the randomised algorithm that sets each variable independently at random is a **randomised  $8/7$ -approximation algorithm**.

— Theorem —

**GREEDY-3-CNF**( $\phi, n, m$ ) is a polynomial-time  $8/7$ -approximation.

— Theorem (Hastad'97) —

For any  $\epsilon > 0$ , there is **no** polynomial time  $8/7 - \epsilon$  **approximation algorithm** of MAX3-CNF unless  $P=NP$ .

Essentially there is nothing smarter than just guessing!



Yes, my research has finally concluded...

So you said you have been studying the field of algorithms for MAX-3-SAT?

...the best approach is to **randomly guess** a solution.

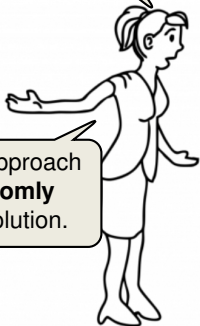

Source of Image: Stefan Szeider, TU Vienna

# Outline

---

Randomised Approximation

MAX-3-CNF

Weighted Vertex Cover

## The Weighted Vertex-Cover Problem

### Vertex Cover Problem

- **Given:** Undirected, **vertex-weighted** graph  $G = (V, E)$
- **Goal:** Find a **minimum-weight** subset  $V' \subseteq V$  such that if  $\{u, v\} \in E(G)$ , then  $u \in V'$  or  $v \in V'$ .

This is (still) an NP-hard problem.



**Question:** How can we deal with graphs that have **negative** weights?

### Applications:

- Every **edge** forms a **task**, and every **vertex** represents a **person/machine** which can execute that task
- **Weight** of a vertex could be **salary** of a person
- Perform all tasks with the **minimal amount of resources**

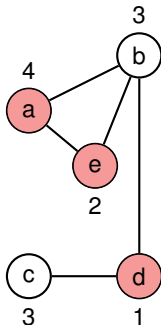

## A Greedy Approach working for Unweighted Vertex Cover

---

APPROX-VERTEX-COVER( $G$ )

```
1  $C = \emptyset$ 
2  $E' = G.E$ 
3 while  $E' \neq \emptyset$ 
4     let  $(u, v)$  be an arbitrary edge of  $E'$ 
5      $C = C \cup \{u, v\}$ 
6     remove from  $E'$  every edge incident on either  $u$  or  $v$ 
7 return  $C$ 
```

This algorithm is a 2-approximation for **unweighted graphs!**

## A Greedy Approach working for Unweighted Vertex Cover

APPROX-VERTEX-COVER( $G$ )

- 1  $C = \emptyset$
- 2  $E' = G.E$
- 3 **while**  $E' \neq \emptyset$
- 4     let  $(u, v)$  be an arbitrary edge of  $E'$
- 5      $C = C \cup \{u, v\}$
- 6     remove from  $E'$  every edge incident on either  $u$  or  $v$
- 7 **return**  $C$

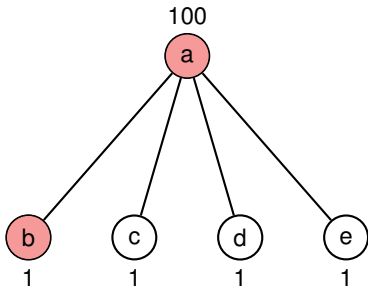

Computed solution has weight 101

## A Greedy Approach working for Unweighted Vertex Cover

APPROX-VERTEX-COVER( $G$ )

- 1  $C = \emptyset$
- 2  $E' = G.E$
- 3 **while**  $E' \neq \emptyset$
- 4     let  $(u, v)$  be an arbitrary edge of  $E'$
- 5      $C = C \cup \{u, v\}$
- 6     remove from  $E'$  every edge incident on either  $u$  or  $v$
- 7 **return**  $C$

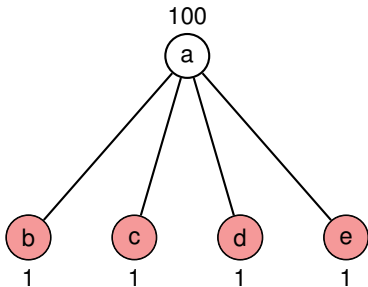

Optimal solution has weight 4

## Invoking an (Integer) Linear Program

Idea: Round the solution of an associated linear program.

0-1 Integer Program

$$\begin{array}{ll} \text{minimize} & \sum_{v \in V} w(v)x(v) \\ \text{subject to} & x(u) + x(v) \geq 1 \quad \text{for each } (u, v) \in E \\ & x(v) \in \{0, 1\} \quad \text{for each } v \in V \end{array}$$

optimum is a lower bound on the optimal weight of a minimum weight-cover.

Linear Program

$$\begin{array}{ll} \text{minimize} & \sum_{v \in V} w(v)x(v) \\ \text{subject to} & x(u) + x(v) \geq 1 \quad \text{for each } (u, v) \in E \\ & x(v) \in [0, 1] \quad \text{for each } v \in V \end{array}$$

**Rounding Rule:** if  $x(v) \geq 1/2$  then round up, otherwise round down.

# The Algorithm

---

APPROX-MIN-WEIGHT-VC( $G, w$ )

```
1  $C = \emptyset$ 
2 compute  $\bar{x}$ , an optimal solution to the linear program
3 for each  $v \in V$ 
4     if  $\bar{x}(v) \geq 1/2$ 
5          $C = C \cup \{v\}$ 
6 return  $C$ 
```

## Theorem 35.7

APPROX-MIN-WEIGHT-VC is a polynomial-time 2-approximation algorithm for the minimum-weight vertex-cover problem.

is polynomial-time because we can solve the linear program in polynomial time



## Example of APPROX-MIN-WEIGHT-VC

$$\bar{x}(a) = \bar{x}(b) = \bar{x}(e) = \frac{1}{2}, \bar{x}(d) = 1, \bar{x}(c) = 0$$

$$x(a) = x(b) = x(e) = 1, x(d) = 1, x(c) = 0$$

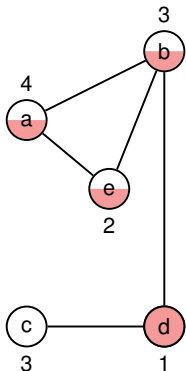

Rounding

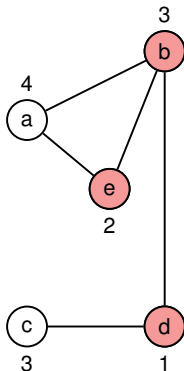
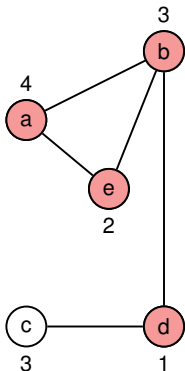

fractional solution of LP  
with weight = 5.5

rounded solution of LP  
with weight = 10

optimal solution  
with weight = 6

## Approximation Ratio

Proof (Approximation Ratio is 2 and Correctness):

- Let  $C^*$  be an optimal solution to the minimum-weight vertex cover problem
- Let  $z^*$  be the value of an optimal solution to the linear program, so

$$z^* \leq w(C^*)$$

- Step 1:** The computed set  $C$  covers all vertices:
  - Consider any edge  $(u, v) \in E$  which imposes the constraint  $x(u) + x(v) \geq 1$   
 $\Rightarrow$  at least one of  $\bar{x}(u)$  and  $\bar{x}(v)$  is at least  $1/2 \Rightarrow C$  covers edge  $(u, v)$
- Step 2:** The computed set  $C$  satisfies  $w(C) \leq 2z^*$ :

$$w(C^*) \geq z^* = \sum_{v \in V} w(v)\bar{x}(v) \geq \sum_{v \in V: \bar{x}(v) \geq 1/2} w(v) \cdot \frac{1}{2} = \frac{1}{2}w(C). \quad \square$$

