

Mobile and Sensor Systems

Lecture 4: Sensor Network Routing
Prof Cecilia Mascolo

In this lecture

- We will introduce sensor network routing protocols, in particular:
 - Directed diffusion
 - MINT routing

Network Protocols

- Can we apply ad hoc networks protocols?
- Yes protocols like epidemic can be applied but overhead is an issue.
- Aims are usually different: not communication but data reporting to single or multiple source.
- Specific protocols have been devised.
- Specific nodes are interested in specific events:
 - Sink interested in all results;
 - Sink interested in a sensor reading change.

Protocols for Repeated interactions

- Subscribe once, events happen multiple times:
 - Exploring the network topology might actually pay off. But: unknown which node can provide data, multiple nodes might ask for data.
 - How to map this onto a “routing” problem?
- Put enough information into the network: publications and subscriptions can be mapped onto each other. But try to avoid using unique identifiers: might not be available, might require too big a state size in intermediate nodes.

Directed Diffusion

- *Directed diffusion* as one option for implementation:
 - Try to rely only on *local interactions*.
 - Data-centric approach.
- Nodes send “interests” for data which are diffused in the network.
- Sensors produce data which is routed according to interests.
- Intermediate nodes can filter/aggregate data.

Directed Diffusion

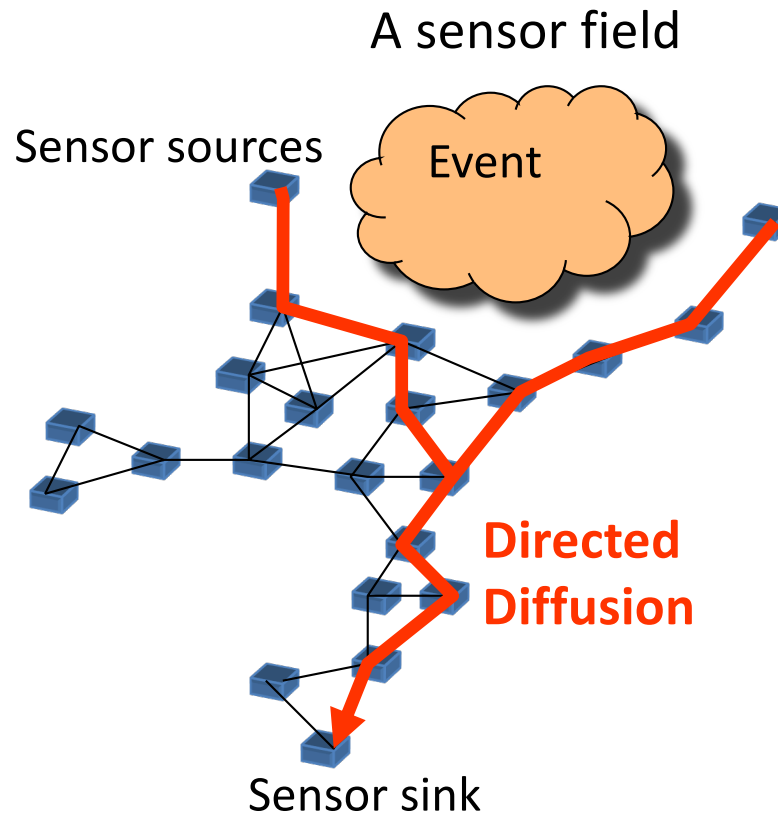

Interest Propagation

- Each sink sends expression of interests to neighbours.
- Each node will store interests and disseminate those further to their neighbours.
 - Cache of interest is checked not to repeat disseminations.
- Interests need refreshing from the sink (they time out).
- Interests have a “rate of events” which is defined as “**gradient**”.

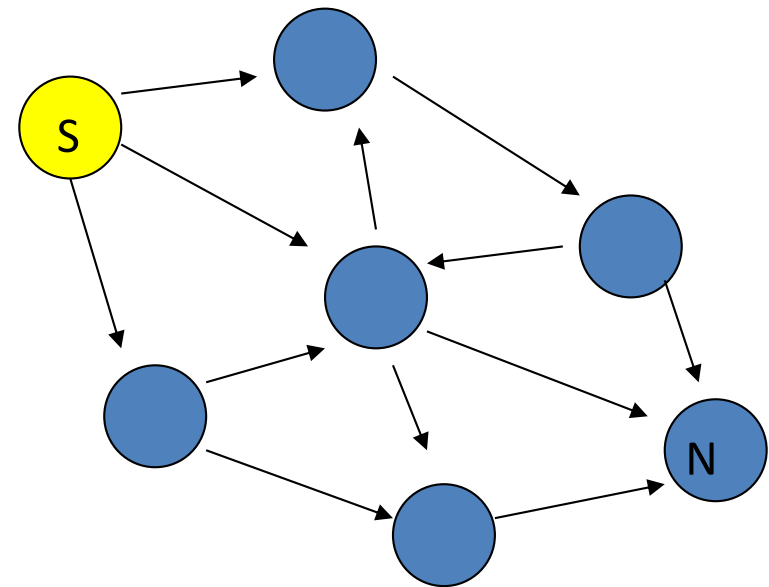

Interest Example

```
Type = Wheeled vehicle // detect vehicle location  
Interval = 20 ms      // send events every 20ms  
Duration = 10 s      // Send for next 10 s  
Field = [x1, y1, x2, y2] // from sensors in this area
```

Data delivery

- Sensor data sources emit events which are sent to neighbours according to interest (ie if there is a gradient).
- Each intermediate node sends back data at a rate which depends on the gradient.
 - ie if gradient is 1 event per second and 2 events per second are received send either the first or a combination of the two (aggregation).

Gradients Reinforcement

- Events are stored to avoid cycles (check if same event received before).
- Data can reach a node through different paths. *Gradient reinforcement needed.*
- When gradients are established the rate is defined provisionally (usually low). Sinks will ‘reinforce’ good paths which will be followed with higher rate.
- A path expires after a timeout so if not reinforced it will cease to exist. This allows adaptation to changes and failures.

Directed diffusion – Two-phase pull

- Phase 1: nodes distribute *interests* in certain kinds of named data:
 - Specified as attribute-value pairs
- Interests are flooded in the network.
 - Apparently obvious solution: remember from where interests came, set up a “tree”.
 - Problem: Node X cannot distinguish, in absence of unique identifiers, between the two situations on the right – set up only one or three trees?

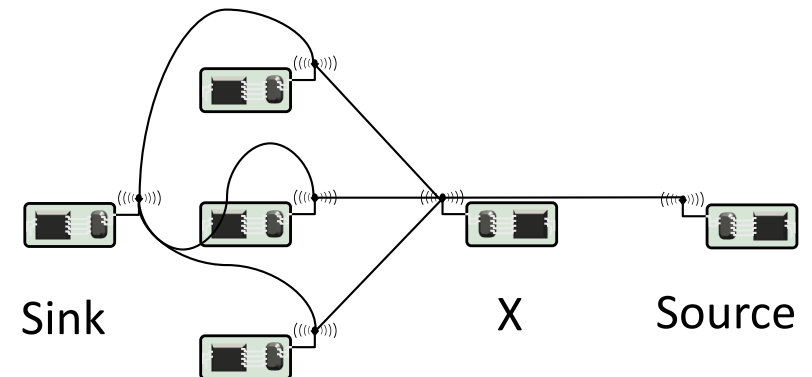
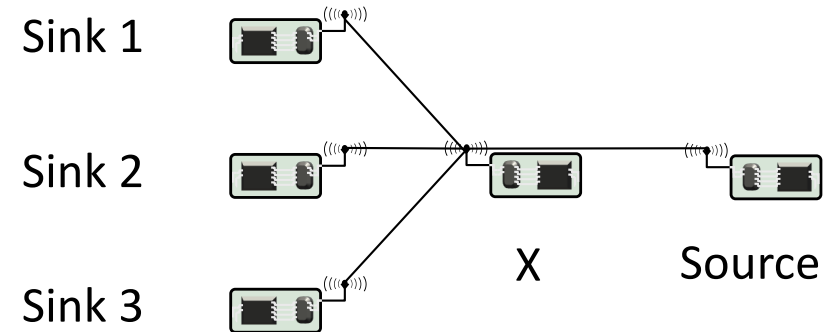

Direction diffusion

Gradients in two-phase pull

- Option 1: Node X forwarding received data to all “parents” in a “tree”: Not attractive, many needless packet repetitions over multiple routes.
- Option 2: node X only forwards to one parent. Not acceptable, data sinks might miss events.
- Option 3: Only provisionally send data to all parents, but ask data sinks to help in selecting which paths are redundant, which are needed.
 - Information from where an interest came is called *gradient*.
 - Forward all published data along all existing gradients

Direction diffusion

Gradients in two-phase pull

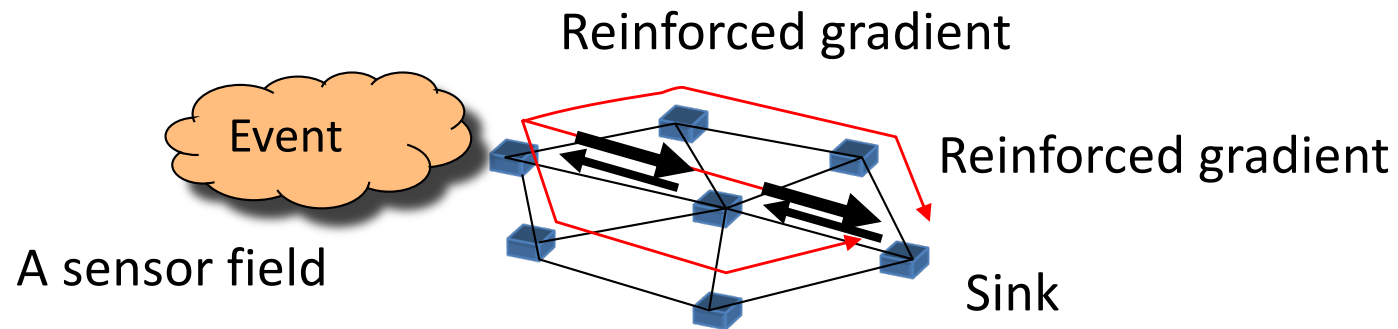

Directed diffusion – extensions

- Problem: Interests are flooded through the network.
- Geographic scoping & directed diffusion: Interest in data from specific areas should be sent to sources in specific geo locations only.
- Push diffusion – few senders, many receivers: Same interface/naming concept, but different routing protocol. Here: do not flood interests, but flood the (relatively few) data. Interested nodes will start reinforcing the gradients.

Issues

- Purely theoretical work.
- Apart from the flooding of the interests...No consideration of real world issues such as link stability or link load and load dependence.
- Mac Layer issues (assume nodes are awake...or does not discuss it).
- More recent approaches have considered link capabilities more explicitly as part of the routing decision making.

Data aggregation

- Less packets transmitted -> less energy used
- To still transmit data, packets need to combine their data into fewer packets ! *aggregation* is needed
- Depending on network, aggregation can be useful or pointless
- Directed diffusion gradient might require some data aggregation

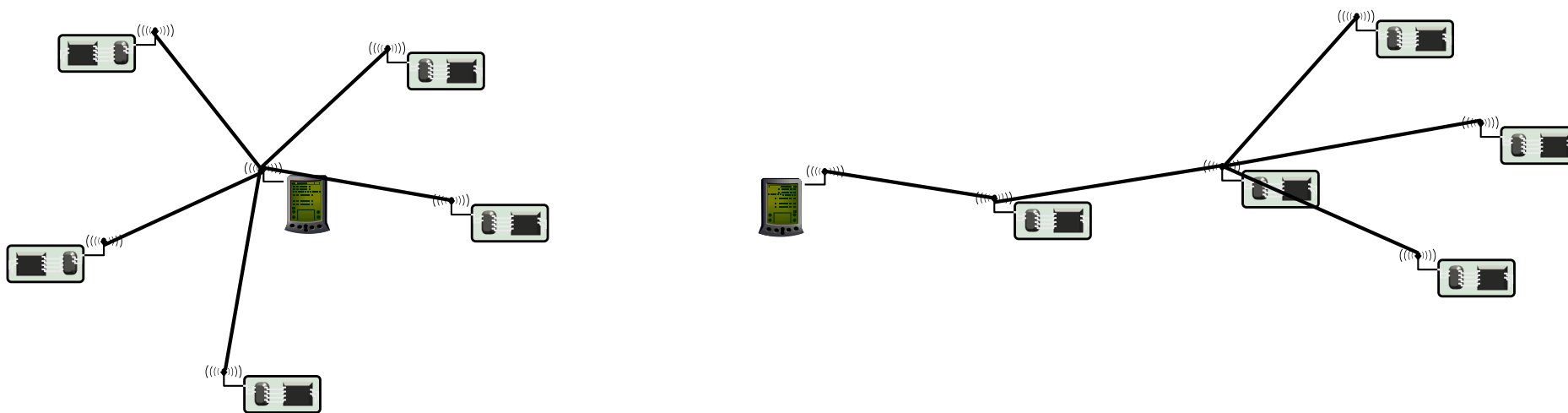

Metrics for data aggregation

- *Accuracy*: Difference between value(s) the sink obtains from aggregated packets and from the actual value (obtained in case no aggregation/no faults occur)
- *Completeness*: Percentage of all readings included in computing the final aggregate at the sink
- *Latency*
- *Message overhead*

Link quality based routing (MT Routing)

- Directed diffusion uses some sort of implicit ways to indicate which are the good links.
 - Through the gradient.
- Ad hoc routing protocols for mobile networks route messages based on shorter path in terms of number of hops.
- The essence of the next protocol we present: “number of hops might not be the best performance indication in wireless sensor network”.

Routing based on Link Estimation

- Routing algorithms should take into account underlying network factors and under realistic loads.
- Link connectivity in reality is not spherical as often assumed.

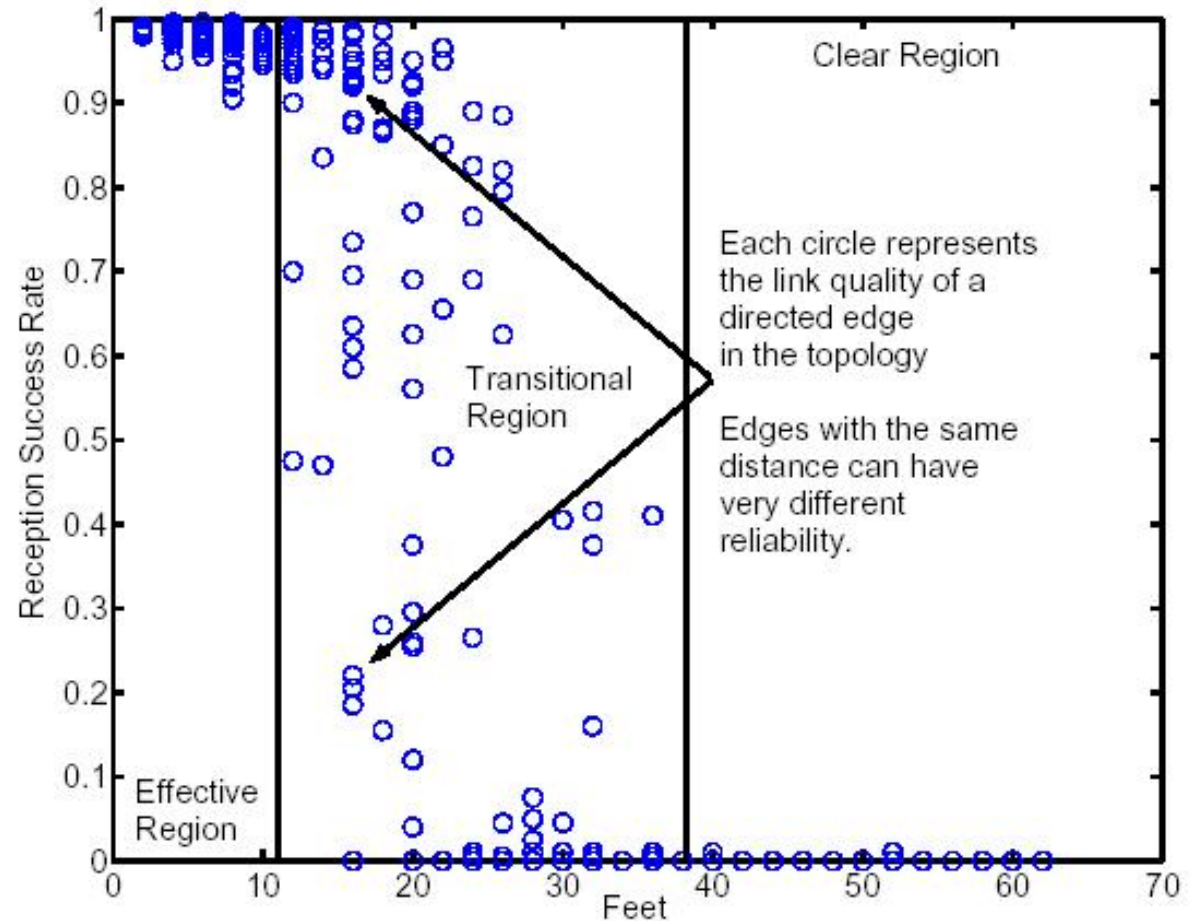

RSSI – Driving

Signal Strength (-dbm) - Top View - Source Node: 1

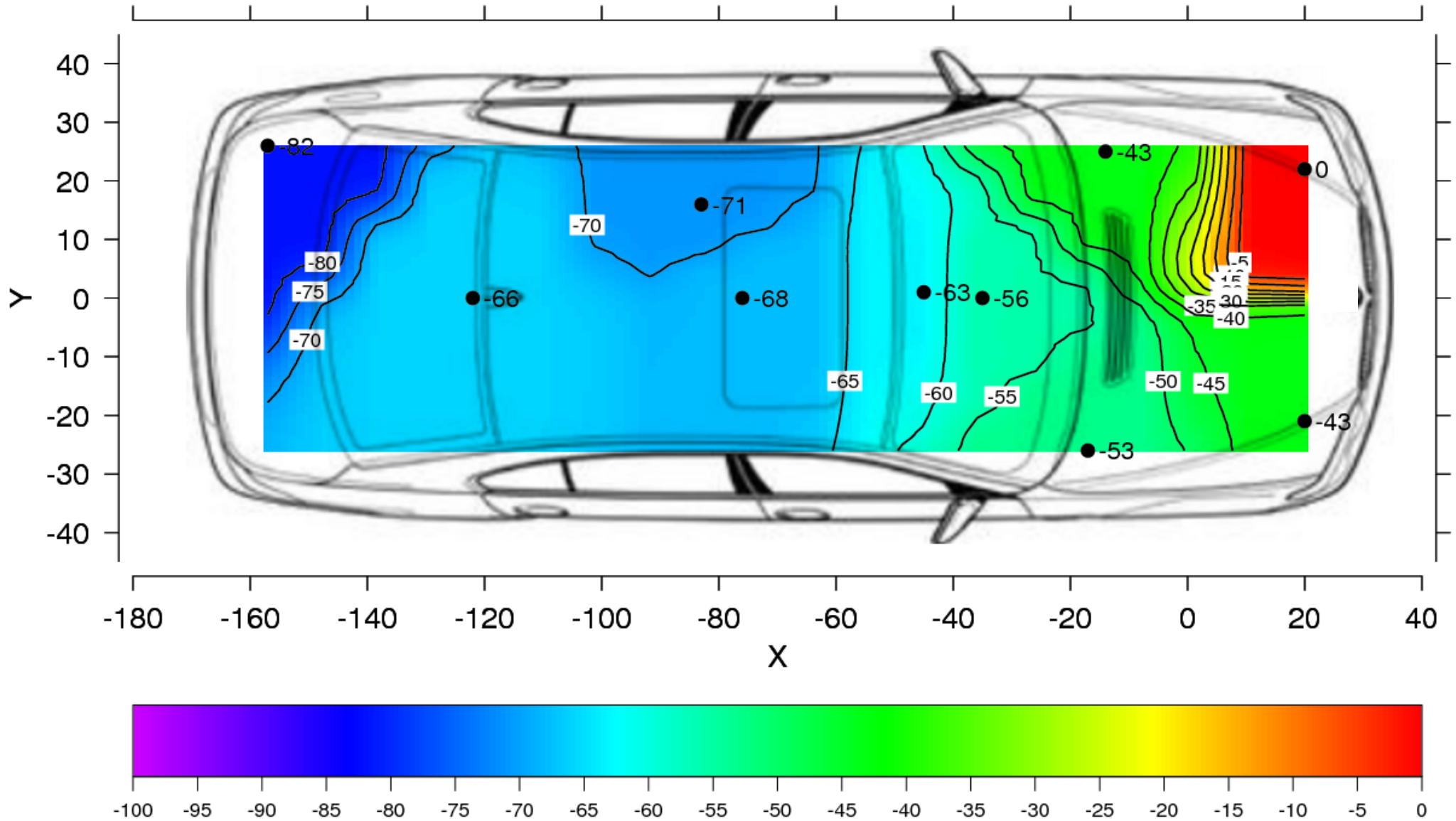

Link Estimation

- A good estimator in this setting must:
 - Be stable.
 - Be simple to compute and have a low memory footprint.
 - React quickly to large changes in quality.
 - Neighbour broadcast can be used to passively estimate.

WMEWMA

- Snooping
 - Track the sequence numbers of the packets from each source to infer losses
- Window mean with EWMA
 - $EWMA(t_x) = a (MA(t_x)) + (1-a)EWMA(t_{(x-1)})$
 - t_x : last time interval; a: weight
 - $MA(t_x)$ is the number of packets received in the last period.

WMEWMA ($t = 30, a = 0.6$)

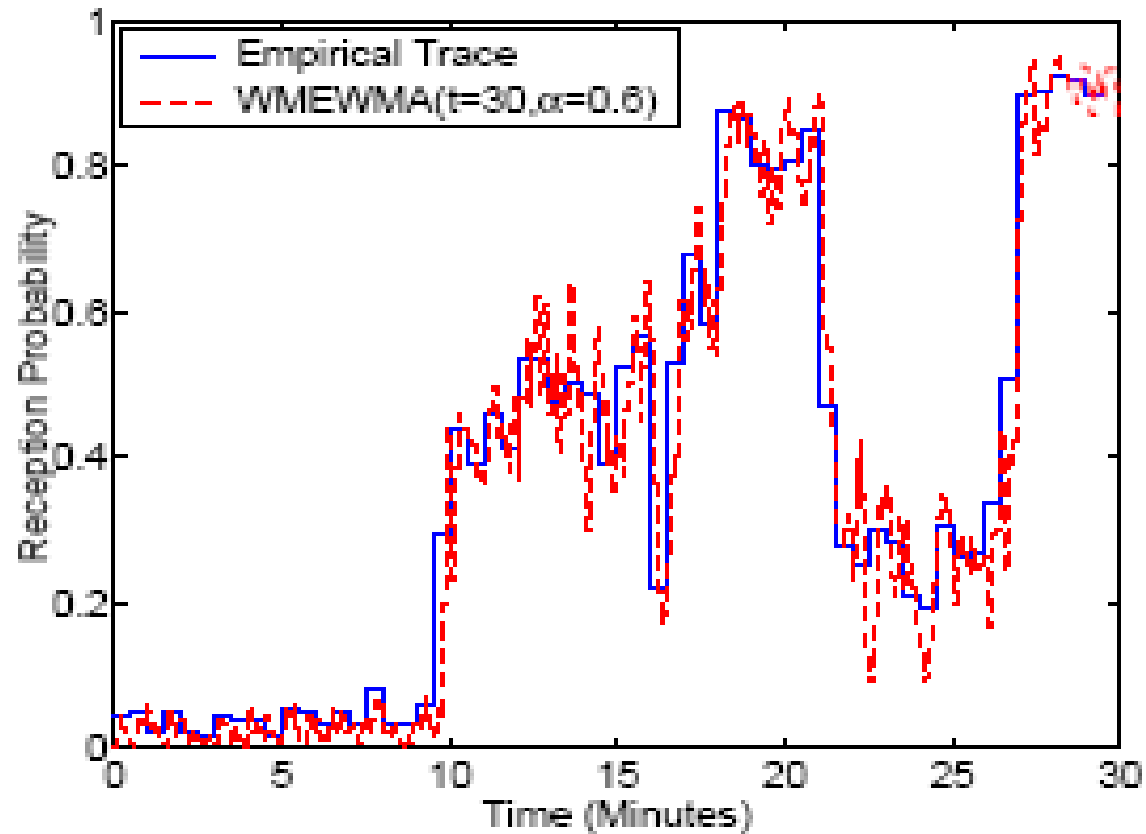

Neighborhood Management

- Neighborhood table:
 - Record information about nodes from which it receives packets (also through snooping).
- If network is dense, how does a node determine which nodes it should keep in the table?
- Keep a sufficient number of good neighbours in the table.

Link Estimation based Routing

- Focus on “many to one” routing model:
 - Information flows one way.
- Estimates of inbound links are maintained, however outbound links need to be used!
 - Propagation back to neighbours.
- Each node selects a parent (using the link estimation table).
 - Changes when link deteriorates (periodically).

Distance vector routing: cost metrics

- Routing works as a standard distance vector routing.
- The DVR cost metric is usually the hop count.
- In lossy networks hop count might underestimate costs.
 - Retransmissions on bad links: shortest path with bad links might be worse than longer path with good links.
 - Solution: consider the cost of retransmission on the whole path.

Min Transmission Routing (Mint) An Example

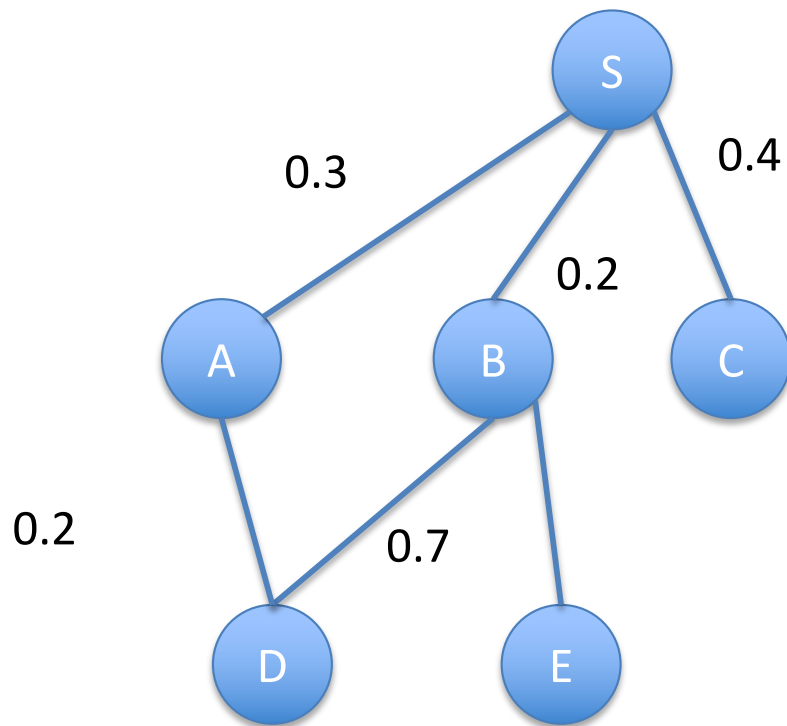

Routing Table on D:

Id	Cost	NextHop
A	0.2	A
B	0.7	B
S	0.5	A

Summary

- We have described sensor network challenges and solutions
- We have given examples of sensor network routing protocols

References

- Intanagonwiwat, C., Govindan, R., and Estrin, D. 2000. Directed diffusion: a scalable and robust communication paradigm for sensor networks. In Proceedings of the 6th Annual international Conference on Mobile Computing and Networking (Boston, Massachusetts, United States, August 06 - 11, 2000). MobiCom '00. ACM, New York, NY, 56-67.
- Woo, A., Tong, T., and Culler, D. 2003. Taming the underlying challenges of reliable multihop routing in sensor networks. In *Proceedings of the 1st international Conference on Embedded Networked Sensor Systems* (Los Angeles, California, USA, November 05 - 07, 2003). SenSys '03. ACM, New York, NY. Pages: 14-27.