

Part 1: Computer Organisation

- Some history, see also:
IEEE-CS history timeline to 1996 (with pictures)
<http://computer.org/history/development/index.html>
(and IEEE Computer, October 1996)
- Computer Lab web pages
- Operation of a simple computer
- Representation of information
 - text - source code, documents, data
 - instructions - for object code
 - numbers
- I/O, devices, interrupts, DMA

A Chronology of Early Computing

- (several BC): abacus used for counting
- 1614: logarithms invented (John Napier)
- 1622: invention of the slide rule (Robert Bissaker)
- 1642: First mechanical digital calculator (Pascal)
- Charles Babbage (U. Cambridge) invents:
 - 1812: “Difference Engine”
 - 1833: “Analytical Engine”
- 1890: First electro-mechanical punched card data-processing machine (Hollerith, later IBM)
- 1905: Vacuum tube/triode invented (De Forest)
- 1935: the relay-based *IBM 601* reaches 1 MPS.
- 1939: *ABC* — first electronic digital computer (Atanasoff & Berry, Iowa State University)
- 1941: *Z3* — first programmable computer (Zuse)
- Jan 1943: the *Harvard Mark I* (Aiken)
- Dec 1943: *Colossus* built at 'Station X', Bletchley Park (Newman, Wynn-Williams, Turing et al).

The Von Neumann Architecture

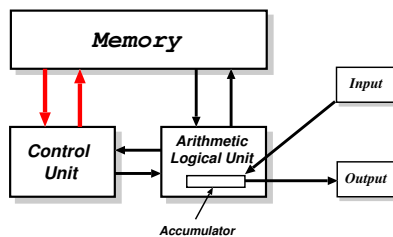

- 1945: *ENIAC* (Eckert & Mauchley, U. Penn):
 - 30 tons, 1000 square feet, 140 kW,
 - 18K vacuum tubes, 20×10-digit accumulators,
 - 100KHz, circa 300 MPS.
 - Used to calculate artillery firing tables.
 - (1946) blinking lights for the media. . .
- But: “programming” is via plugboard ⇒ v. slow.
- 1945: von Neumann drafts “EDVAC” report:
 - design for a **stored-program** machine
 - Eckert & Mauchley mistakenly unattributed

Further Progress. . .

- 1947: “point contact” transistor invented (Shockley, Bardeen & Brattain, Bell Labs)
 - 1949: *EDSAC*, the world's first (=) stored-program computer (Wilkes & Wheeler, U. Cambridge)
 - 3K vacuum tubes, 300 square feet, 12 kW,
 - 500KHz, circa 650 IPS, 225 MPS.
 - 1024 17-bit words of memory in mercury ultrasonic delay lines.
 - 31 word “operating system” (!)
 - 1954: *TRADIC*, first electronic computer without vacuum tubes (Bell Labs)
 - 1954: first silicon (junction) transistor (TI)
 - 1959: first integrated circuit (Kilby & Noyce, TI)
 - 1964: IBM System/360, based on ICs.
 - 1971: Intel 4004, first micro-processor (Ted Hoff):
 - 2300 transistors, 60 KIPS.
 - 1978: Intel 8086/8088 (used in IBM PC).
 - ~ 1980: first VLSI chip (> 100,000 transistors)
- Today: ~ 40M transistors, ~ 0.18μ, ~ 1.5 GHz.

Languages and Levels

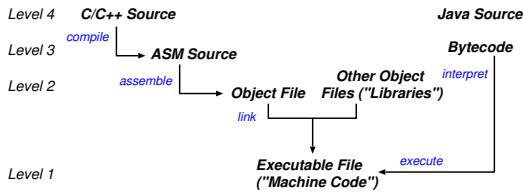

- Modern machines all programmable with a huge variety of different languages.
- e.g. ML, java, C++, C, python, perl, FORTRAN, Pascal, scheme, . . .
- We can describe the operation of a computer at a number of different *levels*; however all of these levels are *functionally equivalent*

A (Simple) Modern Computer

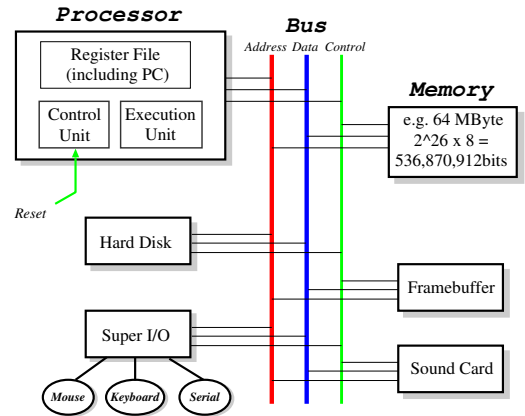

- Processor (CPU): executes programs.
- Memory: stores both programs & data.
- Devices: for input and output.
- Bus: transfers information.

Registers and the Register File

R0	0x5A	R8	0xEA02D1F
R1	0x102034	R9	0x1001D
R2	0x2030ADCB	R10	0xFFFFFFFF
R3	0x0	R11	0x102FC8
R4	0x0	R12	0xFF0000
R5	0x2405	R13	0x37B1CD
R6	0x102038	R14	0x1
R7	0x20	R15	0x20000000

Computers all about operating on information:

- information arrives into memory from input devices
- memory is an essentially large byte array which can hold any information we wish to operate on.
- computer *logically* takes values from memory, performs operations, and then stores result back.
- in practice, CPU operates on *registers*:
 - a register is an extremely fast piece of on-chip memory, usually either 32- or 64-bits in size.
 - modern CPUs have between 8 and 128 registers.
 - data values are *loaded* from memory into registers before being operated upon,
 - and results are *stored* back again.

Memory Hierarchy

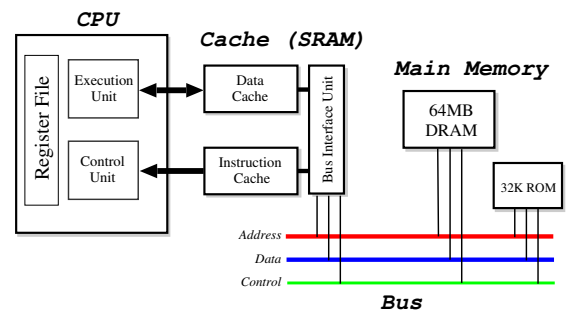

- Use *cache* between main memory and register: try to hide delay in accessing (relatively) slow DRAM.
- Cache made from faster SRAM:
 - more expensive, so much smaller
 - holds copy of subset of main memory.
- Split of instruction and data at cache level \Rightarrow "Harvard" architecture.
- Cache \leftrightarrow CPU interface uses a custom bus.
- Today have \sim 512KB cache, \sim 128MB RAM.

The Fetch-Execute Cycle

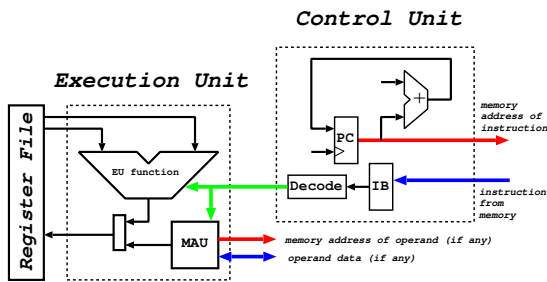

- A special register called *PC* holds a memory address; on reset, initialised to 0.
- Then:
 1. Instruction *fetched* from memory address held in *PC* into instruction buffer (*IB*).
 2. Control Unit determines what to do: *decodes* instruction.
 3. Execution Unit *executes* instruction.
 4. *PC* updated, and back to Step 1.
- Continues pretty much forever. . .

Execution Unit

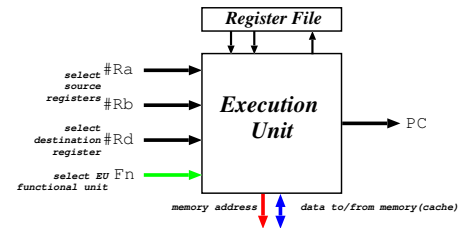

- The “calculator” part of the processor.
- Broken into parts (*functional units*), e.g.
 - Arithmetic Logic Unit (ALU).
 - Shifter/Rotator.
 - Multiplier.
 - Divider.
 - Memory Access Unit (MAU).
 - Branch Unit.
- Choice of functional unit determined by signals from control unit.

Arithmetic Logic Unit

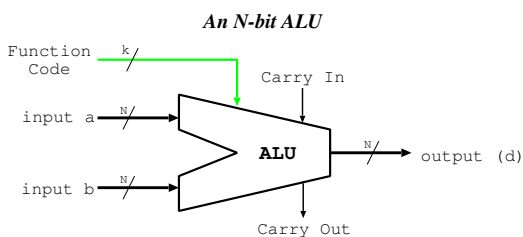

- Part of the execution unit.
- Inputs from register file; output to register file.
- Performs simple two-operand functions:
 - $a + b$
 - $a - b$
 - $a \text{ AND } b$
 - $a \text{ OR } b$
 - etc.
- Typically perform *all* possible functions; use function code to select (mux) output.

Number Representation

0000 ₂	0 ₁₆	0110 ₂	6 ₁₆	1100 ₂	C ₁₆
0001 ₂	1 ₁₆	0111 ₂	7 ₁₆	1101 ₂	D ₁₆
0010 ₂	2 ₁₆	1000 ₂	8 ₁₆	1110 ₂	E ₁₆
0011 ₂	3 ₁₆	1001 ₂	9 ₁₆	1111 ₂	F ₁₆
0100 ₂	4 ₁₆	1010 ₂	A ₁₆	10000 ₂	10 ₁₆
0101 ₂	5 ₁₆	1011 ₂	B ₁₆	10001 ₂	11 ₁₆

- a n -bit register $b_{n-1}b_{n-2} \dots b_1b_0$ can represent 2^n different values.
- Call b_{n-1} the *most significant bit* (msb), b_0 the *least significant bit* (lsb).
- Unsigned numbers: treat the obvious way, i.e. $\text{val} = b_{n-1}2^{n-1} + b_{n-2}2^{n-2} + \dots + b_12^1 + b_02^0$, e.g. $1101_2 = 2^3 + 2^2 + 2^0 = 8 + 4 + 1 = 13$.
- Represents values from 0 to $2^n - 1$ inclusive.
- For large numbers, binary is unwieldy: use hexadecimal (base 16).
- To convert, group bits into groups of 4, e.g. $1111101010_2 = 0011|1110|1010_2 = 3EA_{16}$.
- Often use “0x” prefix to denote hex, e.g. $0x107$.
- Can use dot to separate large numbers into 16-bit chunks, e.g. $0x3FFF.FFFF$.

Number Representation (2)

- What about *signed* numbers? Two main options:
- Sign & magnitude:
 - top (leftmost) bit flags if negative; remaining bits make value.
 - e.g. byte $10011011_2 \rightarrow -0011011_2 = -27$.
 - represents range $-(2^{n-1} - 1)$ to $+(2^{n-1} - 1)$
- 2's complement:
 - to get $-x$ from x , invert every bit and add 1.
 - e.g. $+27 = 00011011_2 \Rightarrow$
 $-27 = (11100100_2 + 1) = 11100101_2$.
 - treat $1000\dots000_2$ as -2^{n-1} .
 - represents range -2^{n-1} to $+(2^{n-1} - 1)$
- Note:
 - in both cases, top-bit=1 means “negative”.
- In practice, all modern computers use 2's complement. . .

Number Representation (3)

signed integers (e.g. $n=5$)
range -16 to $+15$, $-(2^{n-1})$ to $+(2^{n-1} - 1)$

10000_2	-16_{10}
10001_2	-15_{10}
10010_2	-14_{10}
...	
11101_2	-3_{10}
11110_2	-2_{10}
11111_2	-1_{10}
00000_2	0_{10}
00001_2	$+1_{10}$
00010_2	$+2_{10}$
...	
01110_2	$+14_{10}$
01111_2	$+15_{10}$

recall unsigned integers range, 0 to 31, 0 to $2^n - 1$

Unsigned Arithmetic

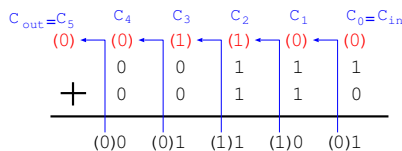

- (we use 5-bit registers for simplicity)
- Unsigned addition: C_n means “carry”:

00101	5	11110	30
$+ 00111$	7	$+ 00111$	7

$0 01100$	12	$1 00101$	5

- Unsigned subtraction: \overline{C}_n means “borrow”:

11110	30	00111	7
$+ 00101$	-27	$+ 10110$	-10

$1 00011$	3	$0 11101$	29

Signed Arithmetic

- In signed arithmetic, carry no good on its own. Use the *overflow* flag, $V = (C_n \oplus C_{n-1})$.
- Also have *negative* flag, $N = b_{n-1}$ (i.e. the msb).
- Signed addition:

00101	5	01010	10
$+ 00111$	7	$+ 00111$	7

$0 01100$	12	$0 10001$	-15

0		1	

- Signed subtraction:

01010	10	10110	-10
$+ 11001$	-7	$+ 10110$	-10

$1 00011$	3	$1 01100$	12

1		0	

- Note that in overflow cases the sign of the result is always wrong (i.e. the N bit is inverted).

Arithmetic & Logical Instructions

- Some common ALU instructions are:

Mnemonic	C/Java Equivalent
and $d \leftarrow a, b$	$d = a \& b;$
xor $d \leftarrow a, b$	$d = a \wedge b;$
bis $d \leftarrow a, b$	$d = a b;$
bic $d \leftarrow a, b$	$d = a \& (\sim b);$
add $d \leftarrow a, b$	$d = a + b;$
sub $d \leftarrow a, b$	$d = a - b;$
rsb $d \leftarrow a, b$	$d = b - a;$
shl $d \leftarrow a, b$	$d = a \ll b;$
shr $d \leftarrow a, b$	$d = a \gg b;$

Both d and a *must* be registers; b can be a register or a (small) constant.

- Typically also have `addc` and `subc`, which handle carry or borrow (for multi-precision arithmetic), e.g.

```
add d0, a0, b0 // compute "low" part.
addc d1, a1, b1 // compute "high" part.
```

- May also get:

- Arithmetic shifts: `asr` and `asl(?)`
- Rotates: `ror` and `rol`.

Conditional Execution

- Seen C, N, V ; add Z (zero), logical NOR of all bits in output.
- Can predicate execution based on (some combination) of flags, e.g.

```
sub d, a, b // compute d = a - b
beq proc1 // if equal, goto proc1
br proc2 // otherwise goto proc2
```

Java equivalent approximately:

```
if (a==b) proc1() else proc2();
```

- On most computers, mainly limited to branches.
- On ARM (and IA64), everything conditional, e.g.

```
sub d, a, b # compute d = a - b
moveq d, #5 # if equal, d = 5;
movne d, #7 # otherwise d = 7;
```

Java equiv: `d = (a==b) ? 5 : 7;`

- “Silent” versions useful when don't really want result, e.g. `tst`, `teq`, `cmp`.

Condition Codes

Suffix	Meaning	Flags
EQ, Z	Equal, zero	$Z == 1$
NE, NZ	Not equal, non-zero	$Z == 0$
MI	Negative	$N == 1$
PL	Positive (incl. zero)	$N == 0$
CS, HS	Carry, higher or same	$C == 1$
CC, LO	No carry, lower	$C == 0$
VS	Overflow	$V == 1$
VC	No overflow	$V == 0$
HI	Higher	$C == 1 \ \&\& \ Z == 0$
LS	Lower or same	$C == 0 \ \ Z == 1$
GE	Greater than or equal	$N == V$
GT	Greater than	$N == V \ \&\& \ Z == 0$
LT	Less than	$N != V$
LE	Less than or equal	$N != V \ \ Z == 1$

- HS, LO, etc. used for unsigned comparisons (recall that \overline{C} means “borrow”).
- GE, LT, etc. used for signed comparisons: check both N and V so always works.

Loads & Stores

- Have variable sized values, e.g. bytes (8-bits), halfwords (16-bits), words (32-bits) and longwords (64-bits).
- Load or store instructions usually have a suffix to determine the size, e.g. ‘b’ for byte, ‘w’ for word, ‘l’ for longword.
- When storing > 1 byte, have two main options: big endian and little endian; e.g. storing word `0xDEADBEEF` into memory at address `0x4`.

Big Endian

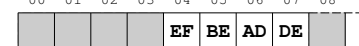

Little Endian

If read back a *byte* from address `0x4`, get `0xDE` if big-endian, or `0xEF` if little-endian.

- Today have x86 & Alpha little endian; Sparc & 68K, big endian; Mips & ARM either.

Addressing Modes

- An *addressing mode* tells the computer where the data for an instruction is to come from.
- Get a wide variety, e.g.

Register:	add	r1, r2, r3
Immediate:	add	r1, r2, #25
PC Relative:	beq	0x20
Register Indirect:	ldr	r1, [r2]
" + Displacement:	str	r1, [r2, #8]
Indexed:	movl	r1, (r2, r3)
Absolute/Direct:	movl	r1, \$0xF1EA0130
Memory Indirect:	addl	r1, (\$0xF1EA0130)
- Most modern machines are *load/store* \Rightarrow only support first five:
 - allow at most one memory ref per instruction
 - (there are very good reasons for this)
- Note that CPU generally doesn't care *what* is being held within the memory.
- i.e. up to *programmer* to interpret whether data is an integer, a pixel or a few characters in a novel.

Representing Text

- Two main standards:
 1. ASCII: 7-bit code holding (English) letters, numbers, punctuation and a few other characters.
 2. Unicode: 16-bit code supporting practically all international alphabets and symbols.
- ASCII default on many operating systems, and on the early Internet (e.g. e-mail).
- Unicode becoming more popular (esp UTF-8).
- In both cases, represent in memory as either *strings* or *arrays*: e.g. Pub Time!

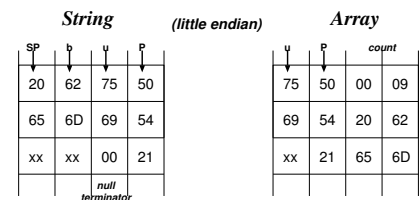

Floating Point (1)

- In many cases want to deal with very large or very small numbers.
 - Use idea of "scientific notation", e.g. $n = m \times 10^e$
 - m is called the *mantissa*
 - e is called the *exponent*.
 e.g. $C = 3.01 \times 10^8$ m/s.
 - For computers, use binary i.e. $n = m \times 2^e$, where m includes a "binary point".
 - Both m and e can be positive or negative; typically
 - sign of mantissa given by an additional *sign* bit.
 - exponent is stored in a *biased (excess)* format.
- \Rightarrow use $n = (-1)^s m \times 2^{e-b}$, where $0 \leq m < 2$ and b is the bias.
- e.g. 4-bit mantissa & 3-bit bias-3 exponent allows positive range $[0.001_2 \times 2^{-3}, 1.111_2 \times 2^4]$
- $= [(\frac{1}{8})(\frac{1}{8}), (\frac{15}{8})16]$, or $[\frac{1}{64}, 30]$

Floating Point (2)

- In practice use IEEE floating point with *normalised* mantissa $m = 1.xx \dots x_2$
 \Rightarrow use $n = (-1)^s((1 + m) \times 2^{e-b})$,
- Both single (float) and double (double) precision:

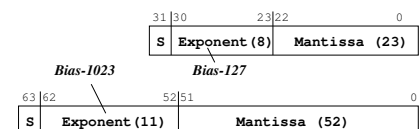

- IEEE fp reserves $e = 0$ and $e = \text{max}$:
 - ± 0 (!): both e and m zero.
 - $\pm \infty$: $e = \text{max}$, m zero.
 - NaNs: $e = \text{max}$, m non-zero.
 - denorms: $e = 0$, m non-zero
- Normal positive range $[2^{-126}, \sim 2^{128}]$ for single, or $[2^{-1022}, \sim 2^{1024}]$ for double.
- NB: still only $2^{32}/2^{64}$ values — just spread out.

Data Structures

- Records / structures: each field stored as an offset from a *base address*.
- Variable size structures: explicitly store addresses (*pointers*) inside structure, e.g.

```
datatype rec = node of int * int * rec
            | leaf of int;
```

```
val example = node(4, 5, node(6, 7, leaf(8)));
```

for `example` above stored at address `0x1000`:

Address	Value	Comment
0x0F30	0xFFFF	Constructor tag for a leaf
0x0F34	8	Integer 8
⋮		
0x0F3C	0xFFFE	Constructor tag for a node
0x0F40	6	Integer 6
0x0F44	7	Integer 7
0x0F48	0x0F30	Base address of inner node
⋮		
0x1000	0xFFFE	Constructor tag for a node
0x1004	4	Integer 4
0x1008	5	Integer 5
0x100C	0x0F3C	Base address of inner node

Instruction Encoding

- An instruction comprises:
 - an *opcode*: specify what to do.
 - zero or more *operands*: where to get/put values
 e.g. `add r1, r2, r3` ≡

1010111	001	010	011
---------	-----	-----	-----
- Old machines (and x86) use *variable length* encoding motivated by low code density.
- Most modern machines use fixed length encoding for simplicity. e.g. ARM ALU operations.

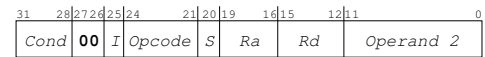

`and r13, r13, #31` = `0xe20dd01f` =

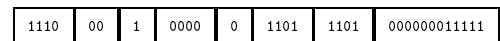

`bic r3, r3, r2` = `0xe1c33002` =

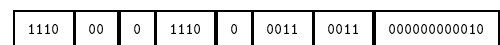

`cmp r1, r2` = `0xe1510002` =

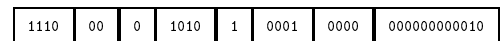

Fetch-Execute Cycle Revisited

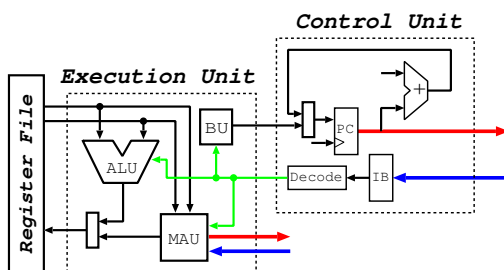

- CU fetches & decodes instruction and generates (a) control signals and (b) operand information.
- Inside EU, control signals select functional unit ("instruction class") and operation.
- If ALU, then read one or two registers, perform operation, and (probably) write back result.
- If BU, test condition and (maybe) add value to PC.
- If MAU, generate address ("addressing mode") and use bus to read/write value.
- Repeat *ad infinitum*.

Input/Output Devices

- Devices connected to processor via a *bus* (e.g. ISA, PCI, AGP).
- Includes a wide range:
 - Mouse,
 - Keyboard,
 - Graphics Card,
 - Sound card,
 - Floppy drive,
 - Hard-Disk,
 - CD-Rom,
 - Network card,
 - Printer,
 - Modem
 - etc.
- Often two or more stages involved (e.g. IDE, SCSI, RS-232, Centronics, etc.)

UARTs

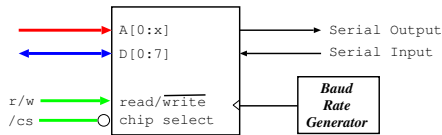

- Universal Asynchronous Receiver/Transmitter:
 - stores 1 or more bytes internally.
 - converts parallel to serial.
 - outputs according to RS-232.
- Various baud rates (e.g. 1,200 – 115,200)
- Slow and simple. . . and very useful.
- Make up “serial ports” on PC.
- Max throughput $\sim 14.4\text{KBytes}$; variants up to 56K (for modems).

Hard Disks

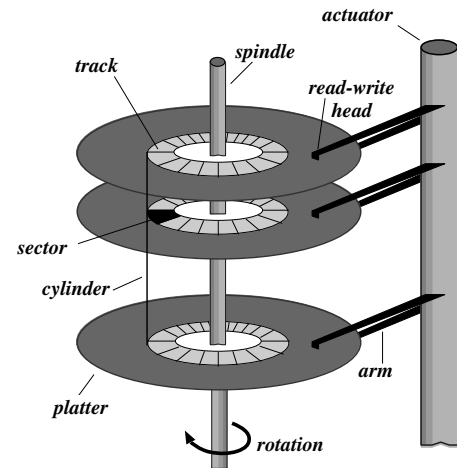

- Whirling bits of (magnetized) metal. . .
- Rotate 3,600 – 7,200 times a minute.
- Capacity $\sim 40\text{ GBytes}$ ($\approx 40 \times 2^{30}\text{bytes}$).

Hard Disks (2)

- arms move together - address a cylinder
- heads “float” - sealed unit else head crashes
- to read or write
 - move heads to cylinder (SEEK)
 - wait for sector (rotational LATENCY)
 - activate relevant head and transfer data
- can take 10s of ms if seek needed
- transfer rate about 10Mbytes/sec
- modern disks may have
 - processor (disk controller)
 - cache memory
 - use scatter-gather (batch of requests for blocks)

Graphics Cards

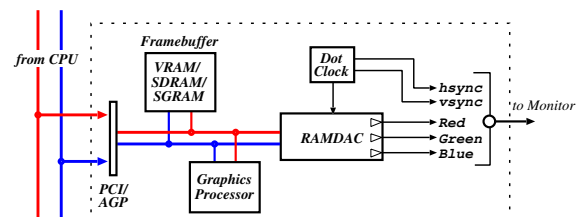

- Essentially some RAM (framebuffer) and some digital-to-analogue circuitry (RAMDAC).
 - RAM holds array of *pixels*: picture elements.
 - Resolutions e.g. 640x480, 800x600, 1024x768, 1280x1024, 1600x1200.
 - Depths: 8-bit (LUT), 16-bit (RGB=555, 24-bit (RGB=888), 32-bit (RGBA=888).
 - Memory requirement = $x \times y \times \text{depth}$, e.g. 1024x768 @ 16bpp needs 1536KB.
- ⇒ full-screen 50Hz video requires 7.5MBytes/s (or 60Mbits/s).

Buses

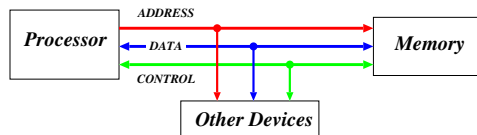

- Bus = collection of *shared* communication wires:
 - ✓ low cost.
 - ✓ versatile / extensible.
 - ✗ potential bottle-neck.
- Typically comprises address lines, data lines and control lines (+ power/ground).
- Operates in a *master-slave* manner, e.g.
 1. master decides to e.g. read some data.
 2. master puts addr onto bus and asserts 'read'
 3. slave reads addr from bus and retrieves data.
 4. slave puts data onto bus.
 5. master reads data from bus.

Bus Hierarchy

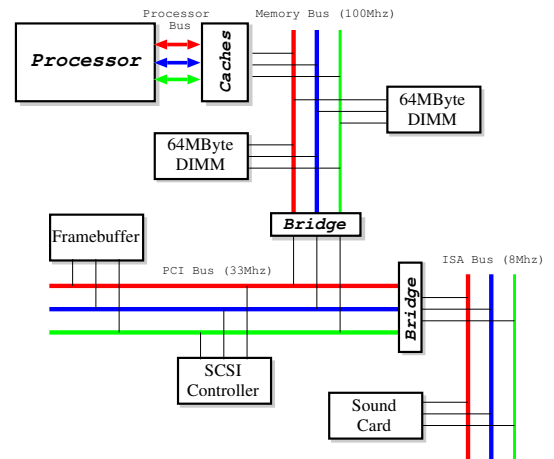

- In practice, have lots of different buses with different characteristics e.g. data width, max #devices, max length.
- Most buses are *synchronous* (share clock signal).

Interrupts

- Bus reads and writes are *transaction* based: CPU requests something and waits until it happens.
- But e.g. reading a block of data from a hard-disk takes $\sim 2ms$, which is $\sim 1,000,000$ clock cycles!
- *Interrupts* provide a way to decouple CPU requests from device responses.
 1. CPU uses bus to make a request (e.g. *writes* some special values to a device).
 2. Device goes off to get info.
 3. Meanwhile CPU continues doing other stuff.
 4. When device finally has information, raises an *interrupt*.
 5. CPU uses bus to read info from device.
- When interrupt occurs, CPU selects handler, then *resumes* using special instruction, e.g.

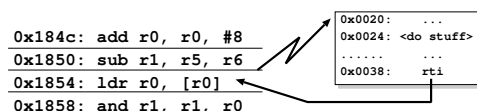

Interrupts (2)

- Interrupt lines ($\sim 4 - 8$) are part of the bus.
- Often only 1 or 2 pins on chip \Rightarrow need to encode.
- e.g. ISA bus (8 lines) & x86:

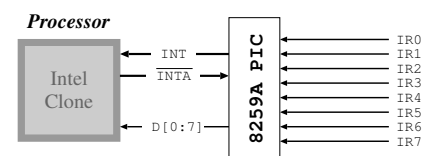

1. Device asserts IR_x .
2. PIC encoder asserts INT.
3. When CPU can take interrupt, strobes INTA.
4. PIC sends interrupt number on $D[0:7]$.
5. CPU uses number to index ("vector") into a table in memory which holds the addresses of the handlers of every interrupt.
6. CPU saves (some) registers and jumps to handler.

Direct Memory Access (DMA)

- a DMA device can read and write processor memory *directly*.
- A generic DMA “command” might include
 - source address
 - source increment / decrement / do nothing
 - sink address
 - sink increment / decrement / do nothing
 - transfer size
- Get one interrupt at end of data transfer
- DMA channels may be provided by devices themselves:
 - e.g. a disk controller
 - pass disk address, memory address and size
 - give instruction to read or write
- Also get “stand-alone” programmable DMA controllers.

Hardware used by OS (for Part 2)

- the interrupt mechanism for entry into OS:
 - hardware transfer of control to interrupt service routine (ISR) - *in the OS*, including processor state saving (PC, PSR, other registers ...)
 - an instruction to return from interrupt/exception, including restoring of saved processor state
- instructions which cause “software interrupts”/exceptions so cause transfer into an ISR - *in the OS*.
- timers - peripherals which are used to interrupt as programmed
- processor status register(PSR) including a bit to indicate:
 - user mode (unprivileged mode)
 - system mode (privileged mode)

Summary of Part 1

- Computers made up of four main parts:
 1. Processor (including register file, control unit and execution unit),
 2. Memory (caches, RAM, ROM),
 3. Devices (disks, graphics cards, etc.), and
 4. Buses (interrupts, DMA).
 - Information represented in all sorts of formats:
 - signed & unsigned integers,
 - strings,
 - floating point,
 - data structures,
 - instructions.
 - Can (hopefully) understand all of these at some level, but gets pretty complex.
- ⇒ to be able to actually *use* a computer, need an operating system.