

Artificial Intelligence I

Machine learning using neural networks

Reading: AIMA, chapter 20.

Did you heed the DIRE WARNING?

At the beginning of the course I suggested making sure you can answer the following two questions:

1. Let

$$f(x_1, \dots, x_n) = \sum_{i=1}^n a_i x_i^2$$

where the a_i are constants. Compute $\partial f / \partial x_j$ where $1 \leq j \leq n$?

Answer: As only one term in the sum depends on x_j , all the other terms differentiate to give 0 and

$$\frac{\partial f}{\partial x_j} = 2a_j x_j.$$

2. Let $f(x_1, \dots, x_n)$ be a function. Now assume $x_i = g_i(y_1, \dots, y_m)$ for each x_i and some collection of functions g_i . Assuming all requirements for differentiability and so on are met, can you write down an expression for $\partial f / \partial y_j$ where $1 \leq j \leq m$?

Answer: this is just the *chain rule* for partial differentiation

$$\frac{\partial f}{\partial y_j} = \sum_{i=1}^n \frac{\partial f}{\partial g_i} \frac{\partial g_i}{\partial y_j}.$$

Supervised learning with neural networks

We now consider how an agent might *learn* to solve a general problem by seeing *examples*:

- I present an outline of *supervised learning*.
- I introduce the classical *perceptron*.
- I introduce *multilayer perceptrons* and the *backpropagation algorithm* for training them.

To begin, a common source of problems in AI is *medical diagnosis*.

Imagine that we want to automate the diagnosis of an **Embarrassing Disease** (call it D) by constructing a machine:

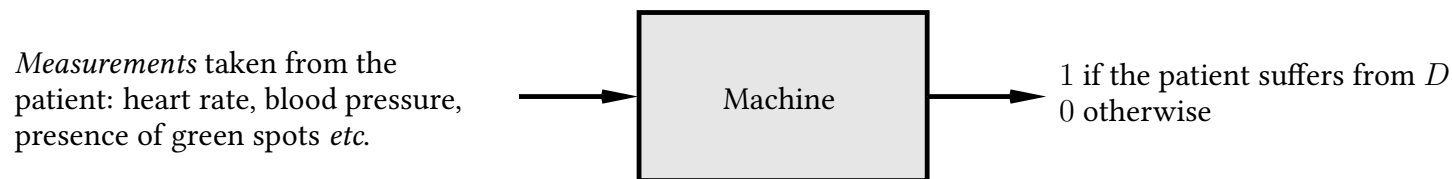

Could we do this by *explicitly writing a program* that examines the measurements and outputs a diagnosis? Experience suggests that this is unlikely.

An example, continued...

An alternative approach: each collection of measurements can be written as a vector,

$$\mathbf{x}^T = (x_1 \ x_2 \ \cdots \ x_n)$$

where,

$x_1 =$ heart rate

$x_2 =$ blood pressure

$x_3 = 1$ if the patient has green spots, and 0 otherwise

\vdots

and so on.

(*Note: it's a common convention that vectors are *column vectors* by default. This is why the above is written as a *transpose*.*)

An example, continued...

A vector of this kind contains all the measurements for a single patient and is called a *feature vector* or *instance*.

The measurements are *attributes* or *features*.

Attributes or features generally appear as one of three basic types:

- *Continuous*: $x_i \in [x_{\min}, x_{\max}]$ where $x_{\min}, x_{\max} \in \mathbb{R}$.
- *Binary*: $x_i \in \{0, 1\}$ or $x_i \in \{-1, +1\}$.
- *Discrete*: x_i can take one of a finite number of values, say $x_i \in \{X_1, \dots, X_p\}$.

An example, continued...

Now imagine that we have a large collection of patient histories (m in total) and for each of these we know whether or not the patient suffered from D .

- The i th patient history gives us an instance \mathbf{x}_i .
- This can be paired with a single bit—0 or 1—denoting whether or not the i th patient suffers from D . The resulting pair is called an *example* or a *labelled example*.
- Collecting all the examples together we obtain a *training sequence*

$$\mathbf{s} = ((\mathbf{x}_1, 0), (\mathbf{x}_2, 1), \dots, (\mathbf{x}_m, 0)).$$

An example, continued...

In supervised machine learning we aim to design a *learning algorithm* which takes s and produces a *hypothesis* h .

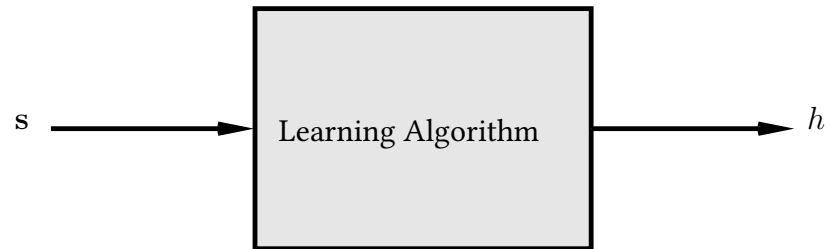

Intuitively, a hypothesis is something that lets us diagnose *new* patients.

This is *IMPORTANT*: we want to diagnose patients that *the system has never seen*.

The ability to do this successfully is called *generalisation*.

An example, continued...

In fact, a hypothesis is just a *function* that maps *instances* to *labels*.

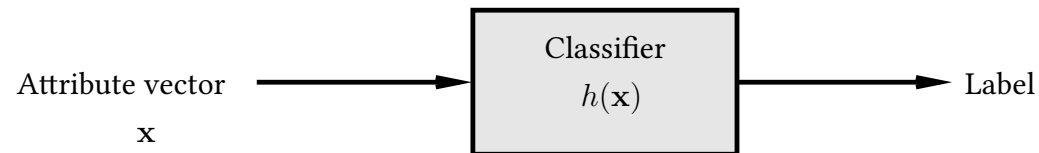

As h is a *function* it assigns a label to *any* x and *not just the ones that were in the training sequence*.

What we mean by a *label* here depends on whether we're doing *classification* or *regression*.

Supervised learning: classification and regression

In *classification* we're assigning \mathbf{x} to one of a set $\{\omega_1, \dots, \omega_c\}$ of c classes. For example, if \mathbf{x} contains measurements taken from a patient then there might be three classes:

$\omega_1 =$ patient has disease

$\omega_2 =$ patient doesn't have disease

$\omega_3 =$ don't ask me buddy, I'm just a computer!

The *binary* case above also fits into this framework, and we'll often specialise to the case of two classes, denoted C_1 and C_2 .

In *regression* we're assigning \mathbf{x} to a *real number* $h(\mathbf{x}) \in \mathbb{R}$. For example, if \mathbf{x} contains measurements taken regarding today's weather then we might have

$h(\mathbf{x}) =$ estimate of amount of rainfall expected tomorrow.

For the *two-class classification problem* we will also refer to a situation somewhat between the two, where

$$h(\mathbf{x}) = \Pr(\mathbf{x} \text{ is in } C_1)$$

and so we would typically assign \mathbf{x} to class C_1 if $h(\mathbf{x}) > 1/2$.

Summary

We don't want to design h explicitly.

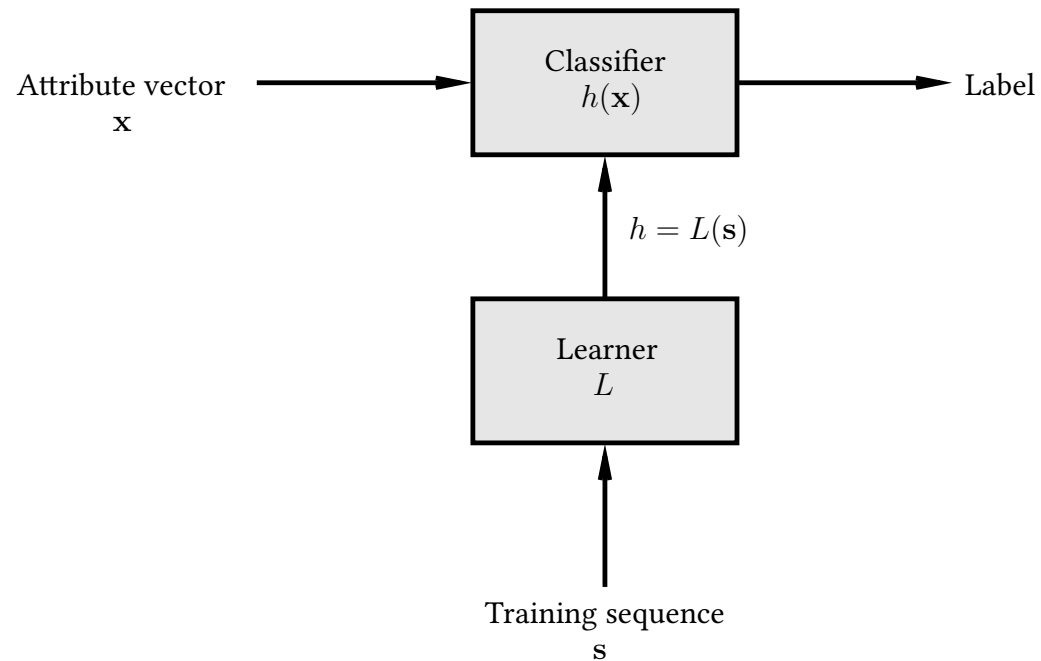

So we use a *learner* L to infer it on the basis of a sequence s of *training examples*.

Neural networks

There is generally a set \mathcal{H} of hypotheses from which L is allowed to select h

$$L(\mathbf{s}) = h \in \mathcal{H}$$

\mathcal{H} is called the *hypothesis space*.

The learner can output a hypothesis explicitly or—as in the case of a *neural network*—it can output a vector

$$\mathbf{w}^T = (w_1 \ w_2 \ \cdots \ w_W)$$

of *weights* which in turn specify h

$$h(\mathbf{x}) = f(\mathbf{w}; \mathbf{x})$$

where $\mathbf{w} = L(\mathbf{s})$.

Types of learning

The form of machine learning described is called *supervised learning*. The literature also discusses *unsupervised learning*, *semisupervised learning*, learning using *membership queries* and *equivalence queries*, and *reinforcement learning*. (More about some of this next year...)

Supervised learning has multiple applications:

- *Speech recognition.*
- Deciding *whether or not to give credit.*
- Detecting *credit card fraud.*
- Deciding whether to *buy or sell a stock option.*
- Deciding whether a *tumour is benign.*
- *Data mining*: extracting interesting but hidden knowledge from existing, large databases. For example, databases containing *financial transactions* or *loan applications*.
- *Automatic driving.* (See Pomerleau, 1989, in which a car is driven for 90 miles at 70 miles per hour, on a public road with other cars present, but with no assistance from humans.)

This is very similar to curve fitting

This process is in fact very similar to *curve fitting*. Think of the process as follows:

- Nature picks an $h' \in \mathcal{H}$ but doesn't reveal it to us.
- Nature then shows us a training sequence s where each \mathbf{x}_i is labelled as $h'(\mathbf{x}_i) + \epsilon_i$ where ϵ_i is noise of some kind.

Our job is to try to infer what h' is *on the basis of s only*. *Example:* if \mathcal{H} is the set of all polynomials of degree 3 then nature might pick $h'(x) = \frac{1}{3}x^3 - \frac{3}{2}x^2 + 2x - \frac{1}{2}$.

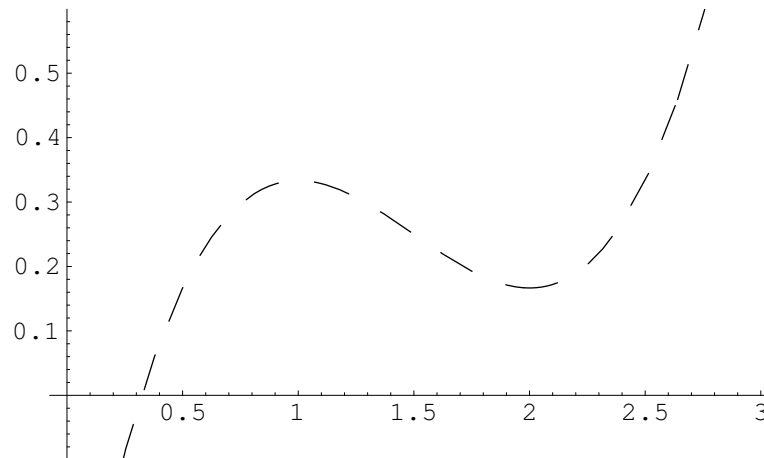

The line is dashed to emphasise the fact that *we don't get to see it*.

Curve fitting

We can now use h' to obtain a training sequence \mathbf{s} in the manner suggested..

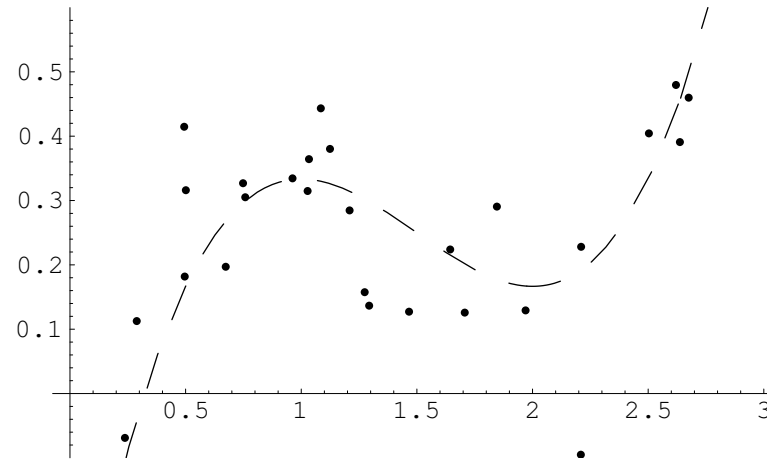

Here we have,

$$\mathbf{s}^T = ((x_1, y_1), (x_2, y_2), \dots, (x_m, y_m))$$

where each x_i and y_i is a real number.

Curve fitting

We'll use a *learning algorithm* L that operates in a reasonable-looking way: it picks an $h \in \mathcal{H}$ minimising the following quantity,

$$E = \sum_{i=1}^m (h(x_i) - y_i)^2.$$

In other words

$$h = L(\mathbf{s}) = \operatorname{argmin}_{h \in \mathcal{H}} \sum_{i=1}^m (h(x_i) - y_i)^2.$$

Why is this sensible?

1. Each term in the sum is 0 if $h(x_i)$ is *exactly* y_i .
2. Each term *increases* as the difference between $h(x_i)$ and y_i increases.
3. We add the terms for all examples.

Curve fitting

If we pick h using this method then we get:

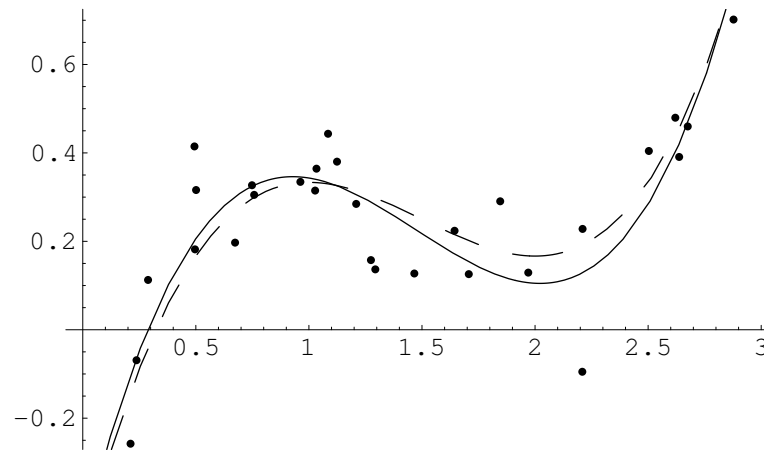

The chosen h is close to the target h' , even though it was chosen *using only a small number of noisy examples*.

It is not quite identical to the target concept.

However if we were given a new point \mathbf{x}' and asked to guess the value $h'(\mathbf{x}')$ then guessing $h(\mathbf{x}')$ might be expected to do quite well.

Curve fitting

Problem: we don't know *what \mathcal{H} nature is using*. What if the one we choose doesn't match? We can make *our \mathcal{H}* 'bigger' by defining it as

$$\mathcal{H} = \{h : h \text{ is a polynomial of degree at most } 5\}.$$

If we use the same learning algorithm then we get:

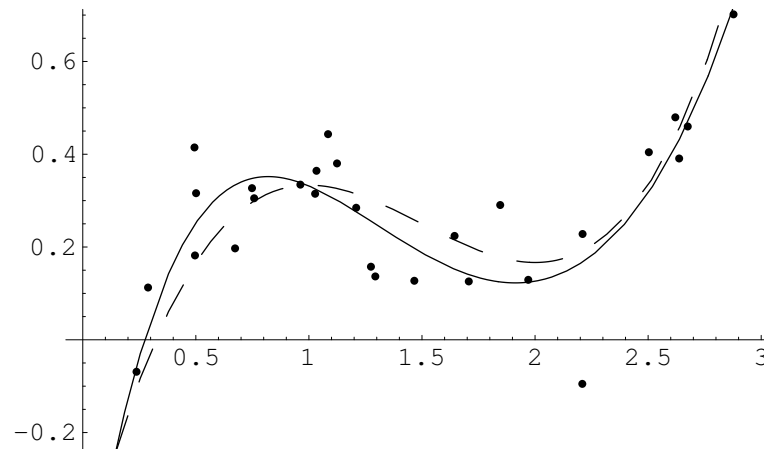

The result in this case is similar to the previous one: h is again quite close to h' , but not quite identical.

Curve fitting

So what's the problem? Repeating the process with,

$$\mathcal{H} = \{h : h \text{ is a polynomial of degree at most } 1\}$$

gives the following:

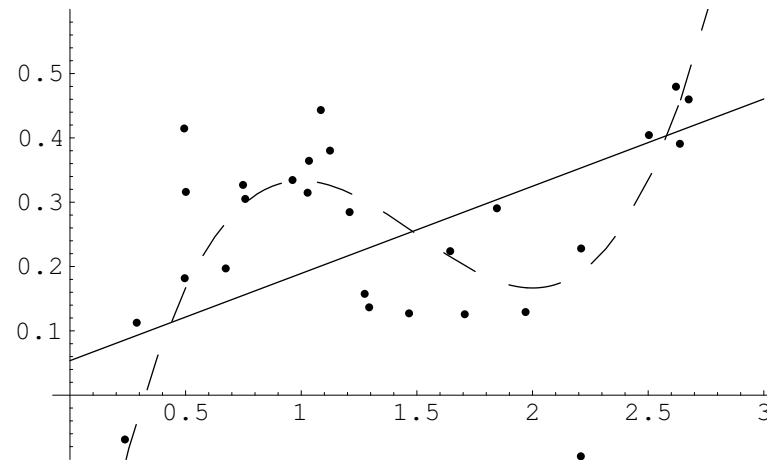

In effect, we have made *our* \mathcal{H} too 'small'. It does not in fact contain any hypothesis similar to h' .

Curve fitting

So we have to make \mathcal{H} huge, right? *WRONG!!!* With

$$\mathcal{H} = \{h : h \text{ is a polynomial of degree at most } 25\}$$

we get:

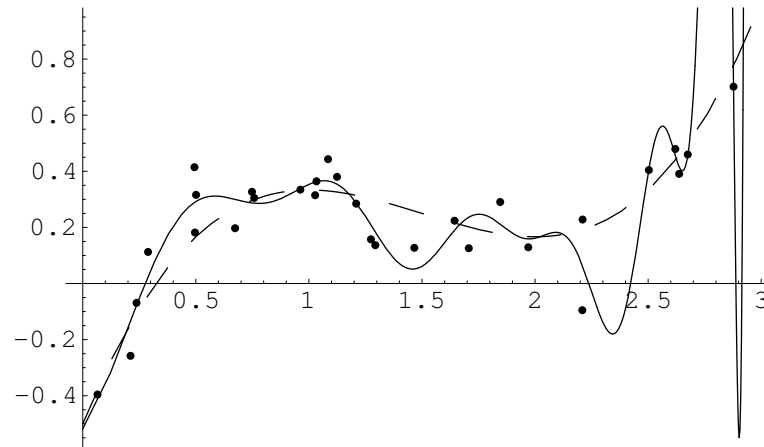

BEWARE!!! This is known as *overfitting*.

The perceptron

The example just given illustrates much of what we want to do. However in practice we deal with *more than a single dimension*, so

$$\mathbf{x}^T = (x_1 \ x_2 \ \cdots \ x_n).$$

The simplest form of hypothesis used is the *linear discriminant*, also known as the *perceptron*. Here

$$h(\mathbf{w}; \mathbf{x}) = \sigma \left(w_0 + \sum_{i=1}^n w_i x_i \right) = \sigma (w_0 + w_1 x_1 + w_2 x_2 + \cdots + w_n x_n).$$

So: we have a *linear function* modified by the *activation function* σ .

The perceptron's influence continues to be felt in the recent and ongoing development of *support vector machines*, and forms the basis for most of the field of supervised learning.

The perceptron activation function I

There are three standard forms for the activation function:

1. *Linear*: for *regression problems* we often use

$$\sigma(z) = z.$$

2. *Step*: for *two-class classification problems* we often use

$$\sigma(z) = \begin{cases} C_1 & \text{if } z > 0 \\ C_2 & \text{otherwise.} \end{cases}$$

3. *Sigmoid/Logistic*: for *probabilistic classification* we often use

$$\Pr(\mathbf{x} \text{ is in } C_1) = \sigma(z) = \frac{1}{1 + \exp(-z)}.$$

The *step function* is important but the algorithms involved are somewhat different to those we'll be seeing. We won't consider it further.

The *sigmoid/logistic function* plays a major role in what follows.

The sigmoid/logistic function

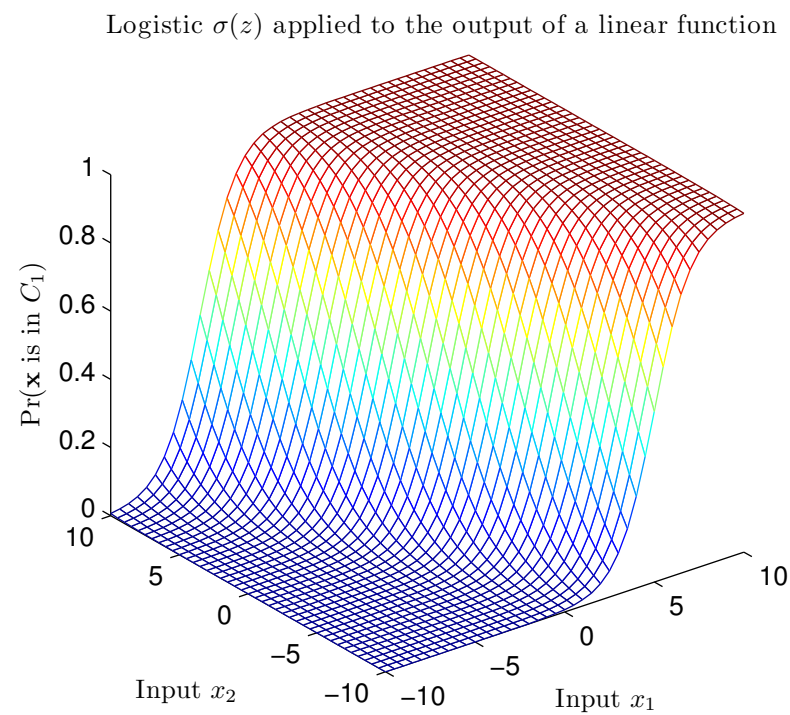
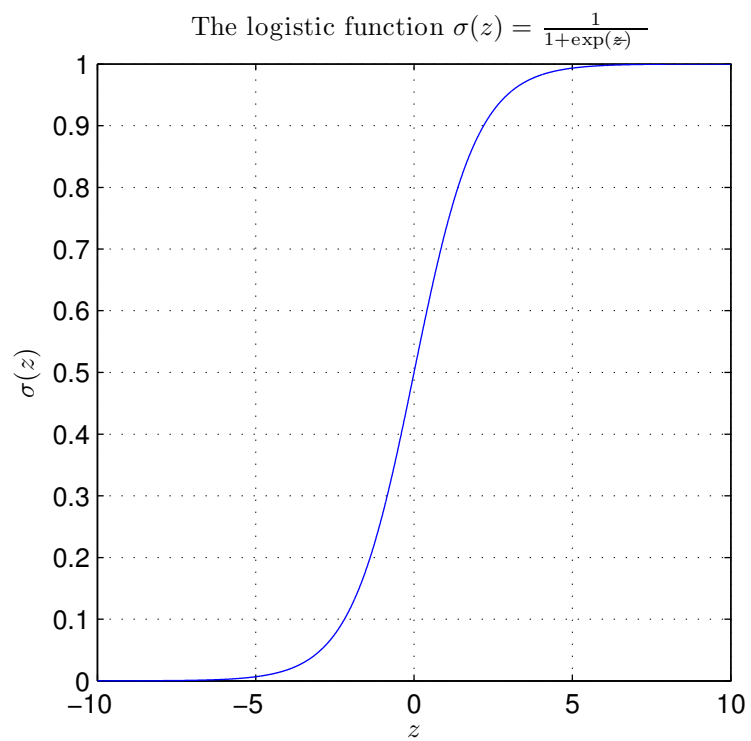

Gradient descent

A method for *training a basic perceptron* works as follows. Assume we're dealing with a *regression problem* and using $\sigma(z) = z$.

We define a measure of *error* for a given collection of weights. For example

$$E(\mathbf{w}) = \sum_{i=1}^m (y_i - h(\mathbf{w}; \mathbf{x}_i))^2.$$

Modifying our notation slightly so that

$$\begin{aligned}\mathbf{x}^T &= (1 \ x_1 \ x_2 \ \cdots \ x_n) \\ \mathbf{w}^T &= (w_0 \ w_1 \ w_2 \ \cdots \ w_n)\end{aligned}$$

lets us write

$$E(\mathbf{w}) = \sum_{i=1}^m (y_i - \mathbf{w}^T \mathbf{x}_i)^2.$$

We want to *minimise* $E(\mathbf{w})$.

Gradient descent

One way to approach this is to start with a random \mathbf{w}_0 and update it as follows:

$$\mathbf{w}_{t+1} = \mathbf{w}_t - \eta \left. \frac{\partial E(\mathbf{w})}{\partial \mathbf{w}} \right|_{\mathbf{w}_t}$$

where

$$\frac{\partial E(\mathbf{w})}{\partial \mathbf{w}} = \left(\frac{\partial E(\mathbf{w})}{\partial w_0} \quad \frac{\partial E(\mathbf{w})}{\partial w_1} \quad \dots \quad \frac{\partial E(\mathbf{w})}{\partial w_n} \right)^T$$

and η is some small positive number.

The vector

$$-\frac{\partial E(\mathbf{w})}{\partial \mathbf{w}}$$

tells us the *direction of the steepest decrease in $E(\mathbf{w})$* .

Gradient descent

With

$$E(\mathbf{w}) = \sum_{i=1}^m (y_i - \mathbf{w}^T \mathbf{x}_i)^2$$

we have

$$\begin{aligned} \frac{\partial E(\mathbf{w})}{\partial w_j} &= \frac{\partial}{\partial w_j} \left(\sum_{i=1}^m (y_i - \mathbf{w}^T \mathbf{x}_i)^2 \right) \\ &= \sum_{i=1}^m \left(\frac{\partial}{\partial w_j} (y_i - \mathbf{w}^T \mathbf{x}_i)^2 \right) \\ &= \sum_{i=1}^m \left(2(y_i - \mathbf{w}^T \mathbf{x}_i) \frac{\partial}{\partial w_j} (-\mathbf{w}^T \mathbf{x}_i) \right) \\ &= -2 \sum_{i=1}^m \mathbf{x}_i^{(j)} (y_i - \mathbf{w}^T \mathbf{x}_i) \end{aligned}$$

where $\mathbf{x}_i^{(j)}$ is the j th element of \mathbf{x}_i .

Gradient descent

The method therefore gives the algorithm

$$\mathbf{w}_{t+1} = \mathbf{w}_t + 2\eta \sum_{i=1}^m (y_i - \mathbf{w}_t^T \mathbf{x}_i) \mathbf{x}_i$$

Some things to note:

- In this case $E(\mathbf{w})$ is *parabolic* and has a *unique global minimum* and *no local minima* so this works well.
- *Gradient descent* in some form is a very common approach to this kind of problem.
- We can perform a similar calculation for *other activation functions* and for *other definitions for $E(\mathbf{w})$* .
- Such calculations lead to *different algorithms*.

Perceptrons aren't very powerful: the parity problem

There are many problems a perceptron can't solve.

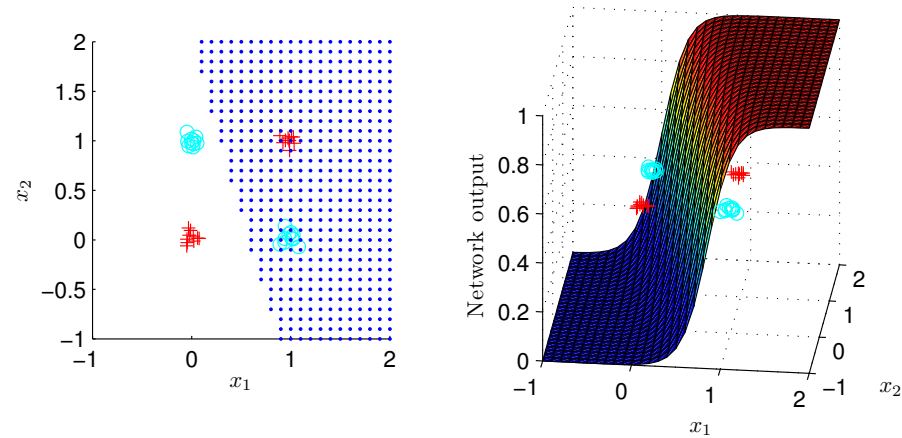

We need a network that computes *more interesting functions*.

The multilayer perceptron

Each *node* in the network is itself a perceptron:

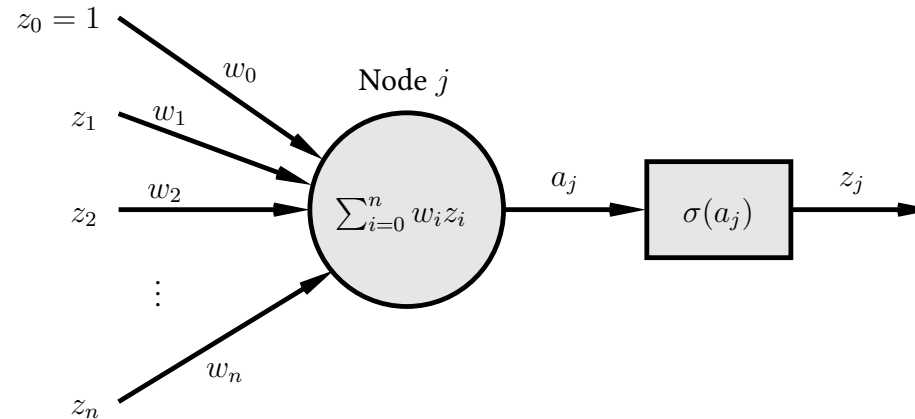

Weights w_i connect nodes together, and a_j is the weighted sum or *activation* for node j . σ is the *activation function* and the *output* is $z_j = \sigma(a_j)$.

Reminder: we'll continue to use the notation

$$\mathbf{z}^T = (1 \ z_1 \ z_2 \ \cdots \ z_n)$$
$$\mathbf{w}^T = (w_0 \ w_1 \ w_2 \ \cdots \ w_n)$$

so that

$$\sum_{i=0}^n w_i z_i = w_0 + \sum_{i=1}^n w_i z_i = \mathbf{w}^T \mathbf{z}.$$

The multilayer perceptron

In the general case we have a *completely unrestricted feedforward structure*:

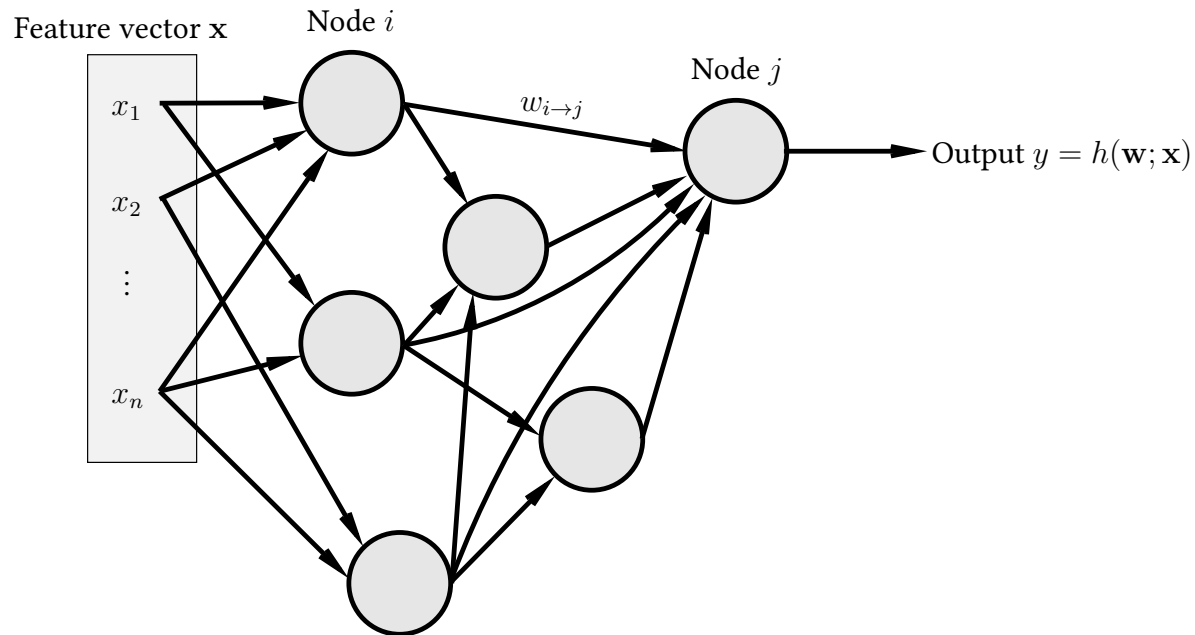

Each node is a perceptron. No specific layering is assumed.

$w_{i \rightarrow j}$ connects node i to node j . w_0 for node j is denoted $w_{0 \rightarrow j}$.

Backpropagation

As usual we have:

- Instances $\mathbf{x}^T = (x_1, \dots, x_n)$.
- A training sequence $\mathbf{s} = ((\mathbf{x}_1, y_1), \dots, (\mathbf{x}_m, y_m))$.

We also define a measure of training error

$$E(\mathbf{w}) = \text{measure of the error of the network on } \mathbf{s}$$

where \mathbf{w} is the vector of *all the weights in the network*.

Our aim is to find a set of weights that *minimises* $E(\mathbf{w})$ using *gradient descent*.

Backpropagation: the general case

The *central task* is therefore to calculate

$$\frac{\partial E(\mathbf{w})}{\partial \mathbf{w}}$$

To do that we need to calculate the individual quantities

$$\frac{\partial E(\mathbf{w})}{\partial w_{i \rightarrow j}}$$

for *every weight* $w_{i \rightarrow j}$ in the network.

Often $E(\mathbf{w})$ is the sum of separate components, one for each example in \mathbf{s}

$$E(\mathbf{w}) = \sum_{p=1}^m E_p(\mathbf{w})$$

in which case

$$\frac{\partial E(\mathbf{w})}{\partial \mathbf{w}} = \sum_{p=1}^m \frac{\partial E_p(\mathbf{w})}{\partial \mathbf{w}}$$

We can therefore consider examples individually.

Backpropagation: the general case

Place example p at the input and calculate a_j and z_j for *all nodes* including the output y . This is *forward propagation*.

We have

$$\frac{\partial E_p(\mathbf{w})}{\partial w_{i \rightarrow j}} = \frac{\partial E_p(\mathbf{w})}{\partial a_j} \frac{\partial a_j}{\partial w_{i \rightarrow j}}$$

where $a_j = \sum_k w_{k \rightarrow j} z_k$.

Here the sum is over *all the nodes connected to node j* . As

$$\frac{\partial a_j}{\partial w_{i \rightarrow j}} = \frac{\partial}{\partial w_{i \rightarrow j}} \left(\sum_k w_{k \rightarrow j} z_k \right) = z_i$$

we can write

$$\frac{\partial E_p(\mathbf{w})}{\partial w_{i \rightarrow j}} = \delta_j z_i$$

where we've defined

$$\delta_j = \frac{\partial E_p(\mathbf{w})}{\partial a_j}.$$

Backpropagation: the general case

So we now need to calculate the values for δ_j . When j is the *output node*—that is, the one producing the output $y = h(\mathbf{w}; \mathbf{x}_p)$ of the network—this is easy as $z_j = y$ and

$$\begin{aligned}\delta_j &= \frac{\partial E_p(\mathbf{w})}{\partial a_j} \\ &= \frac{\partial E_p(\mathbf{w})}{\partial y} \frac{\partial y}{\partial a_j} \\ &= \frac{\partial E_p(\mathbf{w})}{\partial y} \sigma'(a_j)\end{aligned}$$

using the fact that $y = \sigma(a_j)$. *The first term is in general easy to calculate for a given E as the error is generally just a measure of the distance between y and the label y_p in the training sequence.*

Example: when

$$E_p(\mathbf{w}) = (y - y_p)^2$$

we have

$$\begin{aligned}\frac{\partial E_p(\mathbf{w})}{\partial y} &= 2(y - y_p) \\ &= 2(h(\mathbf{w}; \mathbf{x}_p) - y_p).\end{aligned}$$

Backpropagation: the general case

When j is *not an output node* we need something different:

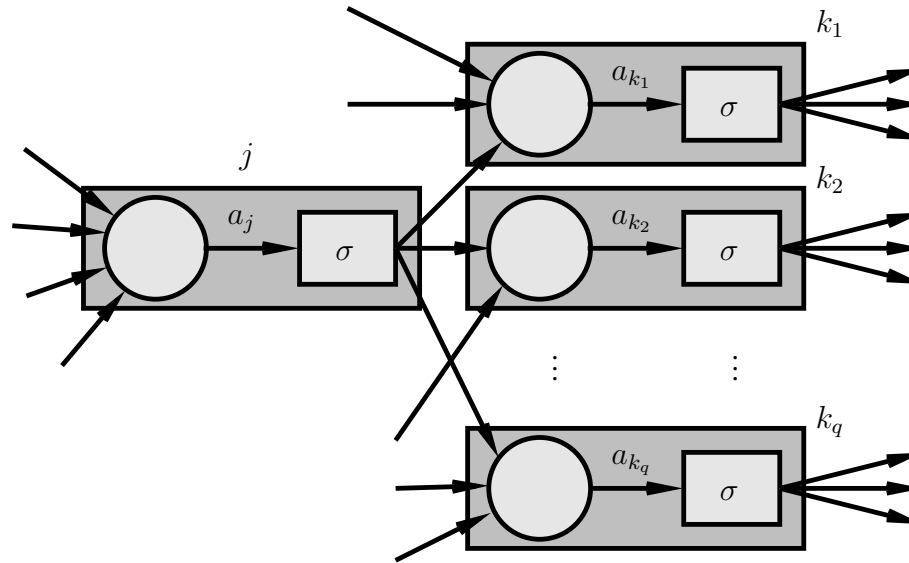

We're interested in

$$\delta_j = \frac{\partial E_p(\mathbf{w})}{\partial a_j}$$

Altering a_j can affect *several other nodes* k_1, k_2, \dots, k_q each of which can in turn affect $E_p(\mathbf{w})$.

Backpropagation: the general case

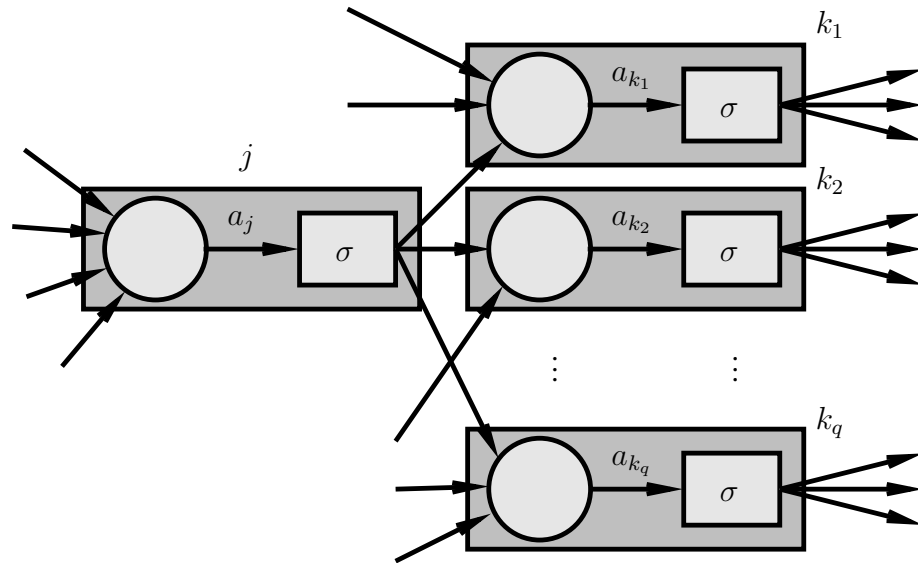

We have

$$\delta_j = \frac{\partial E_p(\mathbf{w})}{\partial a_j} = \sum_{k \in \{k_1, k_2, \dots, k_q\}} \frac{\partial E_p(\mathbf{w})}{\partial a_k} \frac{\partial a_k}{\partial a_j} = \sum_{k \in \{k_1, k_2, \dots, k_q\}} \delta_k \frac{\partial a_k}{\partial a_j}$$

where k_1, k_2, \dots, k_q are the nodes to which node j sends a connection.

Backpropagation: the general case

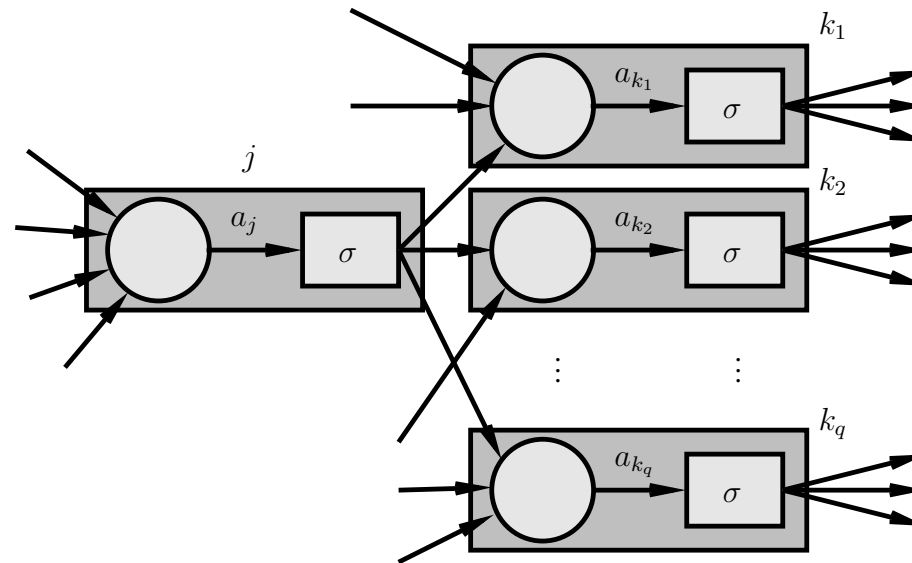

Because we know how to compute δ_j for the output node we can work backwards computing further δ values.

We will always know all the values δ_k for nodes ahead of where we are.

Hence the term *backpropagation*.

Backpropagation: the general case

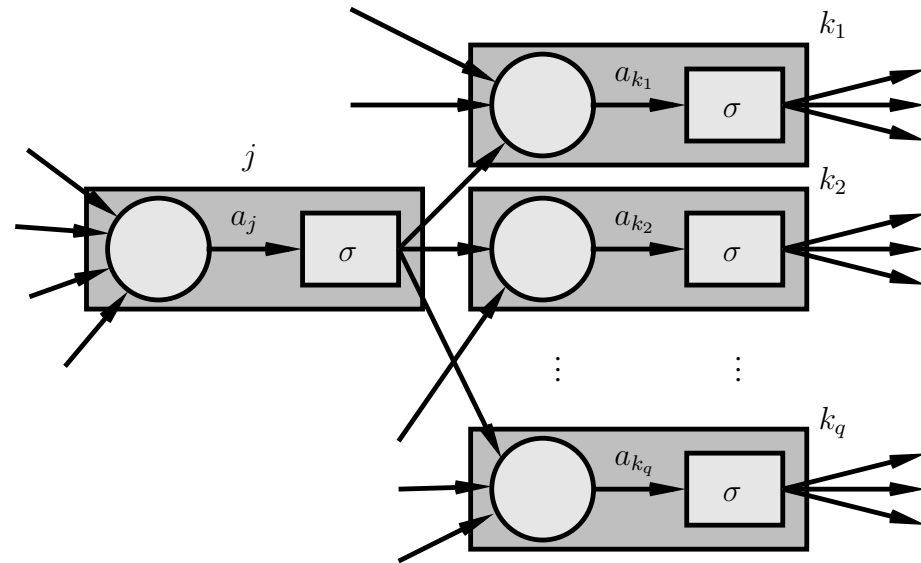

$$\frac{\partial a_k}{\partial a_j} = \frac{\partial}{\partial a_j} \left(\sum_i w_{i \rightarrow k} \sigma(a_i) \right) = w_{j \rightarrow k} \sigma'(a_j)$$

and

$$\delta_j = \sum_{k \in \{k_1, k_2, \dots, k_q\}} \delta_k w_{j \rightarrow k} \sigma'(a_j) = \sigma'(a_j) \sum_{k \in \{k_1, k_2, \dots, k_q\}} \delta_k w_{j \rightarrow k}.$$

Backpropagation: the general case

Summary: to calculate $\frac{\partial E_p(\mathbf{w})}{\partial \mathbf{w}}$ for the p th pattern:

1. *Forward propagation:* apply \mathbf{x}_p and calculate outputs *etc* for *all the nodes in the network*.
2. *Backpropagation 1:* for the *output node*

$$\frac{\partial E_p(\mathbf{w})}{\partial w_{i \rightarrow j}} = z_i \delta_j = z_i \sigma'(a_j) \frac{\partial E_p(\mathbf{w})}{\partial y}$$

where $y = h(\mathbf{w}; \mathbf{x}_p)$.

3. *Backpropagation 2:* For other nodes

$$\frac{\partial E_p(\mathbf{w})}{\partial w_{i \rightarrow j}} = z_i \sigma'(a_j) \sum_k \delta_k w_{j \rightarrow k}$$

where the δ_k were calculated at an earlier step.

Backpropagation: a specific example

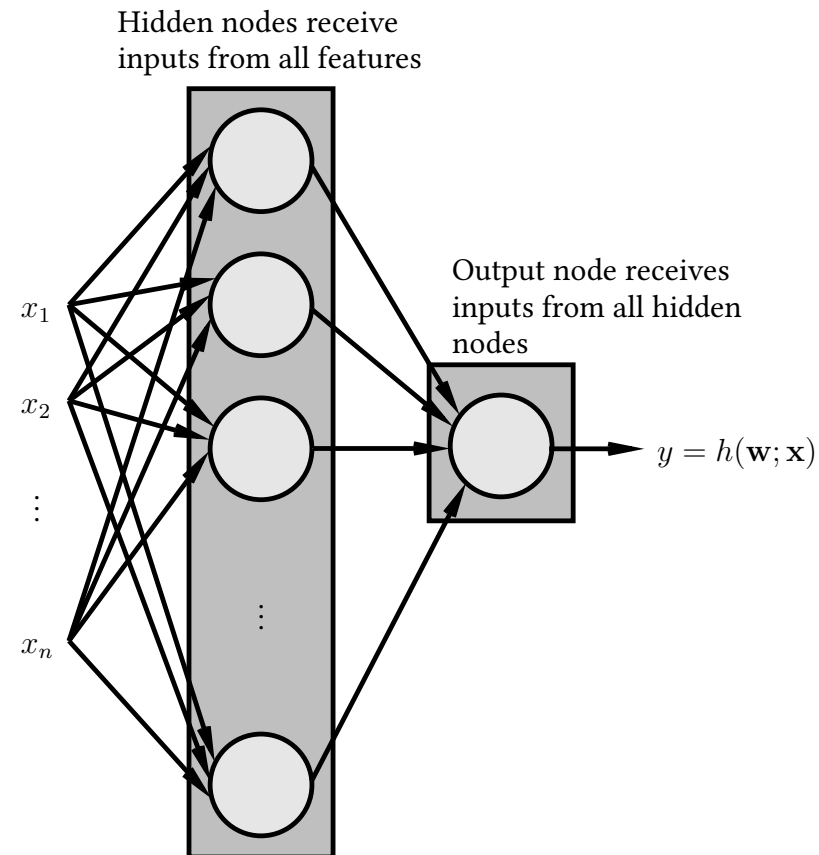

For the output: $\sigma(a) = a$. For the hidden nodes $\sigma(a) = \frac{1}{1+\exp(-a)}$.

Backpropagation: a specific example

For the output: $\sigma(a) = a$ so $\sigma'(a) = 1$.

For the hidden nodes:

$$\sigma(a) = \frac{1}{1 + \exp(-a)}$$

so

$$\sigma'(a) = \sigma(a) [1 - \sigma(a)].$$

We'll continue using the same definition for the error

$$E(\mathbf{w}) = \sum_{p=1}^m (y_p - h(\mathbf{w}; \mathbf{x}_p))^2$$

$$E_p(\mathbf{w}) = (y_p - h(\mathbf{w}; \mathbf{x}_p))^2.$$

Backpropagation: a specific example

For the output: the equation is

$$\frac{\partial E_p(\mathbf{w})}{\partial w_{i \rightarrow \text{output}}} = z_i \delta_{\text{output}} = z_i \sigma'(a_{\text{output}}) \frac{\partial E_p(\mathbf{w})}{\partial y}$$

where $y = h(\mathbf{w}; \mathbf{x}_p)$. So as

$$\begin{aligned} \frac{\partial E_p(\mathbf{w})}{\partial y} &= \frac{\partial}{\partial y} ((y_p - y)^2) \\ &= 2(y - y_p) \\ &= 2 [h(\mathbf{w}; \mathbf{x}_p) - y_p] \end{aligned}$$

and $\sigma'(a) = 1$ so

$$\delta_{\text{output}} = 2 [h(\mathbf{w}; \mathbf{x}_p) - y_p]$$

and

$$\frac{\partial E_p(\mathbf{w})}{\partial w_{i \rightarrow \text{output}}} = 2z_i (h(\mathbf{w}; \mathbf{x}_p) - y_p)$$

Backpropagation: a specific example

For the hidden nodes: the equation is

$$\frac{\partial E_p(\mathbf{w})}{\partial w_{i \rightarrow j}} = z_i \sigma'(a_j) \sum_k \delta_k w_{j \rightarrow k}.$$

However there is only one output so

$$\frac{\partial E_p(\mathbf{w})}{\partial w_{i \rightarrow j}} = z_i \sigma(a_j) [1 - \sigma(a_j)] \delta_{\text{output}} w_{j \rightarrow \text{output}}$$

and we know that

$$\delta_{\text{output}} = 2 [h(\mathbf{w}; \mathbf{x}_p) - y_p]$$

so

$$\begin{aligned} \frac{\partial E_p(\mathbf{w})}{\partial w_{i \rightarrow j}} &= 2 z_i \sigma(a_j) [1 - \sigma(a_j)] [h(\mathbf{w}; \mathbf{x}_p) - y_p] w_{j \rightarrow \text{output}} \\ &= 2 x_i z_j (1 - z_j) [h(\mathbf{w}; \mathbf{x}_p) - y_p] w_{j \rightarrow \text{output}}. \end{aligned}$$

Putting it all together

We can then use the derivatives in one of two basic ways:

Batch: (as described previously)

$$\frac{\partial E(\mathbf{w})}{\partial \mathbf{w}} = \sum_{p=1}^m \frac{\partial E_p(\mathbf{w})}{\partial \mathbf{w}}$$

then

$$\mathbf{w}_{t+1} = \mathbf{w}_t - \eta \left. \frac{\partial E(\mathbf{w})}{\partial \mathbf{w}} \right|_{\mathbf{w}_t} .$$

Sequential: using just one pattern at once

$$\mathbf{w}_{t+1} = \mathbf{w}_t - \eta \left. \frac{\partial E_p(\mathbf{w})}{\partial \mathbf{w}} \right|_{\mathbf{w}_t}$$

selecting patterns *in sequence or at random.*

Example: the parity problem revisited

As an example we show the result of training a network with:

- Two inputs.
- One output.
- One hidden layer containing 5 units.
- $\eta = 0.01$.
- All other details as above.

The problem is the parity problem. There are 40 noisy examples.

The sequential approach is used, with 1000 repetitions through the entire training sequence.

Example: the parity problem revisited

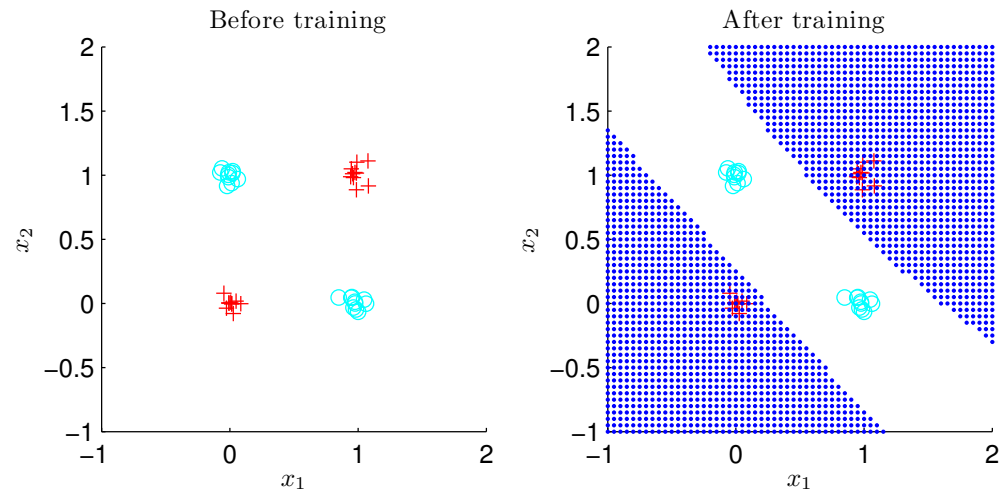

Example: the parity problem revisited

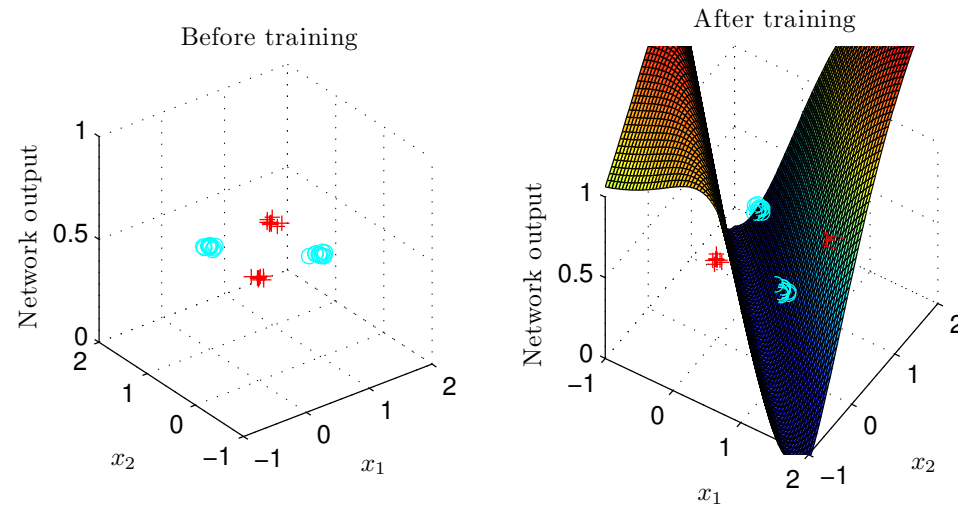

Example: the parity problem revisited

