

## Digital Hardware Labs - Introduction

Many materials are available on which to build prototype circuits. The material chosen will depend on the required life and use of the circuit. For laboratory use or other short-term applications where a permanent circuit is not needed and the operating frequency is below 10 MHz, solderless breadboards such as that used in the prototyping box shown below are suitable.

The prototyping box comprises:

- 3 breadboards on which your circuits will be constructed
- A 5 volt power supply required for the logic integrated circuits (chips)
- A variable frequency clock which operates in either manual or free running mode
- 8 switches, which can provide inputs to your circuit
- 2 push button switches (not debounced)
- A debounced push button switch
- Two 7-segment light emitting diode (LED) display
- A 10x7 LED array
- 8 user input LEDs
- A potentiometer

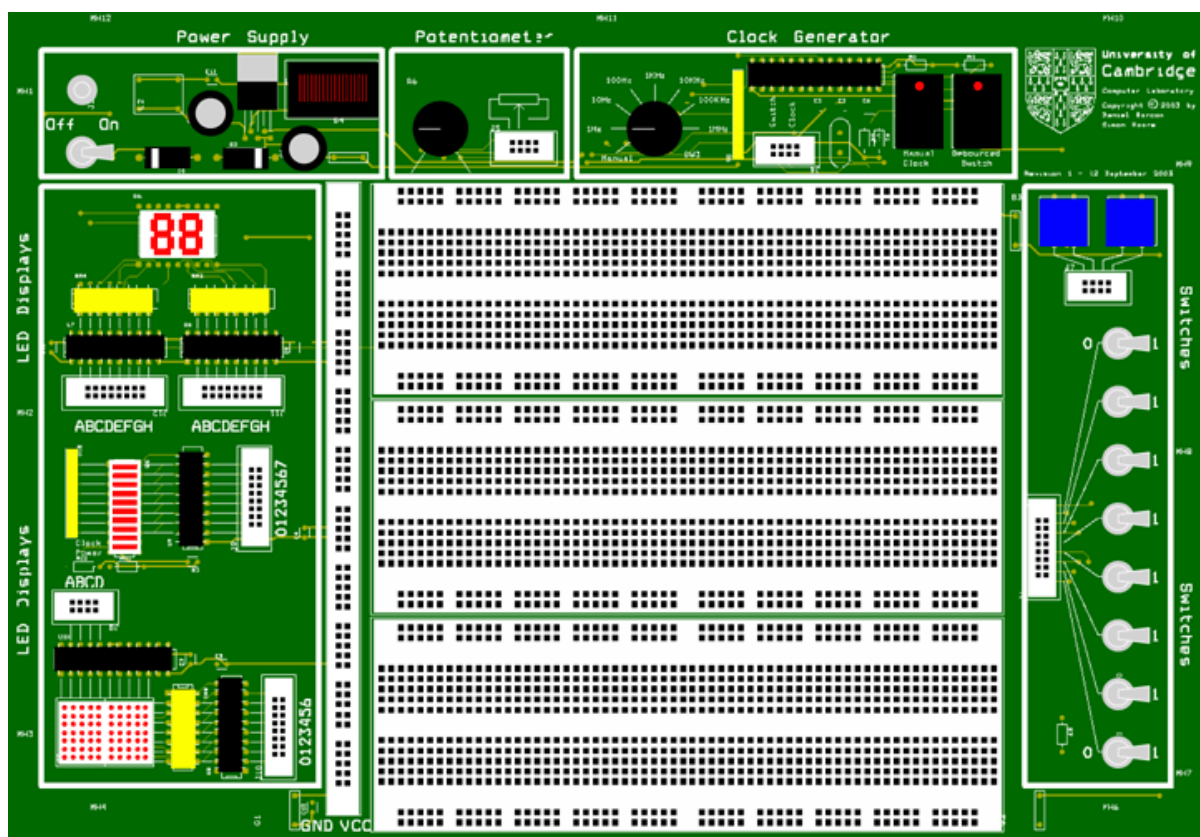

There are three banks of LEDs on the left hand side of the board for signal output:

- At the top there is a pair of 7-segment LED displays which are connected via PALs. The PALs have been configured to do binary to 7-segment hexadecimal character conversion. Inputs A to D provide the binary inputs.
- In the middle there is an LED bar graph. 8 of the LEDs are connected via a buffer. The other two indicate when the power is on and the state of the clock.

- At the bottom you will find an LED matrix. The column decoding is provided by a 4-to-16 line decoder (inputs A to D) and the row value is supplied via a buffer (inputs 0 to 6).

## Using the Breadboard

A breadboard has many strips of metal which run underneath the board. The metal strips are laid out as shown in red below, horizontally along the two lines at the top and bottom, and vertically to join six holes together in the central section.

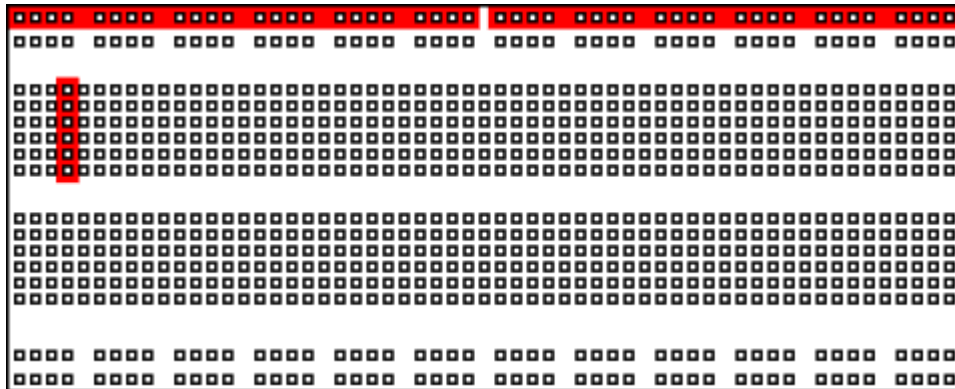

These strips connect the holes on the top of the board. This makes it easy to connect components together to build circuits. To use the breadboard, the legs of components are placed in the holes (the sockets). The holes are made so that they will hold the component in place. Each hole is connected to one of the metal strips running underneath the board.

The long top and bottom row of holes are usually used for power supply connections. The rest of the circuit is built by placing components and connecting them together with jumper wires. Chips can be placed in the middle of the board so that half the legs are on one side of the middle line and half are on the other side. A completed circuit might look like the following.

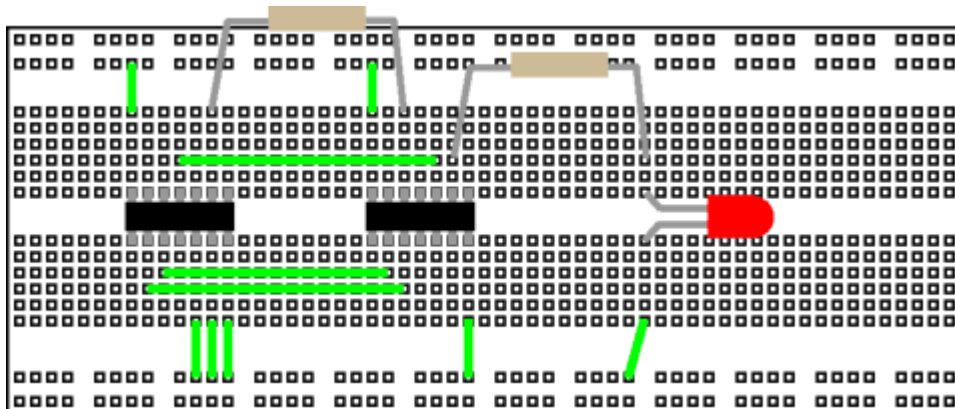

Careful planning of the circuit layout simplifies wiring, minimizes errors and makes debugging easier. Try to arrange the circuit for a logical signal flow, usually inputs on the left and outputs on the right. This helps anyone looking at the board to find easily sections of the circuit and trace signals through it. Wherever possible, all ICs should be pointed in the same direction to reduce the chance of one being put in backwards. This also makes it easier to keep track of pin numbers when wiring and debugging. Colour coded wiring is an easy way to reduce wiring errors and aid the process. If possible, build and test one

section of the circuit at a time to simplify debugging before connecting the sections together. Keep connecting wires as short as possible and route them around ICs so that a defective IC can be replaced without removing and often incorrectly replacing the wires. While all this may seem laborious, the time spent in careful construction and checking is well repaid by having more circuits work first time.

The pin outs of all the ICs used in the hardware labs are available as a booklet in the lab. Never take the pin out of an IC for granted! Below are two similar chips: the 7400 and 7402, are quad NAND and quad NOR gates respectively. Note the different pin out.

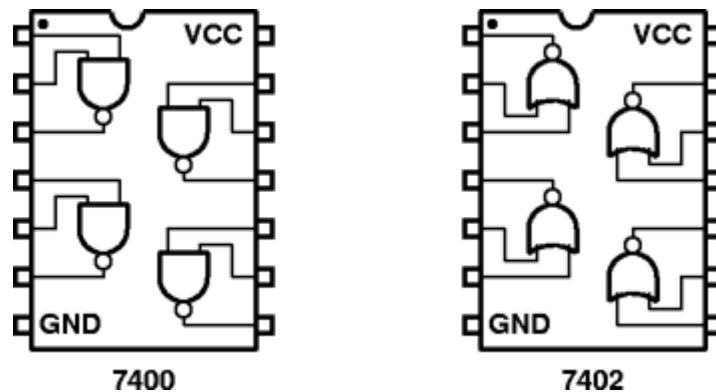

More details concerning the chips you will be using are available in the lab booklet and also on the course web page.

### Common Ticking Criteria

All of the workshops should be written up in full in the style of a laboratory log book. You may use an actual log book or else loose sheets with page numbers. From your notes it should be possible for somebody else to be able to reproduce your work. This is good scientific practise. When an exercise is complete and written up, including answers to the questions, the final page will be signed by a demonstrator and a tick entered in the tick sheet.

We recommend that you draw out circuits in your log book before wiring them up. Put pin numbers for the connections to each chip.

**VERY IMPORTANT: you need to hand in this assessed exercise as part of your portfolio of work at the end of the year (see the Head of Department's Notice), SO YOU MUST KEEP YOUR WORK!**

### Appendix 1 – Resistor Colour Code

Resistors are normally coded with coloured bands to enable quick identification of their value. The colour code specifies the value of the resistor, in ohms, and the maximum deviation from the stated value (the tolerance). Most resistors have a manufacturer's tolerance with is adequate for most electronic applications.

#### Interpreting the Colour Code

The four colour code bands are at one end of the component. Counting from the end, the first three (or sometimes four) bands give the resistance value and the last the tolerance.

The significance of the colours is shown in the table below:

First 3 (or 4) bands		Tolerance band	
Black	0	Brown	1%
Brown	1	Red	2%
Red	2	Gold	5%
Orange	3	Silver	10%
Yellow	4	No band	20%
Green	5		
Blue	6		
Violet	7		
Grey	8		
White	9		

### Reading the value (three band)

The first two bands are used to specify the first two digits of the resistor's value. The third gives the number of noughts to be added. Thus in this example, yellow and violet give the first two digits as 4 and 7 and the number of zeros is 3 (orange) giving a value of 47000 ohms.

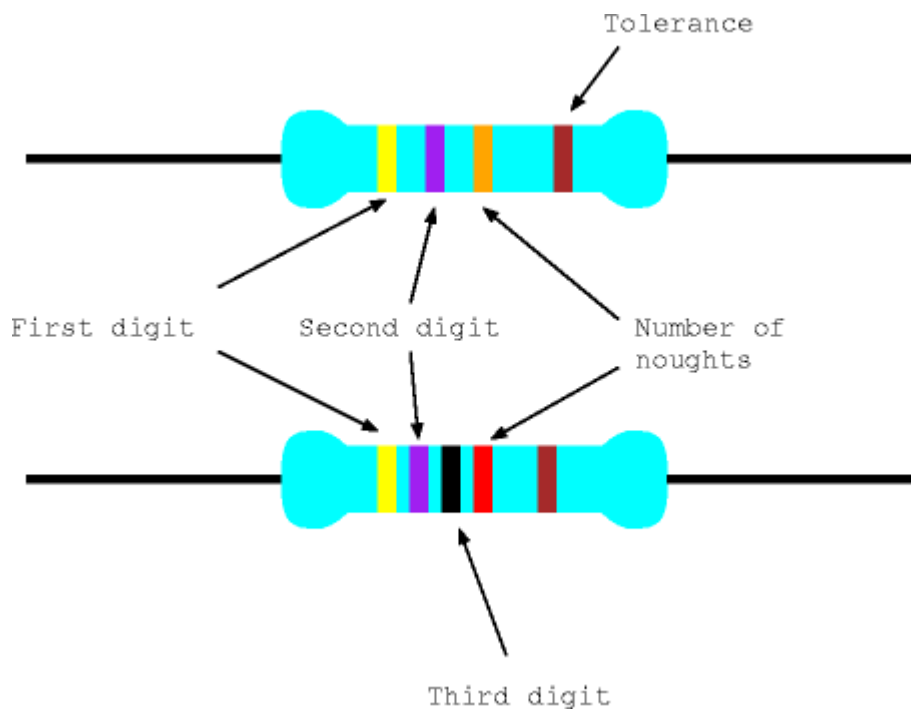

### Four Band Resistors

More modern resistors use four bands to specify the resistance, the first three giving the three most significant digits and the fourth the number of zeros. Yellow, violet, black, red decodes as 4, 7, 0, 00 i.e., 47000 ohms.