

Network Attack and Defence

Simplicity is the ultimate sophistication.

– LEONARDO DA VINCI

There's no security here – keep moving!

– RICHARD CLAYTON

21.1 Introduction

In this chapter I'm going to try to draw together the network aspects of security in a coherent framework. This is not straightforward as much of network security is practical engineering; a purist from computer science might see the field as one bodge piled on top of another. And network security may not be that important to many developers: if you write apps for Androids and iPhones that talk to services on AWS or Azure, then you can leave much of the worry to Amazon or Microsoft.

But many organisations need to pay attention to network security, and there are some visible strategic trends. For twenty years, it was accepted that firms would have a trusted internal network or intranet, protected from the Internet by firewalls; while taken to extremes by defence and intelligence organisations with classified internal networks, milder versions were seen as best practice by most normal firms. And some industries have no viable alternatives. For example, the protocols used in industrial control systems – DNP3 and Modbus – don't support encryption or authentication, as they evolved in the days of leased lines and private radio links. By the late 1990s, control systems engineers were attaching sensors and actuators to IP networks, as they were cheaper – and then realising that anyone in the world who knew a sensor's IP address could read it, and anyone who knew an actuator's IP address could activate it. This led to the growth of specialist firms who sell firewalls that understand these protocols; energy companies have thousands of them.

A typical electricity substation might have two hundred devices from a multiplicity of vendors, on a LAN where performance is critical, so retrofitting crypto is impractical; but it has one connection to the outside world, so that's where you have to put the protection. This is known as *re-perimeterization*. The same approach is taken with vehicles, where the internal CANBUS cannot be protected, so the radio interfaces with the outside world have to be.

But in many firms the trend is firmly in the other direction, towards *deperimeterisation*. One thought leader is Google, promoting an architecture without firewalls that it calls a *zero-trust security model*: "By shifting access controls from the network perimeter to individual users and devices, BeyondCorp allows employees, contractors, and other users to work more securely from virtually any location without the need for a traditional VPN." Google's experience is that the move to mobile and cloud technology is making network perimeters ever harder to define, let alone police, and if a firm's large enough that some internal compromise is inevitable anyway then the perimeter is the wrong place to put the primary protection [1988]. There are still some perimeter defences, most notably against service-denial attacks, but internal networks are otherwise unprivileged and the emphasis is on tight authentication and authorisation of users and devices: each service has an Internet-facing access proxy. One might see this as a per-service firewall rather than a per-building firewall, but there is quite a lot more to it with tiers of sensitivity, a device inventory service and an access control engine [1481]. You also need really good HR data, so you can tie staff and contractors to devices and the services they're allowed to use. Much the same architecture is being adopted by other firms operating large-scale data centres, and zero-trust security is now the subject of draft standards activity by NIST [1621]. It will no doubt get a boost from the pandemic because of the huge increase in home working.

Other organisations may take a hybrid approach. The university where I work, for example, has some defences at the perimeter but largely lets departments do our own thing; a computer science department has quite different requirements from a humanities department or the finance office.

In order to explore the options and constraints, I'm first going to discuss networking protocols such as BGP, DNS and SMTP and the service-denial attacks that can result from their abuse. I'll then take a closer look at malware, and then at defensive technologies such as filtering and intrusion detection and how defenders can coordinate them. I'll then survey the limitations of widely-used crypto protocols such as TLS, SSH and IPsec, and the particularly tricky role of certification authorities. Finally I'll return to network architecture. Many issues are complex and interlinked, with some significant trade-offs. For example, various kinds of end-to-end crypto can bring benefits – particularly against bulk surveillance – but can get in the way of the surveillance we want for network security.

This chapter will deal with fixed networks, and I'll discuss what's different about mobile networks in the following chapter.

21.2 Network protocols and service denial

I'm going to assume some familiarity with basic network protocols. The telegraphic summary is as follows. The *Internet Protocol* (IP) is a stateless protocol that transfers packet data from one machine to another; IP version 4 uses 32-bit *IP addresses*, often written as four decimal numbers in the range 0–255, such as 172.16.8.93. ISPs are migrating to IP version 6, as the 4 billion possible IPv4 addresses are just about allocated; IPv6 uses 128-bit addresses. Some 10–15% of traffic is now IPv6; in many countries a new broadband subscription will get you an IPv6 address which works for all normal consumer purposes.

Local networks mostly use ethernet, in which devices have unique ethernet addresses (also called MAC addresses) that are mapped to IPv4 addresses using the *address resolution protocol* (ARP). The *Dynamic Host Configuration Protocol* (DHCP) is used to allocate IP addresses to machines as needed and to ensure that each IP address is unique. *Network address translation* (NAT) also enables multiple devices on a network to use the same Internet-facing IP address, typically with different port numbers; this is used by most mobile network operators and many ISPs. So if you want to track down a machine that has done something wicked, you will often have to get the logs that map MAC addresses of devices to IP addresses. There may be more than one log, and lots can go wrong – such as wrong timestamps, and failure to understand time zones.

One of the most basic concerns is the prevention and mitigation of *denial-of-service* (DoS) attacks. These have a number of flavours. An opponent can try to steal some of your IP address space, or one or more of your domains, in order to send spam; even when you get it back, you may find it's been extensively blacklisted. An opponent can send you huge floods of traffic from a botnet of many compromised machines; a *distributed denial-of-service* (DDoS) attack. They can abuse various online services such as DNS to send you floods of packet traffic. Let's work through these in turn.

21.2.1 BGP security

The Internet is an interconnected network of networks: its components are *Autonomous Systems* (ASes) such as ISPs, telcos and large organisations, each of which controls a range of IP addresses. The glue that holds them together, the core routing protocol of the Internet, is the *Border Gateway Protocol* (BGP).

Routers – the specialized computers that switch packets on networks – use BGP to exchange information about what routes are available to get to particular blocks of IP addresses, and to maintain routing tables so they can select efficient routes to use. ASes can route traffic to other ASes by buying service from large transit providers but typically cut the costs of this by peering with each other at a local *Internet interchange* (IX), of which most countries have at least one and large countries may have several.

Internet interconnectivity is a complex ecosystem with many interdependent layers. Its open and decentralised organisation has been essential to the success and resilience of the Internet, which has meant that the effects of natural disasters such as Hurricane Katrina and terrorist attacks such as 9/11 have been limited in time and space, as have assorted technical failures. However, the Internet is slowly becoming more centralised, as a result of the consolidation of Tier-1 providers, and is vulnerable to common-mode failures (such as electric power cuts) as well as to disruptive attacks.

About the worst attack we can reasonably foresee would involve an attacker planting malware on thousands of routers so they advertise large numbers of false routes, clogging the routing tables and tearing up the routing fabric. There have been several warnings already in the form of incidents and accidents. In 2008, YouTube became inaccessible for a few hours after the government of Pakistan tried to censor it locally by announcing false routes to it, which propagated globally; and in 2010 China Telecom advertised over 100,000 invalid routes, hijacking 15% of Internet addresses for 18 minutes. Some people ascribed that to accident, while others suggested that China had been testing a ‘cyber-nuke’, some of whose fallout escaped. Most routers now accept only a limited number of routes from each of their peers, be it a few dozen or a few hundred; so large-scale disruption would require thousands of subverted routers. Both China and (more recently) Russia have been working on making the Internet in their countries separable, so that major disruptive attacks could in theory be launched without inflicting unacceptable collateral damage on local services and facilities. There have been reports of BGP hijacking being used by China for intelligence collection; for example, traffic from Canada to Korean government websites was routed via China from February 2016 for six months [533]. There has also been criminal misuse, ranging from the hijacking of IP address space by spammers, to an eight-figure ad fraud in 2018 whose perpetrators hid in address space stolen from the US Air Force [792]. Finally, there is a growing political tussle in 2019–20 about whether Huawei should be allowed to sell routers at scale (or at all) in countries allied to the USA.

Taking a step backward, the resilience of the Internet is hard to define and to measure; it is in tension with efficiency and may be decreasing as a small number of very large networks come to dominate. These range from the dominant transit provider, Lumen (the company changed its name from Level 3 to Lumen), to content delivery networks (CDNs) operated by Google, Akamai,

Cloudflare and others. There are many complex interactions between resilience and efficiency, reachability and congestion, traffic prioritisation and commercial sensitivity, complexity and scale. There's no mechanism to check the validity of routing information distributed via BGP. The pervasive mistrust between ISPs and governments makes regulation difficult. The lack of good information about how the system works makes rational discussion difficult too. Resilience has so far depended on surplus capacity and rapid growth, but that cannot continue for ever. In 2011 colleagues and I wrote a major report for the European Network and Information Security Agency that explores these issues in detail [1910].

The main technical BGP security mechanism at present is the *Resource Public Key Infrastructure* (RPKI), which enables registries to certify that "Autonomous system X announces IP address range Y". This will not prevent capable attackers, as a malicious route announcement will just have the right AS at the end of the route following the attacker's in the middle; but it detects the fat-finger mistakes that cause most of the outages. Whether it will make an already fragile BGP system more robust to have lots of certificates in it remains to be seen; when RIPE's certificate expired in February 2020 there was a short outage until it was fixed. For the future, people are working on Peerlock, whereby the main ASes at an interchange share information about what routes they will and won't announce; this has the prospect of bringing enough local benefit to exchange members for it to be practically deployable.

21.2.2 DNS security

The *Domain Name System* (DNS) allows human-readable names such as `ross-anderson.com` to be mapped to IP addresses of either kind; there's a hierarchy of DNS servers that do this, ranging from several hundred top-level servers down through machines at ISPs and on local networks, which cache DNS records for performance and reliability. It does occasionally get attacked: the Mirai botnet attacked DynDNS in October 2016, taking out Twitter on the US eastern seaboard for five hours. But DNS has become a massively distributed system with a lot of very fast machines connected to very high-capacity networks, so service denial attacks on it are rare.

Hijacking does occur from time to time, and at various levels. Some states intercept and redirect DNS queries as a means of censorship; some ISPs have done so, as a means of replacing ads in web pages with ads from which they get a cut; and a DNS server at an ISP may be hacked to drive clients to a wicked website. This is known as *pharming*, and in a variant called *drive-by pharming*, the crooks lure you to a web page containing JavaScript that changes your home router's DNS server from the one at your ISP to one under their control [1819]. Next time you try to go to `www.citibank.com`, you may be directed to a phishing site that emulates it. That's one reason to change the default

password on your home router – even if it’s only accessible from inside your network.

In order to prevent DNS hijacking, DNSSEC adds digital signatures to DNS name records. By verifying such a signature you can check that the record came from the authoritative server and was not altered en route. Uptake is patchy: all US government domains in `.gov` are supposed to be signed, and most domains in Sweden are signed, as the registrar made signed domains cheaper. However, some major firms like Google don’t sign their DNS records out of concern that cryptography makes systems more fragile; if anything goes wrong, you can just disappear. Other firms avoid DNSSEC because they don’t want competitors to ‘walk the zone’ and enumerate all their subdomains; the NSEC3 extension enables firms to avoid this using hashes, but many firms (or their service providers) have not yet built the infrastructure.

Another problem with DNSSEC is that it gets abused in denial-of-service attacks. A common technique is that Alice attacks Bob by sending Charlie a message saying, “Hey, can you tell me the very large answer to this short question? Yours, Bob!” As signed DNS records are a lot larger, a DDoS-for-hire service can use DNSSEC as an amplifier, Alice can send packets that purport to come from Bob’s IP address to many DNS servers, which then bombard the target with replies. (Cheeky criminals use the FBI as Charlie, as `fbi.gov` has two nice big keys.)

The controversial issue in 2020 is *DNS-over-https* (DoH). The main browser maintainers, Chrome and Mozilla, propose that rather than sending DNS traffic in the clear, it will go encrypted over https to a DoH resolver. This is claimed to be good for privacy, as your ISP will have less information about your browsing (but unless you use Tor, it will still have plenty). The downside is that many enterprise security products monitor DNS to detect abuse. If malware compromises a machine in your fleet, you may spot it when it tries to contact a command-and-control server, so enterprises buy threat intelligence feeds and monitor the domain names (and IP addresses) blacklisted on them. Sysadmins also like to monitor for DNS hijacking, and to block certain domains as inappropriate for work. DoH will make all this harder, and is questionable architecture as running a core network service over an application means it’s ‘not the Internet any more’ [430]. On the commercial side, DoH may entrench Google’s grip on the advertising market, while causing problems for content delivery networks like Akamai and Cloudflare over routing, load balancing and so on. It will also stop ISPs transcoding videos for mobile users to save bandwidth. Experts would have preferred to run DNS over TLS instead.

21.2.3 UDP, TCP, SYN floods and SYN reflection

On wide-area networks, most data move between machines using either the *User Datagram Protocol* (UDP), which is connectionless, or the *Transmission*

Control Protocol (TCP), which sets up persistent connections between endpoints. Let's start with the 3-way handshake used by Alice to initiate a TCP connection to Bob and set up sequence numbers for subsequent packet traffic (see Figure 21.1).

```
A → B:    SYN; my number is X
B → A:    CK; now X + 1
          SYN; my number is Y
A → B:    ACK; now Y + 1
          (start talking)
```

Figure 21.1: TCP/IP handshake

This protocol has been exploited in many ways. The classic service-denial attack is the *SYN flood*. Alice simply sends a lot of SYN packets and never acknowledges any of the replies. Bob accumulates more records of SYN packets than his software can handle. This was used in one of the first distributed denial-of-service attacks that brought down Panix, a New York ISP, for several days in 1996.

The technical fix was the 'SYNcookie': rather than keeping a copy of the incoming SYN packet, *B* simply sends out as *Y* an encrypted version of *X*. That way, Bob doesn't have to retain a lot of state about half-open sessions. Despite this, SYN floods persisted, albeit at a declining rate, for many years. The general principle is that when you're designing a protocol anyone can invoke, don't let malicious users force honest ones to do work.

The more common attack now is *SYN reflection*. Alice sends Bob a packet that purports to come from Charlie. Bob replies to Charlie, and in practice systems send up to five ACKs in response to each SYN as a robustness measure, so there's still a useful amplification effect.

21.2.4 Other amplifiers

Many other protocols have been used in service-denial attacks than DNS and TCP [1505]. An early favourite was *smurfing*; this exploited the *Internet control message protocol* (ICMP), which enables users to send an echo packet to a remote host to check whether it's alive. If Alice sent an ICMP packet purporting to come from Bob to a broadcast address, all the machines on the subnet would send him a response. The protocol was changed so that broadcast addresses didn't reply. The bad guys changed to use protocols such as NTP and DNS for which amplifiers could still be found.

More thorough fixes for attacks based on packet amplification were to follow. Most of the available amplifiers use UDP packets, including ICMP and NNTP but not SYN reflection; so starting from the mid-2000s, broadband ISPs started filtering out UDP packets with forged source addresses. Microsoft also

changed their network stack to make it much harder for an infected machine to send a packet with a spoofed IP address; you now need to hack the operating system, not just any old application. So attacks that exploit UDP packet amplifiers have to be run from servers in hosting centres. In the late 2010s, such attacks have become increasingly the preserve of DDoS-for-hire operators, against whom the most effective countermeasure has been to raid them and arrest them.

21.2.5 Other denial-of-service attacks

As the clever ways of creating service-denial attacks have been closed off one by one, the bad guys have turned increasingly to brute force, by sending floods of packets from infected machines. The first *distributed denial-of-service* (DDoS) attack may have been the Morris worm in the 1980s, and the first deliberate one in the 1990s with the attack already mentioned on Panix. Nowadays, botnets are assembled using all sorts of vulnerabilities, and underground markets let some people specialise in hacking machines and selling them to others who extract value in various ways. Since 2016, the machines most used for DDoS have been IoT devices such as CCTV cameras, which are now connected in large numbers to home WiFi networks with reasonable bandwidth, but which tend to have known default passwords – and are often incapable of being patched. The Mirai botnet appeared in 2016 to exploit this opportunity, and there have been over a thousand variants of it since (its source code got posted to Hackforums).

There are various motives for service-denial attacks. Most are launched by schoolkids – typically gamers who want to take down an opposing crew's teamspeak server. There has for some years been a black market in DDoS-for-hire, which the authorities in the USA and elsewhere have been trying to close down. There have been some incidents of blackmail (e.g., of online bookmakers), and a growing use of the technique for suppressing political opponents – starting perhaps with attacks on the servers of an opposition party in Kyrgyzstan, even when these were relocated to North America [1616]. We discussed their use in conflict by states in Chapter 2.

That said, one mustn't forget online activism. If a hundred thousand people send email to the White House protesting against some policy or other, is this a DDoS attack? Protesters should not be treated as felons; but protest can easily shade over into abuse, and drawing legislative distinctions can be hard.

21.2.6 Email – from spies to spammers

The SMTP standard for email has particular issues around the prevention of bulk interception, and the prevention of bulk unwanted mail.

Email is by default neither encrypted nor authenticated, and was for decades available to anyone who could either monitor the network or access mail servers. It was possible to use programs such as PGP/GPG to encrypt mail, but this never caught on outside small communities. First, such programs can be a pain to use, and second, there are strong network effects: there's no point in using email encryption if none of your friends do. What's more, if only a small group of people use encryption, this may just bring them to the attention of the authorities; subversive groups, spies and so on really need anonymity rather than just confidentiality, as we discussed in section 20.4. So PGP/GPG tends to be used by specialists, such as sysadmins and anti-virus researchers.

There are two main countermeasures to bulk interception. First, most mail servers use `starttls` to set up encrypted communications with other mail servers as they exchange mail, especially since the Snowden revelations. Encrypted exchanges can be blocked by man-in-the-middle attacks, and these have been reported in some less-democratic countries. The current countermeasure to such attacks, *MTA Strict Transport Security* (MTA-STS), is supported by Microsoft, Google and Yahoo [1222]: it allows mail service providers to specify that mail should only be delivered to them via a TLS session authenticated by a proper certificate which you download from their website. This prevents downgrade or interception attacks on email to and from the big boys, and also allows opportunistic, trust-on-first-use encryption to other servers. MTA-STS has generally supplanted an earlier standard, *DNS-based Authentication of Named Entities* (DANE) which put a TLS certificate for `starttls` in the mail server's DNS record¹.

The second countermeasure is that some 95% of personal email accounts nowadays are at the big five webmail providers, and many corporates use them too. In this case, the confidentiality of email is assured by TLS, fortified with certificate pinning and certificate transparency which we'll discuss later. But although bulk access may be blocked, webmail is subject to warranted access, just like other services that corporates outsource.

Bulk unwanted mail, or spam, has two components. The first is entirely legal but unwanted marketing communication. As marketers can make it tiresome to opt out, users find it more convenient to press the 'report spam' button once an offer or supplier is no longer of interest.

The second consists of floods of generally unwanted traffic sent out for the most part by botnets, and often with clear criminal intent. This is in some respects similar to a DDoS attack: just as DDoS bots may forge IP addresses, spam bots may forge the sender's email address. This is fought by the big providers with four main mechanisms.

¹DANE is still widely used in Germany, but Google refused to use it as it depends on DNSSEC, which Google considers to be insufficiently dependable.

1. *Domain Keys Identified Mail* (DKIM) ties email to the sending domain by signing it using a signature key whose public verification key is kept in the sending domain's DNS record. The signed material is selected to identify the message unambiguously despite the additions to headers that occur during transit, but to stop the bad guys adding an extra "From: PayPal" header. Mail that hasn't been altered too much can be forwarded. There's a replay attack in that the spammer sends his spam through Gmail, which signs it, and then forwards it afterwards; so mail servers cache DKIM signatures and discard mail carrying a signature that's already been seen a few times.
2. *Sender Policy Framework* (SPF) is similar but ties mail to the source IP address. Again, this is verifiable against a key in the domain DNS record. SPF doesn't allow mail forwarding; mailing list servers are supposed to use a related protocol called *Authenticated Received Chain* (ARC) to re-sign mail they forward.
3. A domain's DNS can also contain a *Domain-based Message Authentication, Reporting and Conformance* (DMARC) record, which enables its owner to recommend what a recipient should do with email that appears to come from the owner's domain but which fails authentication using both DKIM and SPF.
4. Machine-learning systems are used to filter mail against authentication results and other criteria, and take much of their ground truth from whether users report mail as spam. This is made more complicated by user preferences for marketing material, which vary by user and over time.

The illegal segment of spam is now a highly specialised business, run by several large gangs. Its statistics have been 'lumpy' since the mid-2000s, and this has been getting more pronounced. As of 2020, the gangs typically steal IP address space using malicious BGP route announcements, register thousands of domains, and send a few hundred spams from each before the machine-learning filters kick in and block them.

21.3 The malware menagerie – Trojans, worms and RATs

The first examples of malicious code were *Trojan Horses* – named after the horse the Greeks left for the Trojans, supposedly as a gift but which contained soldiers who opened the gates of Troy to the Greek army [1131]. There have been religious wars over nomenclature for years, which is why many people prefer to just use the term *malware*. My usage is that a Trojan is a program

that does something malicious (such as capturing passwords) when run by an unsuspecting user. A *worm* is a malicious program that replicates itself on other systems, while one that does so by hooking itself into the code of other programs is a *virus*. A *remote access Trojan* (RAT) is software that may or may not run as root but that enables a remote party to access the device it runs on, while a *rootkit* is software installed as root on a device and that stealthily enables a third party to control it. *Potentially unwanted software* (PUS) may have been installed openly or by deception, but does something the user doesn't want (if they understand it at all).

These categories are not mutually exclusive and the boundaries can be context dependent. For example, stalkerware – software that enables one person to track another's mobile phone location and use – falls into different categories depending on whether it was installed covertly, or by a controlling man bullying his partner, or by a court ordering it as a condition of bail. Even stealthy malware isn't always illegal as it can be used by law-enforcement agencies to turn suspects' phones and laptops into listening devices, as well as by fraudsters to operate bank accounts by remote control².

Malware generally uses stealth techniques to hide, but eventually it's identified and tools to remove it are written. There's a whole ecosystem around malware: malware writers, botnets of infected machines, and a range of security firms offering everything from threat intelligence to antivirus software. (There are even firms selling malware – particularly to government agencies.) And in addition to the formal economy, there's an underground economy of cybercrooks selling everything from banking Trojans to DDoS-for-hire services.

21.3.1 Early history of malware

In the early 1960s, machines were slow and their CPU cycles were rationed – with students often at the tail of the queue. Students invented tricks such as writing computer games with a Trojan inside to check if the program is running as root, and if so to create a privileged account with a known password. By the 1970s, time-sharing systems at universities were the target of more and more pranks involving Trojans. All sorts of tricks were developed. In 1978, John Shoch and Jon Hupp of Xerox PARC wrote a program they called a *worm*, which replicated itself across a network looking for idle processors so it could assign them tasks [1727].

In 1984, Ken Thompson gave a classic paper “Reflections On Trusting Trust”, when he accepted a Turing award, the top prize in computer science. He

²At the other end of the spectrum, some antivirus products behave like malware in various ways, including being very hard to remove after a ‘free trial’, or by introducing insecurities. In December 2019, one brand of AV software was removed by Chrome, Firefox and Opera for exfiltrating too much personal information [354].

showed that even if the source code for a system were carefully inspected and known to be free of vulnerabilities, a trapdoor could still be inserted [1887]. His trick was to build the trapdoor into the compiler. If this recognized that it was compiling the login program, it would insert a master password that would work on any account³. Of course, someone might examine the source code for the compiler, and then compile it again from scratch. So if the compiler recognizes that it's compiling itself, it inserts the vulnerability anyway, even if it's not present in the source. So even if you can buy a system with verifiably secure hardware, operating system and applications, the compiler binary can still contain a Trojan. The moral is that in order to trust a system completely, it is not enough to build all of it, in the sense that software engineers use the word 'build', namely compiling it from source code. You have to create all of it, including the tool chain, and the hardware too.

Malware next became mobile. The first-ever computer virus in the wild was written for the Apple II by a 9th-grader in 1981 [1218]. In 1984 Fred Cohen did a PhD on the topic; his experiments with different operating systems showed how code could propagate itself from one machine to another, and as I mentioned in Section 9.6.4, from one compartment of a multilevel system to another. Within about three years we started to see the first real live viruses in the wild: PC viruses which spread when users shared programs on diskettes or via bulletin boards⁴.

One early innovation was the 'Christma' virus, which spread round IBM mainframes in December 1987. It was a program written in the mainframe command language REXX that had a header saying 'Don't read me, EXEC me' and code that, if executed, drew a Christmas tree on the screen – then sent itself to everyone in the user's contacts file. It was written as a prank, rather than out of malice; and by using the network (IBM's BITNET) to spread, and inviting users to run it, it was ahead of its time.

21.3.2 The Internet worm

The press and public became aware of malware in November 1988 with the Internet worm. This was a program written by Robert Morris Jr that exploited a number of vulnerabilities to spread from one machine to another in November 1988 [617]. It tried 432 common passwords in a guessing attack, looked for any machines trusted by the machine it infected, and also tried to exploit vulnerabilities in Unix (including the `fingerd` bug mentioned in

³This developed an idea first floated by Paul Karger and Robert Schell in the Multics evaluation in 1974 [1022].

⁴Before the Internet was opened up to the public, online services were mostly standalone; bulletin boards were typically operated by hobbyists and would let subscribers or even anonymous users dial in to share information and files.

section 6.4.1). It also took steps to camouflage itself: it was called `sh`, and it encrypted its data strings (albeit with a Caesar cipher).

Its author claimed that his code was not a deliberate attack on the Internet – merely an experiment to see whether code could replicate from one machine to another. But it had a bug. It should have recognised machines that were already infected, and not infected them again, but this feature didn't work. The result was a huge volume of traffic that completely clogged up the Internet (or more accurately, its predecessor the Arpanet) despite the fact that it only affected some 10% of the 60,000 machines on the Arpanet at the time. One lesson was that sites which kept their nerve and didn't pull their network connection recovered more quickly as they could find out what was happening and get the fixes.

21.3.3 Further malware evolution

By the early 1990s, PC viruses had become such a problem that they gave rise to a whole industry of anti-virus software. Through the 1990s, operating systems acquired better access controls, making the malware writer's job harder, but the spread of interpreted languages provided plenty of new opportunities. By the start of the 21st century, the main vector was the macro languages in products such as Word, and the main transmission mechanism had become the Internet [299].

The next phase of malware evolution was to enlist the user as the propagation mechanism. The 'Love Bug' in 2000 was a worm that sent itself to everyone in the victim's address book, with the subject line 'I love you' designed to get people to open it. Its author was Onel de Guzman, a poor computer science student in Manila who wanted to collect passwords so he could use other people's ISP accounts to get online without paying [2019]. This hack to save a few dollars ended up costing millions, and taught us about the difficulty of stopping such things by filtering: a Canadian company with 85,000 staff stripped out all Windows executables at the firewall, but many of their staff had personal webmail accounts, so the Love Bug got in anyway. The company had given each employee a copy of the corporate directory in their address book, and the result was meltdown as 85,000 mail clients each tried to say 'I love you' to each of 85,000 addresses. The Love Bug was followed by similar worms which persuaded people to click on them by offering pictures of celebs such as Britney Spears and Paris Hilton.

The next development was *flash worms* which propagate by scanning the whole Internet for machines vulnerable to some exploit or other, and taking them over; examples such as Code Red and Slammer infected all vulnerable machines within hours or even minutes, and drove research into what sort of automated defences might react in time [1824].

The early 2000s also saw the rise of *spyware* and *adware*. Spyware collects and forwards information from your computer (and now, your phone) without the owner's authorization, or with at best an obscure popup that doesn't really tell you what you're agreeing to. It may also be installed by someone else, such as a parent or partner; spyware is increasingly involved in intimate partner abuse. Adware may bombard the user with advertising popups and can be bundled with spyware. The vendors of such products have even sued antivirus companies who blacklisted their wares. Some spyware is installed deliberately, whether by companies who want to keep tabs on staff, by parents who want to see what their kids are up to, or by abusive men who want to monitor and control their partners. Boundaries are difficult and different people may have different views.

A sea-change came about in 2004–6. Until then, most malware writers did so for fun or to impress their friends – basically, they were amateurs. Since then, the emergence of underground markets and crime forums has made the whole business much more professional. Malware writers now get paid money for software to recruit machines that can be sold on for cash to botnet herders and for other exploits.

Back in the amateur era, most viruses were flaky; very few actually spread in the wild. If code isn't infectious enough it won't spread, but if you make it too infectious then within a few hours the world's anti-virus vendors are upgrading their products to detect and remove it. Now that malware writers focus on money rather than bragging rights, they tend to avoid self-replicating worms in favour of more controllable exploit campaigns. (The main exception is when exploiting IoT devices that can't be patched.)

By the late 2000s, the largest botnets were using professional online marketing techniques to grow their network. Various stories were used to get people to click on a link and run a Trojan that would drop a rootkit on to their machine. Victims had to click away several warnings to install software; but Windows pops up so many annoying dialog boxes that most people just click them away. One of the first really large ones, Storm, earned its living from pump-and-dump operators and pharmacy scammers [1092]. Security researchers tried to disable big botnets by finding and taking down their command-and-control server; Storm used a peer-to-peer architecture that removed this single point of failure [1839]. In the end, it was targeted by Microsoft for removal. The same game is still being played; in March 2020 Microsoft took down Necurs, a botnet with nine million machines that had been growing for eight years, distributing banking Trojans as well as ransomware and email spam [353].

Flash worms have made a comeback since October 2016 with the Mirai worm and its variants. Mirai initially took over WiFi-attached CCTV cameras that had a known root password and software that could not be upgraded; all such devices in the IPv4 address space could be found and recruited within an hour

or so. Since then, there have been over a thousand Mirai variants attacking various IoT devices.

21.3.4 How malware works

Malware typically has two components – a replication mechanism or dropper, and a payload. A worm simply makes a copy of itself somewhere else when it's run, perhaps by breaking into another system by password guessing or using a remote code execution vulnerability (both of which were used by the Internet worm). Viruses spread in other software, perhaps as macros in documents, while Trojans are typically executed by the victim.

The second component of a virus is the payload. When activated, this may do one or more of a number of bad things:

- exfiltrate your confidential data;
- attack you directly using banking malware or spyware;
- encrypt your data and demand a ransom;
- attack others, such as when GCHQ's Operation Socialist described in section 2.2.1.9 subverted Belgacom and installed software in it to do surveillance of mobile-phone traffic passing through Belgium to other countries;
- perform some other nefarious task, such as using the CPU to mine cryptocurrency;
- install a rootkit or remote access Trojan to enable its controllers to do any of the above things, to coordinate attacks with malware on other machines, and to update itself in response to any countermeasures.

If the target is not an individual but a company – as in the Belgacom case – then the attack may involve weeks to months of work. Once attackers control a device on the target network, they will want to move sideways to map the network and find key assets such as authentication servers and mail servers so they can expand the compromise and install remote access Trojans to get a permanent presence. There are many possibilities.

1. In the old days, an attacker would install packet sniffer software to harvest passwords and compromise other accounts, eventually including a sysadmin's. Good practice nowadays is to block such attacks using two-factor authentication, or using a protocol such as Kerberos or SSH to ensure that clear text passwords don't go over the LAN.
2. Other techniques target shared resources such as file servers. For example, Linux servers may use the *Network File System* (NFS) protocol; when a volume is first mounted, the client gets a *root filehandle* from the server – an access ticket that doesn't depend on the time and can't be

revoked. We block this at our own lab using Kerberos to authenticate clients and servers. There are similar problems with Windows file shares, although the details are different; the EternalBlue vulnerability used by the WannaCry and NotPetya worm exploited such file shares.

3. Security mechanisms such as SSH bring further vulnerabilities in that machines in large organisations may have many thousands of SSH keys to communicate with each other, and intruders can exploit them and the trust structures they create to move around.

To get an idea of the range of tools available to a capable attacker nowadays, I'd suggest you browse the NSA papers released by Ed Snowden and the CIA toolkits leaked in the Vault 7 disclosure. Cyber warriors have a range of exploit kits, droppers, RATs and software for stealthy exfiltration of intelligence product.

The takeaway is that the ease with which an intruder on your network can take over other machines depends on how tightly you have the network locked down, and the damage that can follow any breach will depend on the extent to which other machines in your network trust, or are vulnerable to, the compromised machine. This is one of the arguments for not trusting local networks, but insisting on strong authentication between clients and servers at all times.

21.3.5 Countermeasures

Within a few months of the first PC viruses appearing in the wild in 1987, there were startups selling antivirus software. This led to an arms race in which virus and antivirus developers tried to outwit each other.

Early antivirus software came in basically two flavours – *scanners* and *checksummers*. Scanners search executable files for an *indicator of compromise* (IoC), typically a string of bytes from a specific virus. Malware developers responded in various ways, and the dominant technique became *polymorphism*. The idea is to change the code each time the malware replicates, to make it harder to find stable IoCs. The usual technique is to encrypt the code, and have a small header that contains decryption code. With each replication, the malware re-encrypts itself under a different key, and tweaks the decryption code by substituting equivalent sequences of instructions. Modern malware may be run through half-a-dozen such *packers* in turn, and recursively unpack itself when run. AV firms fight back by running the code in a virtual machine, so the malware devs include VM-detection code. The AV firms can at least use the unpacked code as an IoC so long as they can hack through to the last unpacking operation.

Checksummers keep a whitelist list of all the authorised executables on the system, together with checksums of the original versions, typically computed

using a hash function. The malware devs' main countermeasure is *stealth*, which in this context means that the malware watches out for operating system calls of the kind used by the checksummer and hides itself whenever a check is being done.

To provide robust defences against malware, you have to combine tools, incentives and management. We learned in the old days of DOS-based file viruses to provide a central reporting point for all incidents, and to control all software loaded on an organisation's machines. The main risks were machines used at home both for work and for other things (such as kids playing games), and files coming in from other organisations. The same principles still apply. However, firms now need a more coordinated response than before. One of the reasons is that antivirus software has been getting steadily less effective. The commercialisation of botnets and of machine exploitation has meant that malware writers operate like companies, with research and test departments. Almost all exploits are undetectable by the current antivirus products when first launched (if their writers test them properly) and many of them recruit their target number of machines without coming to the attention of the antivirus industry. The net effect was that while antivirus software might have detected almost all of the exploits in circulation in the early 2000s, by 2010 the typical product might detect only a third of them, and by 2020 you expect to detect infection after the fact and have to clean up. That means having good tool support, logging network traffic and analysing it in the light of the latest threat intelligence. What's more, the rootkit vendors provide after-sales service; if a removal kit is shipped, the rootkit vendor will rapidly ship countermeasures. And nowadays many attackers – especially the competent ones – don't leave malware files lying around but 'live off the land'; they might just add their ssh key to a list of authorised keys on one of your servers so they can pop in when they feel like it, leaving nothing for legacy AV to find.

21.4 Defense against network attack

In defending against malware and network attack generally, the view from the second edition of this book in 2008 was that you needed three things: good enough management to keeping your systems patched up-to-date and configured properly; firewalls to stop known Trojans and network exploits; and intrusion detection to monitor your networks and machines for indicators of compromise so you can catch the stuff that got through and clean up afterwards.

The principles remain the same in 2020 but reality is much more complex now, because the scale and complexity of the task have made automation

almost essential. A large Windows shop might have something like the following:

1. An agent running on each endpoint, reporting to a cloud service to give you full visibility of what software is running where and to enable you to push updates;
2. A vulnerability scanner that continually probes your network for known vulnerabilities;
3. Various boundary control devices which may include firewalls, a proxy server that filters all URLs of websites that staff visit, and proxies for critical applications;
4. An SSL gateway for staff working remotely;
5. A *bring-your-own-device* (BYOD) manager, to control laptops, phones and other devices that staff members use but that the firm doesn't own;
6. A *data leakage prevention* (DLP) system to identify staff who attempt to remove company documents or code;
7. A threat intelligence platform that integrates feeds from multiple providers, to alert you to various indicators of compromise including bad DNS names and IP addresses;
8. A log analysis tool that enables you to go back and work out when a compromise first happened, and how far it spread;
9. A *security orchestration and response* (SOAR) system that helps you respond quickly if you note that some devices in your network are communicating with bad addresses such as the command-and-control servers of known malware.

Making all this work together requires system integration, otherwise you'll have dozens of staff in your network security centre whose job is to copy lists of bad domains, bad IP addresses and other indicators of compromise from one tool to another.

That said, let's work our way down this list.

Organisations that are serious about IT security – because they are targets of state actors (like big service firms), or have demanding compliance requirements (like banks), or have a lot to lose (like the military) – aim to stop all vulnerabilities at source. This means keeping everything patched up to date, which in turn means automated patch management. But such a strategy is harder than it looks. It brings with it a number of hard subproblems, such as maintaining an accurate inventory of all the devices on your network. If you impose a rigid bureaucracy for registering new devices, people will have to find ways to circumvent it to get their work done. So you need to also scan your network to see what's there and whether it's vulnerable. And even diligent organisations may find it's just too expensive to fix all the security

holes at once; patches may break critical applications, and an organisation's most critical systems often run on the least secure machines, as administrators have not dared to upgrade them for fear of losing service.

This interacts with operational security. In Chapter 2 and Chapter 8 we discussed the practice and limitations of training staff to not expose systems by foolish actions. By the mid-2000s, the main attack vector was spearphishing – getting people to click on links in email that download and install rootkits. We learned from Ed Snowden that this was the standard way for the NSA to attack a company in 2013: they would monitor external traffic to identify sysadmins, do some background research to identify individual targets, and craft a convincing phishing lure. Alternatively they would direct the target to a website they could spoof or where they could mount a man-in-the-middle protocol attack.

You may try to educate your staff to not click on links in suspicious mail, but competent attackers create mails that don't look suspicious. And so many businesses expect their customers and suppliers to click on links that your staff will have to do some clicking to get their work done. We discussed in Chapter 3 and elsewhere that victim blaming is maladaptive; if your security systems are not usable, you have to fix them rather than blaming the poor users.

Many firms mitigate the risk by opening all mail attachments in a cloud service rather than a local machine, giving staff non-Windows machines such as Chromebooks, iPads or Macs, or having a firewall or mail filter that strips out suspicious content.

21.4.1 Filtering: firewalls, censorware and wiretaps

A *firewall* is a machine that stands between a private network and the Internet, and filters out traffic that might be harmful. It's named after the metal bulkhead that separates the passenger compartment of a car or light plane from the engine compartment, to protect the occupants from a fuel fire. Firewalls were controversial when they appeared in the mid-1990s; purists said that all the machines in a company should be secured, while firewall advocates said this was impractical. The debate has swung back and forth since.

Firewalls are just one example of systems that examine streams of packets and perform filtering or logging operations. Bad packets may be thrown away, or modified in such a way as to make them harmless. They may also be copied to a log or audit trail. Very similar systems are also used for Internet censorship and for law-enforcement wiretapping; almost everything I'll discuss in this section goes across to those applications too. Developments in any of these fields potentially affect the others; and actual systems may have overlapping functions. For example, many corporate firewalls or mail filters screen out pornography, and some even block bad language, while ISP systems that

cancel child pornography or dissenting political speech may report the perpetrators automatically to the authorities. Many filters also keep logs, so that attacks can be investigated after the fact; and in parts of the financial sector, all staff communications are required to be logged so that regulators can investigate any suspicions of insider trading or money laundering.

Filters come in basically three flavours, depending on whether they operate at the IP packet level, at the TCP session level or at the application level.

21.4.1.1 Packet filtering

The simplest kind of filter merely inspects packet addresses and port numbers. This functionality is available as standard in routers, in Linux and in Windows. You can block IP spoofing by ensuring that only 'local' packets leave a network, and only 'foreign' ones enter. It's also easy to block traffic to or from 'known bad' IP addresses. For example, IP filtering is a major component of the censorship mechanisms in the Great Firewall of China; a list of bad IP addresses can be kept in router hardware, which enables packet filtering to be done at great speed.

Basic packet filtering is often used to block all traffic except that arriving on specific port numbers. You might initially allow the ports used by common services such as email and web traffic, and then open up further ports as needed. As we move to *software defined networks* (SDN), which replace expensive routers with cheap switches controlled by software on commodity servers, packet filtering rules become just the access-control rules in the SDN controller.

However, packet filters can be defeated by a number of tricks. For example, a packet can be fragmented in such a way that the initial fragment passes the firewall's inspection but is then overwritten by a subsequent fragment, replacing the source address with one that violates your security policy. Another limitation is that maintaining a blacklist is difficult, especially when it's not the IP address specifically you want to block, but something that resolves into an IP address, especially on a transient basis. For example, phishermen use tricks like fast-flux in which a site's IP address changes several times an hour.

21.4.1.2 Circuit gateways

The next step up is a *circuit gateway* that reassembles and examines all the packets in each TCP session. This is more expensive than simple packet filtering but can also provide the added functionality of a *virtual private network* (VPN) whereby corporate traffic passed over the Internet is encrypted from firewall to firewall. I'll discuss the IPSEC protocol that's used for this in the last section of this chapter.

TCP-level filtering can be used to do a few more things, such as DNS filtering. However, such a filter can't screen out bad things at the application level, from malicious code to child sex abuse material. Thus it may be programmed to direct certain types of traffic to application filters.

21.4.1.3 *Application proxies*

The third type of firewall is the *application proxy*, which understands one or more services. Examples are mail filters that try to weed out spam, and web proxies that block or remove undesirable content. The classic objective is stripping out code, be it straightforward executables, active content in web pages, or macros from incoming Word documents. The move to web-based mail services and the adoption of https have left significantly less work for mail filters to do, and as the service firms adopt technical measures such as certificate transparency to prevent proxying, filtering needs to shift to endpoints.

An application proxy can also be a bottleneck. An example is the Great Firewall of China, which tried through the 2000s to block mail and web content that refers to banned subjects [450]. Since the adoption of https by the major service providers, and the availability of services such as Google Docs that can also be used for communication, China simply stops most of its citizens from using services like Gmail and Facebook.

In the emerging BeyondCorp model promoted by Google, proxies sit in front of the application servers themselves so that the internal network does not need to be trusted.

21.4.1.4 *Ingress versus egress filtering*

Most firewalls look outwards and try to keep bad things out, but some look inwards and try to stop bad things leaving. The pioneers were military mail systems that monitor outgoing traffic to ensure that nothing classified goes out in the clear. Around 2005 some ISPs started looking at outgoing mail traffic to try to detect spam [444]; and by now most consumer ISPs prevent their customers sending packets with spoofed source addresses. This *source address validation* means that DDoS operators using UDP reflection attacks can no longer use botnets but need to rent servers in data centres.

The fastest-growing use of egress filtering in 2020 is for *data leakage prevention* (DLP). Software that 'phones home', whether for copyright enforcement or marketing purposes, can disclose highly sensitive material, and prudent organisations increasingly wish to monitor and control this kind of traffic. But the pervasive use of https means that DLP systems typically need to install software on endpoints rather than using middleboxes.

21.4.1.5 Architecture

For years, many firms bought a firewall to keep their auditors happy. If that's your pain point, a simple filtering router won't need much maintenance and won't get in the way too much. At the other extreme, a serious firewall system at a defence contractor might consist of a packet filter connecting the outside world to a screened subnet, also known as a *demilitarized zone* (DMZ), which in turn contains a number of application servers or proxies to filter mail, web and other services. You may also expect to find data diodes separating networks operating at different clearance levels, to ensure that classified information doesn't escape either outwards or downwards (Figure 21.2).

An alternative approach is to have more networks, but smaller ones. At our university, we have firewalls to separate departments, although we've got a shared network backbone and some shared central services such as logging. There's no reason why the students and the finance department should be on the same network, and a computer science department has got quite different requirements from a department of theology. Keeping each network small limits the scope of any compromise and helps incentivise system administrators to defend it.

Considerations in the design of a network security architecture include simplicity, usability, deperimeterisation versus re-perimeterisation, underblocking versus overblocking, maintainability, and incentives.

First, since firewalls do only a small number of things, it's possible to make them simple to remove sources of vulnerability and error. If your organisation has a heterogeneous population of machines, then loading as much of the security task as possible on a small number of simple boxes makes sense. On

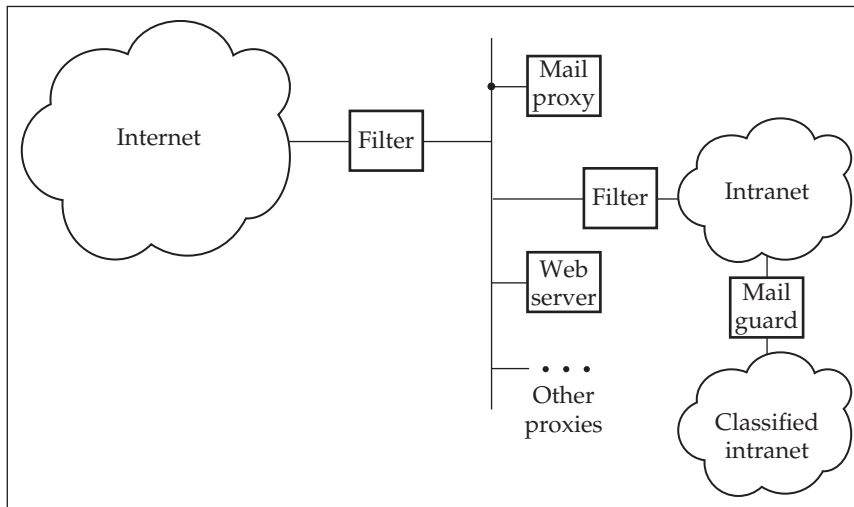

Figure 21.2: complex firewalls for an MLS network

the other hand, if you're running something like a call centre, with a thousand identically-configured PCs, it makes sense to put your effort into keeping this configuration tight. These are roughly the energy utility, and Google, models discussed in the introduction at the start of this chapter.

Second, elaborate central installations not only impose greater operational costs, but can get in the way so much that people install back doors, such as cable modems that bypass the firewall, to get their work done. I will discuss in section 20.4 how diplomats have come unstuck by using private email when their official systems were unusable. Many well-run firms have open guest networks, as does our department; there's always got to be something that works. And a prudent system administrator will monitor the actual network configuration rather than just relying on 'policy'.

Third, firewalls only work until people find ways round them. Early firewalls let only mail and web traffic through; so writers of applications from computer games to anonymity proxies redesigned their protocols to make the client-server traffic look as much like normal web traffic as possible. Then everything moved to Web 2.0 and such filters became largely ineffective.

Next, there's deperimeterisation – as Google's BeyondCorp notes, it's becoming steadily harder to put all the protection at the perimeter, thanks to the proliferation of phones and PDAs being used for functions that used to be done on desktop computers, and by changing business methods that involve more outsourcing of functions – whether formally to subcontractors or informally to advertising-supported web apps. If some parts of your organisation can't be controlled (e.g., the sales force and the R&D lab) while others must be (the finance office) then you may need separate architectures. The proliferation of web applications is complemented by a blunting of the incentive to do things at the perimeter, as useful things become harder to do. The difference between code and data is steadily eroded by new scripting languages. Many firms tried to block JavaScript in the early 2000s but were beaten by popular web sites that require it. Nowadays it may be impossible to prevent your staff attaching large numbers of IoT devices that just cannot be secured at all [1256].

And then there's our old friend the Receiver Operating Characteristic or ROC curve. No filtering mechanism has complete precision, so there's inevitably a trade-off between underblocking and overblocking. If you're running a censorship system to stop kids accessing pornography in public libraries, do you underblock, and annoy parents and churches when some pictures get through, or do you overblock and get sued for infringing free-speech rights? Things are made worse by the fact that the firewall systems used to filter web content for sex, violence and bad language also tend to block free-speech sites (as many of these criticise the firewall vendors – and some offer technical advice on how to circumvent blocking).

And as we've repeatedly pointed out, security depends at least as much on incentives as on technology. A sysadmin who looks after a departmental network used by a hundred people they know, and who will personally have to clear up any mess caused by an intrusion or a configuration error, is much more motivated than someone who's merely one member of a large team looking after thousands of machines.

21.4.2 Intrusion detection

Attacks will happen, and it's often cheaper to prevent some attacks and detect the rest than it is to try to prevent everything. The systems used to detect bad things happening are referred to generically as *intrusion detection systems* (IDS). The antivirus software products I discussed earlier are one example; but the term is most usually applied to boxes that sit on your network and look for signs of an attack in progress or a compromised machine [1639]. Examples include:

- a machine trying to contact a 'known bad' service such as an IRC channel that's used to control a botnet, or a known-bad IP address – or trying to resolve a known-bad DNS name;
- packets with forged source addresses – such as packets that claim to be from outside a subnet but that actually originate from it;
- spam coming from a machine in your network.

In cases like this, the IDS typically tells the sysadmin that a particular machine needs to be looked at. This may be just the first step in an investigation that involves staring at logs to see how it happened, and what else the attackers might have infected.

Other examples of intrusion detection, which we've seen in earlier chapters, include mechanisms for detecting payment card fraud and stock-market systems that look for insider trading, such as via increases in trading volume just before a price-sensitive announcement. This is now an active area of research: the boom in AI since 2012 has created lots of startups looking for pattern-matching problems.

21.4.2.1 Types of intrusion detection

The simplest intrusion detection method is to sound an alarm when a threshold is passed. Three or more failed logons, a credit card expenditure of more than twice the moving average of the last three months, or a mobile phone call lasting more than six hours, might all flag an account for attention. More sophisticated systems generally fall into two categories.

Misuse detection systems operate using a model of the likely behaviour of an intruder. A banking system may alarm if a user draws the maximum permitted amount from a cash machine on three successive days; and a Unix intrusion detection system may look for user account takeover by alarming if a previously naive user suddenly starts to use sophisticated tools like compilers. Simple misuse detection systems, such as antivirus scanners, look for a *signature* – a known characteristic of a specific attack. This can be either explicit in the data (such as a substring of an executable file that marks it as a specific piece of malware) or in behaviour (such as a machine contacting the IP address of a known botnet command-and-control server). More complex misuse detection systems treat a number of signatures as signals and then train a machine-learning classifier to make the decisions. As I discussed in section 12.5.4, the systems used to detect card fraud use dozens of signals, as they need low false alarm rates to be useful given the scale of modern payment systems.

Anomaly detection systems attempt the much harder job of looking for anomalous behaviour in the absence of a clear model of the attacker's modus operandi. The hope is to detect attacks that have not been previously recognized and cataloged. Systems of this type have used AI techniques since the 1990s, though some firms eschew them; Google policy, for example, is to avoid systems that try to learn thresholds or automatically detect causality, and instead have simple systems that detect changes in end-user request rates [237].

The dividing line between misuse and anomaly detection is somewhat blurred. A borderline case is Benford's law, which describes the distribution of digits in random numbers. One might expect that numbers beginning with the digits '1', '2', ... '9' would be equally common. But when numbers come from random natural sources and span more than one order of magnitude, so that their distribution is independent of the number system in which they're expressed, the distribution is logarithmic: about 30% of decimal numbers start with '1'. Crooked clerks who think up numbers to cook the books, or even use random number generators without knowing Benford's law, are often caught this way [1249].

Another borderline case is the *honeypot* – something enticing left to attract attention. I mentioned, for example, that some hospitals have dummy records with celebrities' names in order to entrap staff who ignore patient confidentiality. In the network context, honeypots emulate many types of device so that attackers scanning the Internet looking for (say) a DSL modem of a particular upgrade status find one to attack; this may contain either a simple emulator, or with more recent designs, the actual modem firmware running in a VM [1959]. The upshot is that the honeypot operator gets to see who's attacking what, and how.

21.4.2.2 *General limitations of intrusion detection*

Some intrusions are obvious. If you're worried about activists vandalising your web site, then have a machine somewhere that fetches the page frequently and rings an alarm when it changes. But in the general case, intrusion detection is hard. The virus pioneer Fred Cohen proved that detecting viruses (in the sense of deciding whether a program is going to do something bad) is as hard as the halting problem, so we can't ever expect a complete solution [452].

There's also a matter of definitions. Some intrusion detection systems are configured to block some kinds of suspicious behaviour. But this turns the intrusion-detection system into an access control mechanism, as well as opening the door to service-denial attacks. I prefer to define an intrusion-detection system as one that monitors the logs and draws attention to suspicious occurrences.

Then there's the cost of false alarms. Academic machine-learning researchers often consider they've done well when they train a classifier to have a false alarm rate of 0.1%. But if you're on the Gmail team and dealing with a billion users authenticating themselves every day, that's way too much. Large-scale systems need really low false alarm rates.

Finally, there are three generic problems with machine-learning classifiers: the facts that they're not much good at detecting new attacks, that people game them, and that they inhale the prejudices of their training data. We will discuss these in more detail in section 25.3.

21.4.2.3 *Specific problems detecting network attacks*

Turning now to the specific problem of detecting network intrusion, it's harder to spot than payment fraud. Network intrusion detection products still have high missed alarm and false alarm rates. It's common to detect actual intrusions only afterwards. The reasons for the poor performance include the following, in no particular order.

- The Internet is a very noisy environment – not just at the level of content but also at the packet level. A lot of random crud arrives at any substantial site, and enough of it can be interpreted as hostile to provide a significant false alarm rate. Many bad packets result from software bugs; others are the fault of out-of-date or corrupt DNS data; and some are local packets that escaped, travelled the world and returned [214].
- There are 'too few attacks'. If there are ten real attacks per million sessions – which is almost certainly an overestimate – then even if the system has a false alarm rate as low as 0.1%, the ratio of false to real alarms will be 100. We talked about similar problems with burglar alarms; it's also a well-known problem for medics running

screening programs for diseases like HIV where the test error rate exceeds the disease prevalence. Where the signal is way below the noise, the guards get tired and the genuine alarms get missed.

- While a theft from a bank causes an incorrect state – money in the wrong place, and evidence on the audit trail – many network intrusions aim to avoid this, for example if their mission is to exfiltrate confidential data. It's easier to write software to detect errors than it is to detect slightly odd behaviour.
- Many network attacks are specific to particular versions of software, so you need a large and constantly-changing library of attack signatures. However, many firms buy intrusion detection systems in order to satisfy insurers or auditors, and the products aren't always kept up to date.
- As more and more traffic is encrypted, it can't easily be subjected to content analysis or filtered for malicious code. If DNS-over-https becomes the norm, tools that rely on analysing your DNS traffic will become much less effective.
- The issues we discussed in the context of firewalls largely apply to intrusion detection too. You can filter at the packet layer, which is fast but misses a lot; or you can proxy your applications, which is expensive – and needs to be constantly updated to cope with new applications and attacks.
- You may have to do intrusion detection both locally and globally. More and more things have to be done on local machines, thanks to encrypted web sessions; but some attacks are *stealthy* – the opponent sends 1–2 packets per day to each of maybe 100,000 hosts, and you need a central monitor that counts packets by source and destination address and by port.

Nowadays, intrusion detection systems involve the coordination of multiple monitoring mechanisms and products at different levels both in the network and on your fleet of endpoint devices. A large company with tens of thousands of staff using Windows will typically have several dozen products, as I discussed previously in section 21.4. Integrating and automating both monitoring and response makes up more and more of a CISO's job. The growth areas therefore include integration tools for *security incident and event management* (SIEM), *security orchestration and response* (SOAR), and metrics.

21.5 Cryptography: the ragged boundary

Network security interacts with cryptography in a number of ways. We already mentioned the debate about DNS over https; now I'm going to describe five

other aspects of crypto briefly. They are SSH; the local link protection offered by WiFi, Bluetooth and HomePlug; the IPSec mechanisms used in VPNs; TLS; and the *public key infrastructures* (PKI) used to support many of these. In the previous chapter, we discussed how attempts to build more trustworthy components out of cryptography run up against many real-world engineering and economic constraints. The tools that we use to set boundaries on networks, and to translate trust within them, are no different.

The emerging themes are that the most distributed part of the problem is unmanageable because the vendors don't care; in particular the thousands of device types being marketed as part of the 'Internet of Things' have no remote management facility available to users, the vendor often doesn't upgrade the software, and the lack of a user interface means that authentication is haphazard at best. Meanwhile the most centralised part of the problem – PKI – is often subverted by government mandates.

21.5.1 SSH

When I use my laptop to access files on my desktop machine, or do anything with any other machine in our lab for that matter, I use *secure shell* (SSH) which provides encrypted links between Unix and Windows hosts. So when I work from home, my traffic is protected, and when I log on from the PC at my desk to another machine in the lab, the password I use doesn't go across the LAN in the clear.

SSH was initially written in 1995 by Tatu Ylönen, a researcher at Helsinki University of Technology, following a password-sniffing attack there [2061]. It sets up encrypted connections between machines, so that logon passwords don't travel across the network in the clear, and supports other useful features that led to its rapid adoption [1620].

There are various configuration options, but in the most straightforward one, each machine has a public-private keypair. The private key is protected by a passphrase that the user types at the keyboard. To connect from my laptop to a server at the lab, I install my laptop public key in a file on the relevant server. When I wish to log on to a server I'm prompted for my passphrase; the two machines set up a Diffie-Hellman key; the private keys are used to sign the transient public keys, to stop middleperson attacks; the subsequent traffic is thus both encrypted and authenticated. Manual key installation is intuitive, but doesn't scale particularly well. There are also options to use Kerberos, whether to authenticate the session key set up using Diffie-Hellman, or to set up the session key directly. (In the latter case, SSH falls back to being a variant of Kerberos in the sense that it is now a trusted third-party protocol, and the police can get the Kerberos server to decrypt the traffic.)

Possible problems include the fact that if you're typing at the keyboard one character at a time, then each character gets sent in its own packet, and

the packet interarrival times can leak a lot of information about what you're typing [1807]. However, the worst is probably that most SSH keys used for server-to-server communication are stored in the clear, without being protected by a password at all. So if a server is compromised, the same can happen to every other machine that trusts an SSH key installed on it.

SSH is often used as a simple logon mechanism; many IoT devices run Linux and allow remote logon by anyone who knows an appropriate password. This opens them to password-guessing attacks, and where there are weak passwords or a known default password, to recruitment into botnets based on Mirai and similar tools. The countermeasure here is honeypots.

21.5.2 Wireless networking at the periphery

Many networks use wireless technology at the edge to go the last few feet from an access point to a device, or from one device to another. Protocols such as WiFi, Bluetooth and HomePlug all offer encryption to provide some protection against service abuse and perhaps against eavesdropping. However most are vulnerable to local attacks that are difficult to block completely because many devices don't get patched, lack user interfaces, or both.

21.5.2.1 WiFi

WiFi supports wireless local area networks, whether at home to connect phones and other devices to a home router, or by businesses to connect payment terminals and stock control devices as well as PCs. It has come with a series of encryption protocols since its launch in 1997. The first widely-used one, WEP (for *wired equivalent privacy*), was shown to be fairly easily broken because of the weak ciphers demanded by US export control and poor protocol design [300, 1876]. Since 2004, an improved system called WPA2 uses AES encryption. The key for each access point is typically printed on a card that fits into the back of the router.

Should WiFi networks be seen as untrusted? The reason to set a password is more to prevent third parties using your bandwidth or quota, rather than the risk of pharming. Many people in the UK or America find it convenient to have an open network for guests to use, and so that you and your neighbours can use each others' networks as backups. In countries where you pay for download bandwidth, home router passwords are mostly set. In some, like India, it's against the law to run an open WiFi access point (terrorists who mounted an attack in Bombay in 2008 used them to call home unobtrusively). Having the key on a card is a neat example of usable security design: the householder can make their network as open or as secure as needed by pinning the card on the wall or by locking it up.

WiFi security is still somewhat fragile. *Universal Plug and Play* (UPnP) lets any device in a network punch a hole through the router's firewall; DHS has been recommending since 2013 that people turn it off. However now that many devices and domestic appliances come with an attached cloud service, that's hard. It's used along with *WiFi Protected Setup* (WPS) which lets you enrol gadgets on your network with a simple button press. You can set a PIN but there have been a couple of attacks found on the mechanism.

Businesses may have to take a bit more care. In March 2007, retail chain TJ Maxx reported that some 45.7 million credit card numbers had been stolen from its systems; the Wall Street Journal reported that an insecure WiFi connection in St Paul, Mn., was to blame [1511]. Banks sued the company, and eventually settled for \$41m [789].

Patching is an issue. For example, in March 2020 we learned of the Kr00k vulnerability in Broadcom WiFi chips which will get patched in Macs and iPhones but probably not in wireless routers or older Android phones [800]. As for the great majority of IoT devices, from toys through home appliances, they won't get patched, ever.

21.5.2.2 Bluetooth

Bluetooth is another short-range wireless protocol, aimed at *personal area networks*, such as linking a headset to a phone, or a phone in your pocket to a hands-free interface in your car. It's also used to connect cameras and phones to laptops, keyboards to PCs and so on. Like WiFi, the first versions of the protocol turned out to have flaws [1103, 1716]. From version 2.1 (released in 2007), Bluetooth has supported Secure Simple Pairing, which uses elliptic-curve Diffie-Hellman to thwart passive eavesdropping attacks. Man-in-the-middle attacks are dealt with by generating a six-digit number for numerical comparison. However, because one or both of the devices might lack a keyboard or screen (or both), it's also possible for the number to be generated at one device and entered as a passkey at another; and there's a 'just works' mode that's not protected against middleperson attack. What's more, the data may or may not be signed, giving a total of about ten different combinations of confidentiality, integrity and resistance to man-in-the-middle attack; and a number of attacks have been found, some inspired by NSA tools listed in the Snowden disclosures [1638]. Again, patching is an issue. In 2018, Eli Biham found that many implementations could be fooled by a man-in-the-middle supplying an invalid elliptic curve to the authentication protocol [245], and in 2020 Daniele Antonioli and colleagues discovered a variant of the man-in-the-middle attack where you just reflect the challenge from a bluetooth device back to it, claiming that you're now the challenger

and the target device is the responder [126]. So if you have a device with a bluetooth chip that hasn't been patched, it may be vulnerable.

21.5.2.3 HomePlug

HomePlug is a protocol used for communication over the mains power cables. HomePlug AV is widely used in WiFi extenders: you plug one station into your router or cable modem, and another gives a remote WiFi access point at the other end of your house. (Declaration of interest: I was one of the protocol's designers.) We were faced with the same design constraints as the Bluetooth team: not all devices have keyboards or screens, and we needed to keep costs low. We decided to offer only two modes of operation: secure mode, in which the user manually enters into their network controller a unique AES key that's printed on the device label, and 'simple connect' mode in which the keys are exchanged without authentication. The keys aren't even encrypted in this mode; its purpose is not to provide security but to prevent wrong associations, such as when a device wrongly mates with a network next door [1438]. However many vendors just support the 'simple connect' mode and end up with a policy of trust on first use, as already mentioned in section 4.7.1. Others sell extenders in pairs, with keys already installed. There are variants for smart meters to communicate with substations, and for electricity utilities to provide broadband to the home over the power line (though these are not widely used because of radio frequency interference). Vendors also customised the product in various ways to make it incompatible with competitors. As a result of this mess, little reliance can be placed on the key management.

21.5.2.4 VPNs

Virtual private networks (VPNs) typically do encryption and authentication at the IP layer using a protocol suite known as IPsec. This defines a *security association* as the combination of keys, algorithms and parameters used to protect a particular packet stream. Protected packets may be just authenticated, or encrypted too; in the former case, an authentication header is added that protects data integrity, while in the latter the packet is also encrypted and encapsulated in other packets. There's also an *Internet Key Exchange* (IKE) protocol to set up keys and negotiate parameters, and we may infer from Ed Snowden's disclosures that the standard default settings of this (with 1024-bit Diffie-Hellman) are insecure.

VPNs are offered by firewall vendors so that by installing one of their boxes in each branch between the local LAN and the router, all the internal traffic can pass encrypted over the Internet. Individual workers' laptops and home

PCs can also join a VPN given appropriate software. VPNs are also offered commercially, and are used for example by people and firms in countries like Iran and China to circumvent the national firewall.

21.6 CAs and PKI

As we discussed in section 5.7.4, the pioneers of public-key cryptography developed a vision of certificates that would bind public keys to the names or roles of the organisations, people or devices that controlled the corresponding private keys. Initially it was thought that governments or phone companies would do this, but they were too slow. During the dotcom boom, entrepreneurs set up *certificate authorities* (CAs) and software firms such as Microsoft and Netscape embedded their public keys into their browsers. There followed a gold rush as the CAs bought each other and consolidated; investors hoped that every device would need a public-key certificate, so you'd need to pay Verisign ten bucks every two years to renew the certificate on your toaster, or it wouldn't talk to your fridge.

Once that foolishness died down, the world's governments moved to get their own CAs' root certificates into the browsers for intelligence and surveillance purposes. As people moved to web services like Gmail, security agencies developed tools to do man-in-the-middle attacks, and as TLS was used to encrypt password entry (and later, the whole session), this meant having a CA that would produce a certificate on `www.gmail.com` for a security agency public key that the target's browser would accept. In fact, at a panel discussion at Financial Cryptography 2011, I asked the man from Mozilla how come, when I updated Firefox the previous day, it had put back a certificate I'd removed for Tubitak – a Turkish intelligence organisation. At this point a man stood up in the audience and shouted 'How dare you insult my country! Tubitak is not an intelligence agency – it is a research organisation!' The man from Mozilla shrugged and said wryly, 'Now you see how hard certificate governance is.'

Later that year came the DigiNotar scandal. DigiNotar was a Dutch CA which was found to have issued wildcard certificates for Gmail. Iranian agents had hacked it in order to monitor 300,000 Gmail users in Iran; sanctions meant that, unlike Turkey, they could not just have their government certificate installed in the major browsers. Mozilla and Google promptly put DigiNotar to death by removing its root certificates; Microsoft and Apple followed quickly. This caused real disruption in the Netherlands, many of whose online government services used DigiNotar certificates, and had to scramble to get others. It turned out that there had been earlier attacks on another CA, Comodo, but that company claimed to have revoked all its wrongly-issued certificates. Since then, there has been increasing pressure on CAs and auditors from the browsers' root stores.

There is frequent semantic confusion between ‘public (key infrastructure)’ and ‘(public key) infrastructure’. In the first, the infrastructure can be used by whatever new applications come along; I’ll call this an *open PKI*. In the second, it can’t; I’ll call this a *closed PKI*. If you’re building a service that government agencies are likely to attack, then it may be a good idea to keep your PKI closed, with a CA that runs on your own premises – so you get to know of any warrants. I advise firms who maintain software that’s installed on many millions of machines to use a private CA for their code signing keys.

PKI has a number of intrinsic limitations, many of which we discussed in the chapter on distributed systems. Naming is difficult, and the more applications rely on a certificate, the shorter its useful life will be. You can sometimes simplify things by removing unnecessary names: rather than one certificate saying ‘Ross Anderson’s key is KR’ and another saying ‘Ross Anderson has the right to administer x.foo.com’ you might just say ‘KR has the right to administer x.foo.com.’

This is an aspect of the ‘one key or many’ debate. Should I expect to have a single digital credential to replace each of the metal keys, credit cards, swipe access cards and other tokens that I currently carry around? Or should each of them be replaced by a different credential? Multiple keys protect the customer: I don’t want to have to use a key with which I can remortgage my house to buy my lunchtime sandwich. As we saw in the chapter on banking and bookkeeping, it’s easy to dupe people into signing a message by having the equipment display another one.

Now the standard PKI machinery (the X.509 protocol suite) was developed to provide an electronic replacement for the telephone book, so it started off by assuming that everyone will have a unique name and a unique key in an open PKI architecture.

This in turn leads to issues of trust, of which there are many.

- If you remove one of the hundreds of root certificates from Firefox, then Mozilla silently replaces it; Windows comes with even more root certificates – but you can’t delete them at all. In each case, you have to know how to mark a certificate as untrusted.
- There have been some interesting effects where a government that had its cert in Windows but not in other browsers (such as Thailand’s, after the military coup in 2014) had to resort to different surveillance methods for Mac users [1557].
- Many firms use certs that are out-of-date, or that correspond to the wrong company, often because the firm’s marketing department got a contractor to run some promotion or another. As a result, users have been trained to ignore security warnings, and only a small minority used to pay attention to them [842]. Recently browsers such as Firefox have made it harder to click past warnings.

- Certs bind a company name to a DNS name, but their vendors are usually not authorities on either; they hand out certificates after checking that the applicant can answer an email sent to that domain, or put up a web page with a CA challenge on it. Things are slightly better with ‘extended validation’ certificates⁵, but even they aren’t foolproof.
- On their ‘certification practice statements’ CAs go out of their way to deny all liability.
- Certificate revocation is an issue. The original idea was that anyone relying on a cert could download a *certificate revocation list* (CRL) from the CA and check any cert on which they were about to rely. However, this vitiated much of the benefit of public-key cryptography by requiring online operation for high assurance. In addition, users of some systems (particularly US government ones) had to download large CRLs every time they started up their systems, leading to delay and network congestion. Since about 2013, people have moved to the *Online Certificate Status Protocol* (OCSP), a more efficient protocol for online status checking.

Behind all this mess lies, as usual, security economics. During the dotcom boom in the 1990s, the SSL protocol (as TLS then was) won out over a more complex and heavyweight protocol called SET, because it placed less of a burden on developers [111]. The costs of compliance were dumped on the users – who are often unable to cope [524]. Much of the engineering around CAs and certs since then has been playing catchup.

The big issues at the time of writing are certificate lifetime; LetsEncrypt; and certificate transparency.

The maximum permitted lifetime of a certificate, if it’s to be accepted by the main browsers, has steadily reduced from 8 years to 3 years to 27 months. Ballots in 2017 and 2019 proposed a cut to 13 months [1584] and in 2020 Apple forced the issue by declaring that from September, its devices would no longer accept any certs valid for longer than 398 days [1448]. This will force many websites to refresh their certificates; it will be interesting to see how firms flush out all the certs in DNS. (It will also widen the gap between systems with annual certs and some industrial and IoT systems where certs have to last for years because of the difficulty of software upgrade.)

Getting certs used to be difficult as you had to go shopping for one, prove you controlled your domain, get the cert, upload it to your server, change the configuration and then test it all. The change maker here has been a nonprofit, the Internet Security Research Group (ISRG) which provides certs for free and by February 2020 had issued a billion of them. Making certs free allowed full

⁵These used to bring up a green padlock in your browser, though this is being discontinued in Chromium from v 76 in 2020 after research showed that nobody paid any attention.

automation, which keeps costs down: their 'LetsEncrypt' CA supports 100m sites on a budget of \$3m pa. LetsEncrypt set out to make deploying certs easy, and the impact has been real: 20% of browser connections are still in plaintext, but this is down from 60% four years ago. This service started in 2015, two years after the Snowden revelations. Their automated certificate management environment is now standardised as RFC8555, so commercial CAs are using it too. There's a transparency log and the system has no manual override, so there's some assurance that they have never been compelled to issue a cert. (In fact, the NSA uses their certs.) At November 2019, they were the largest CA, with 112m certs for 188m domains; they had 5% of the top hundred sites but 35% of the top million. Their scale means that mistakes affect lots of sites; in March 2020, a bug in their software meant that 3 million certificates covering 12 million server names had to be replaced [590].

Following the attacks on Comodo and DigiNotar, work started on mechanisms to block maliciously issued certificates. Certificate transparency sets out to do this by maintaining logs of all the certificates seen in the wild for each domain, so that domain owners can rapidly spot certs that should not have been issued for their domain. Google launched the first certificate transparency log in 2013 and Chrome started insisting on such logs for extended validation certificates in 2015. Google found that Symantec had issued certificates for a number of domains (including their own) without the domain owner's knowledge [1790], and made certificate transparency mandatory for all CAs in 2018.

21.7 Topology

The topology of a network is the pattern in which its nodes are connected, and this can be a significant component of the security architecture.

- A utility might have a number of islands, each containing a generator or substation with dozens to hundreds of devices on a trusted network, connected in turn via a specialised firewall and a VPN to a network control centre.
- A cloud service provider might have tens of thousands of machines in a data centre, with hierarchies of certificates issued both by the provider and its tenants determining which VMs or containers on which machines can communicate with each other. And while the internal network may be untrusted, in the sense that network location plays no role in access control decisions, it may be shielded from DDoS attacks by front-end systems.
- Classified systems used by governments may have quite large trusted networks operating at elevated levels, with separate LANs in buildings.

More complex topologies can be found where nodes are users and edges are their presence in each others' address books. Social-network analysis has been applied to disciplines from epidemiology through criminology and the study of how new technologies diffuse, to the study of harms transmitted directly between users, such as macro viruses [1435]. Social networks can be modelled by a graph with a power-law distribution of vertex order; a small number of well-connected nodes help make the network resilient against random failure, and easy to navigate. Yet they also make such networks vulnerable to targeted attack. Remove the well-connected nodes, and the network is easily disconnected [37]. Dictators have known this intuitively; Stalin consolidated his rule by killing the richer peasants, Pol Pot killed intellectuals, while William the Conqueror killed the Saxon gentry. Now we have quantitative models, they help explain why revolutionaries have tended to organise themselves in cells [1375]; by doing traffic analysis against just a few well-connected organisers, a police force can identify a surprising number of members of a dissident organisation – unless the dissidents organised in a cell structure in the first place [510].

21.8 Summary

Preventing and detecting attacks that are launched over networks is the core of a modern CISO's job. It's difficult because it involves a huge range of attack types and security technologies. It can lead to newsworthy failures. There is unlikely to be any magic solution, though a lot of things can help. Each new advance opens up new things to worry about; for example, cloud services may shift much of the network security task to a provider, but make configuration management more critical. Overall, the problems are so complex and messy that managing them needs a whole-system approach with automation.

Hacking techniques depend partly on the opportunistic exploitation of vulnerabilities introduced accidentally by the major vendors, and partly on techniques to social-engineer people into running untrustworthy code. However these have developed into a whole ecosystem of bad guys, which a security engineer also needs to study and understand.

Research problems

In 2000, the centre of gravity in network security research was technical: we were busy looking for new attacks on protocols and applications as the potential for denial-of-service attacks started to become clear. By 2010, there was much more discussion of economics and policy: of how changing liability rules

might make things better [98]. By 2020, there is much more work on metrics: on measuring the actual wickedness that goes on, and feeding this not just into the policy debate but also into law enforcement. At the operational level, the game is about automation and integration – about enabling large firms to process large quantities of threat intelligence and network surveillance information, turn it into actionable intelligence, and measure how effectively the network security team is doing its job.

Further reading

The early classic on Internet security was written by Steve Bellovin and Bill Cheswick, with Avi Rubin joining them for the second edition [222]. The seminal work on viruses is by Fred Cohen [452], while Java security is discussed by Li Gong (who designed it) [784]. For BGP security, see our 2011 ENISA report: the full Monty is over two hundred pages, designed for people starting a PhD in network security, but there's a shorter executive summary too [1910].

For a more detailed overview of malware, I might suggest Wenke Lee's Cybok survey paper [1139]; and Sanjah Jha's Cybok survey of network security provides more detail of IPSEC as well as ethernet and port-based security [985].

I'm not aware of any good overview of the certification authority ecosystem. You might start with the 2004 oral history interview with Jim Bidzos, the founder of Verisign [241]. The initial goal of Microsoft and Netscape was to jump-start electronic commerce on the worldwide web; certificate use then spread to passwords and software updates, and when Javascript came along, the same origin principle shifted trust to websites. Many other players jumped in, with some government agencies trying to undermine the CA ecosystem and others trying to reinforce it. There's conflict between technical security goals and legal goals, as well as between auditors and regulators. So there are quite separate views on CA security from WebTrust (the American and Canadian accountants) and ETSI (the most relevant European standards body). For more detail, a presentation by Ryan Sleevi on what's wrong with the ecosystem [1789] has many pointers for those who want to dig into the current problems, both technical and operational, and their background.