

Real Time Audio and Video Transmission of IEEE GLOBECOM'96 over the Internet

Colin Perkins, Jon Crowcroft
University College London

22 November 1996

Abstract

This article is about the experiences that we had in transmitting the proceedings of some events at the IEEE Globecom '96 in London, England, in the week of 17-22 November, 1996.

Live Video and Audio of all of the events in the Churchill Auditorium of the Queen Elizabeth II Conference Center we captured and transmitted, in real time, as well as stored and transmitted later, for remote participants in 3 continents, over the Internet.

Two independent systems were used simultaneously, one supplied by researchers from NTT laboratories in Japan, and the other by researchers from UCL. The former system is based on a server model of distribution¹, whilst the latter is based on the use of network level packet multicast.

Both systems employ compression algorithms so that the network capacity requirement in each case was of the order of 100 kbps to 200 kbps total, thus enabling remote participants without very high end network connectivity to take part. Receivers need only software for a PC running most popular versions of Windows or a Unix workstation to be able to receive either type of transmission, or to retrieve the recorded sessions from NTT laboratories' servers.

The multimedia transmission was carried over carefully engineered links that traversed many different subnet technologies, including point-to-point circuits, SMDS networks, ATM networks, and fast Ethernet switches. This was both to give a high level of assurance that the traffic would not experience too much interference from other traffic at the site and elsewhere, and to ensure very low packet store and forward delays.

The system ran for 4 days continuously, and was generally very successful. In the future, it should be possible to have remote paying attendees.

Overview

This article is about the experiences that we had in transmitting the proceedings of some events at the IEEE Globecom '96 in London, England, in the week of 17-22 November, 1996.

Initially, staff from the Department of Computer Science, UCL were asked to organize a mini-conference within Globecom, on the subject of the Internet. It was then decided to add a technical exhibition, and to consider transmitting the event over the Internet, at the request of NTT laboratories and some other research institutions in Japan and the USA.

We quickly formed a list of the technical staff to be involved from BT, MCI, NTT, UCL and UKERNA, and set up an E-mail list, shared computer accounts, and established basic Internet service provider relations and connectivity.

Live Video and Audio of all of the events in the Churchill Auditorium of the Queen Elizabeth II Conference Center we captured and transmitted, in real time, as well as stored and transmitted later, for remote participants in 3 continents, over the Internet.

¹In some senses this is analogous to the use of an MCU in the ISDN/H.320 videoconferencing world, except that here we are packet based, not circuit based. Another system like this is the CU-SeeMe reflector based multi-party video conferencing tool

Two independent systems were used simultaneously, one supplied by researchers from NTT laboratories in Japan, and the other by researchers from UCL. The former system is based on a server model of distribution², whilst the latter is based on the use of network level IP packet multicast.

Both systems employ compression algorithms³ so that the network capacity requirement in each case was of the order of 100 kbps to 200 kbps total, thus enabling remote participants without very high end network connectivity to take part. Receivers need only software for a PC running most popular versions of Windows or a Unix workstation to be able to receive either type of transmission, or to retrieve the recorded sessions from NTT laboratories' servers.

The multimedia transmission was carried over carefully engineered links that traversed many different subnet technologies, including point-to-point circuits, SMDS networks, ATM networks, and fast Ethernet switches. This was both to give a high level of assurance that the traffic would not experience too much interference from other traffic at the site and elsewhere, and to ensure very low packet store and forward delays.

The system ran for 4 days continuously, and was generally very successful. In the future, it should be possible to have remote paying attendees, although reliability would become an important question in such instances. It has been suggested that receivers could *lease* a key to decrypt an encrypted video stream, much along the lines used for satellite and cable TV pay-per-view systems. Reselling of the material would not be prevented, but at least live virtual attendance would be limited, and by changing encryption keys regularly, the growth of the community able to "spy" on the event could be constrained. This will have to be investigated by the IEEE, and any other organisations interested in using this technology in anger.

There were three networked areas in the conference centre: exhibits, cyber-cafe and the main auditorium. Each of these areas is served by a separate Ethernet, and these are linked via a CISCO router in the basement. Access to the Mbone is via an external link from the CISCO. This is illustrated in figure 1. Originally, the Cisco router was going to terminate tunnels from the BTnet machine, `news-feed2.bt.net`, but due to interworking problems of the versions of DVMRP, the multicast routing protocol, we ended up setting up an Mbone tunnel from the Mbone1 machine to the mbone machine within BTnet.

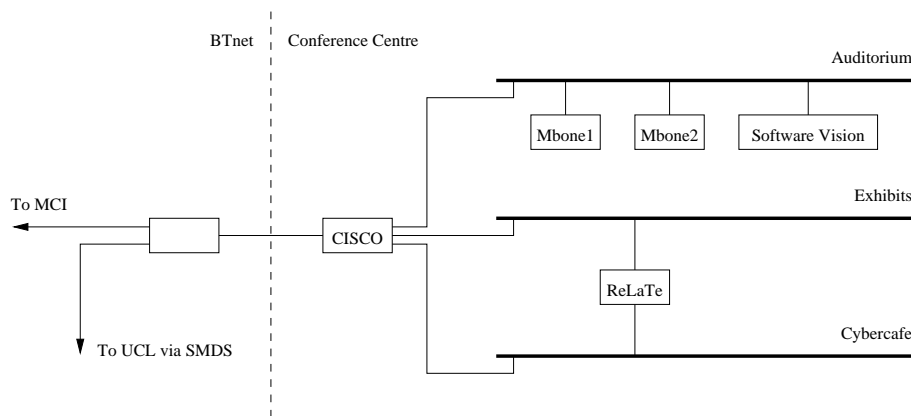

Figure 1: Planned Network Layout

UCL provided four machines: two for the multicast of the conference sessions, and two to provide a demo and multicast routing for the exhibit/cafe areas. Two systems were provided by NTT to broadcast the conference sessions using the SoftwareVision system.

The machines provided by UCL functioned as follows:

Mbone1 Main mouted and first video feed.

²In some senses this is analogous to the use of an MCU in the ISDN/H.320 videoconferencing world, except that here we are packet based, not circuit based. Another system like this is the CU-SeeMe reflector based multi-party video conferencing tool

³Both systems use the ITU H.261 algorithm for video compression, which is designed for digital video-telephony, and is suited to typical Internet capacity, as well as being reasonably amenable to implementation at the sender side in software. As regards the receiver side, it is very straightforward to implement. The main difference between Internet implementations of H.261 and ISDN based ones is that Internet ones are typically in software, and do not employ the expensive H.221 framing protocol.

Mbone2 Second video feed and audio.

ReLaTe ReLaTe (Remote Language Teaching) demo.

ReLaTe Mbone display machine for main exhibition area

The ReLaTe machine was situated in the exhibit area, adjacent to the cafe. Originally, we planned to have two Ethernet interfaces, and connect to both networks. In normal use it received multicast traffic destined for the exhibit/cafe networks via a tunnel from Mbone1. In the end we reverted to using the Cisco to carry out local copying.

The Mbone1 and Mbone2 machines were situated in a translator booth, overlooking the main auditorium, with good a/v cabling access, next to a riser from the basement, where the cable plant and router arrived. They connected logically to the Mbone by a tunnel through the Cisco to BTnet, BT's commercial Internet service. From BTnet, we implemented two multicast tunnels to MCI and UCL.

Ethernet

The auditorium Ethernet was required to terminate in the translator booth area. We used *at least* four access points here.

In addition, Ethernet was provided to the Pickwick suite for the cafe and exhibit networks. The UCL exhibit was *originally* intended to be sited so that the ReLaTe machine connected to both cafe and exhibit networks. In the end, we separated the ReLaTe and Mbone machines onto their own network with the Cisco replicating packets to it from the Mbone tunnel machine on the transmission network.

Audio/Visual

UCL and NTT provided two video cameras each, one situated in room 1/32 and one in the Churchill gallery. Cables were provided by the conference center to connect these cameras to the machines in room 1/35, and to provide audio line level from the auditorium microphones via a mixer, and from the mbone workstations back to the auditorium PA system. In the end, we provided a PAL/NTSC scan-line convertor so that we could share nput from the Slide camera that UCL had. There was a lack of communication between the Mbone booth, and the location of the camera operators and the audio engineer's booth, which caused some problems. Wirelss communcation tools (radio/phone/IR links) would have made things far more efficient.

Other requirements

A telephone which accepts incoming calls, and can make international calls is required in room 1/35 for use by the Mbone team was essential. Not only could we reach WAN operational staff, but we could dial out to IP dialup sites, and thence test what was wrong when our network connectivity was down. Later, it transpired that we could even dial in to the NTT site with a laptop equipped with a 28.8kbps modem, and retrieve live video from there, and gan some idea of the quality being received at the remote site!

The appearance

Another view of the appearance

Lessons

There were a number of lessons that were gained during this operation, and we outline them in the following subsections, in a bottom up manner, starting with the link level, and going on up, approximately through the ISO OSI 7 layer model, as it were, until we reach the human factors levels.

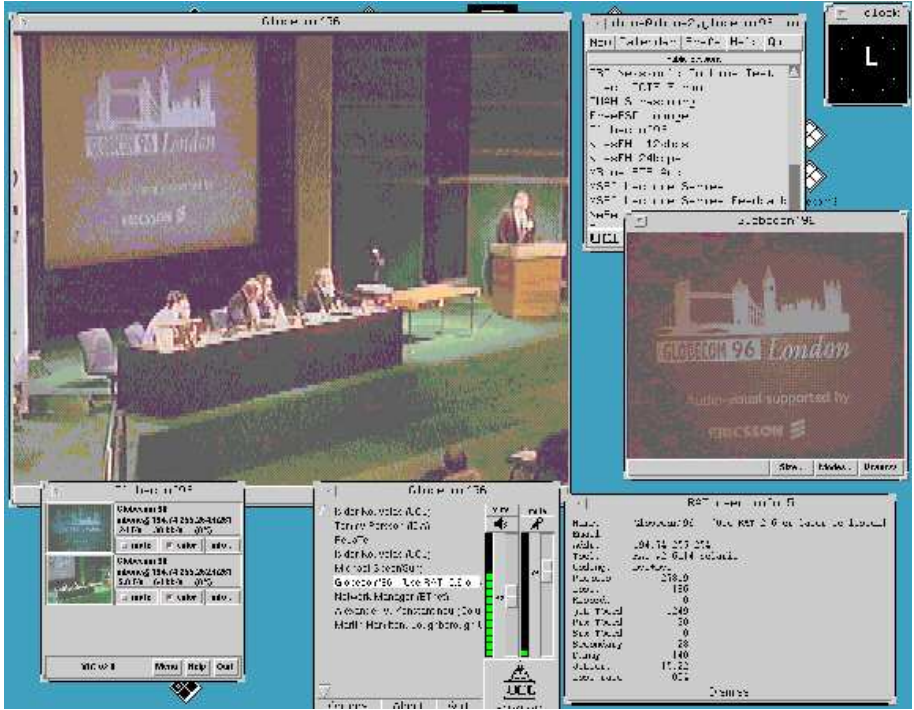

Figure 2: A Captured screen of a session

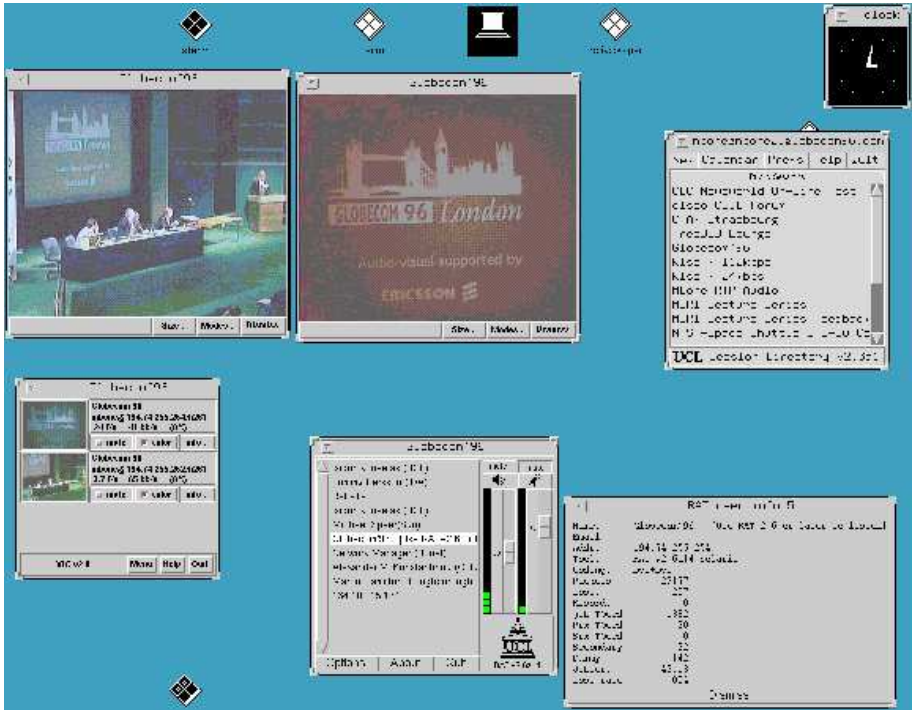

Figure 3: A second Captured screen of a session

Link Level

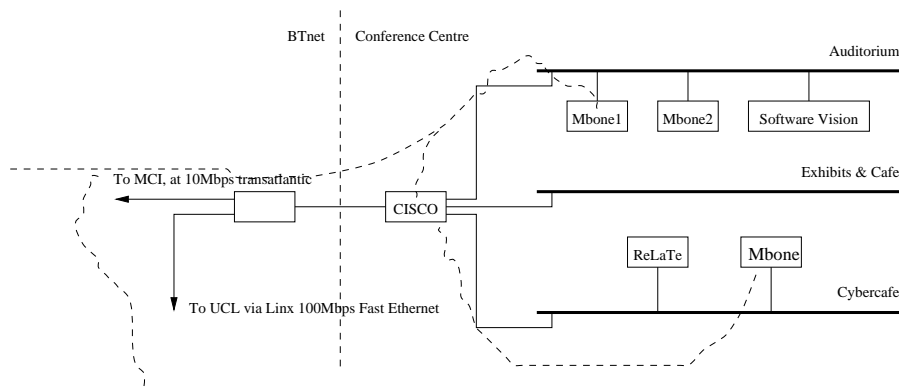

Figure 4: Actual Network Layout

The first thing we learned was that Local Area Network technology was very flexible and reliable. Despite changing our network design within the QEII center several times, the use of Ethernets, and particularly of mini-hubs, was highly successful, and flexible.

In the lesson for the wide area, we had the opposite lessons. Both for the links to and from the center, which were “Megastream” (E1, 2Mbps links), and for cross connectivity between the UK BTnet commercial service, and the UK academic networks which operate on SMDS switched networks, we encountered a variety of installation and configuration problems.

The key problem in both cases was that we had configured IP routes to use these, before establishing that the link-layer connectivity was indeed in place. This should be avoided whenever possible!

Onwards connectivity from the UK academic networks was provided over the pan-European ATM research network, JAMES, as part of access that UCL has for the Prospect and Merci projects, which involve multimedia conferencing for distance education. Since these had already been configured and tested as part of those projects, IP level connectivity for unicast and multicast was assured.

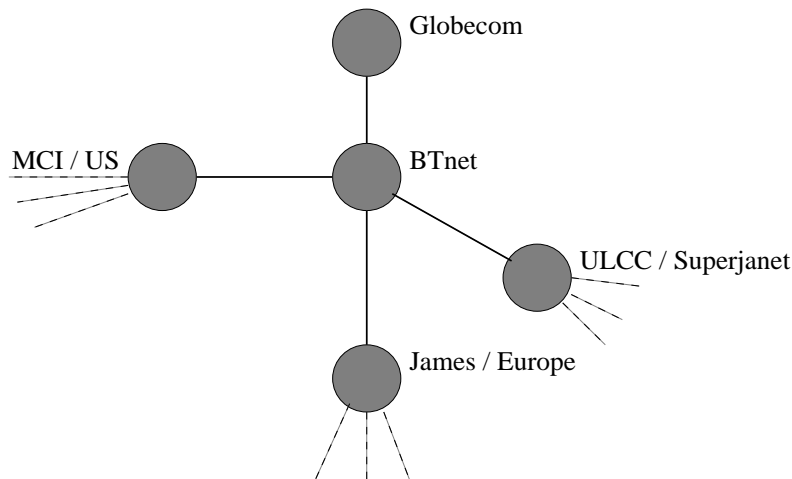

Figure 5: International Access

IP Level Routing, Unicast and Multicast

Always make sure you have all the Internet operational debugging tools installed on your exhibition and mbone machines:

For mbone topological and loss network debugging, mrimf for finding out which multicast tunnel routes are configured and mtrace for discovering the current topology, are essential. But before this comes into play, traceroute and ping are vital for tracking throughput/loss and connectivity problems, as well as access to routers. tcpdump or snoop or a similar packet sniffer are also all very useful. Better integration and more accurate mbone statistics would always be an improvement. It is not easy to trace out a multicast distribution tree to find a lossy link, for example. Telnet and E-mail are both also essential. The resulting topology is shown in figure 4, with the International links shown schematically in figure 5.

```
traceroute nms.expo96.ad.jp
traceroute to nms.expo96.ad.jp (133.246.192.11) 30 hops max, 40 byte
packets
 1 * cisco (128.16.6.150)  2 ms  3 ms
 2 128.40.14.245 (128.40.14.245)  2 ms  3 ms  3 ms
 3 cisco-c.ucl.ac.uk (128.40.20.253)  4 ms  53 ms  8 ms
 4 cisco-e.ucl.ac.uk (128.40.20.254)  4 ms (ttl=253!)  6 ms
(ttl=253!)  6 ms (ttl=253!)
 5 194.83.100.62 (194.83.100.62)  6 ms (ttl=252!)  5 ms (ttl=252!)  5
ms (ttl=252!)
 6 128.86.1.9 (128.86.1.9)  5 ms (ttl=251!)  6 ms (ttl=251!)  8 ms
(ttl=251!)
 7 sl-4.c36-11.New-York2.t3.ans.net (204.151.184.25)  174 ms
(ttl=250!)  171 ms (ttl=250!)  228 ms (ttl=250!)
 8 f2.t36-0.New-York2.t3.ans.net (140.223.36.221)  200 ms (ttl=249!)
* *
 9 hl2.t32-0.New-York.t3.ans.net (140.223.33.25)  167 ms (ttl=248!)
206 ms (ttl=248!)  171 ms (ttl=248!)
10 enss219.t3.ans.net (140.223.33.130)  180 ms (ttl=247!) *  224 ms
(ttl=247!)
11 mci.sprintnap.net (192.157.69.11)  269 ms (ttl=246!) *  242 ms
```

```
ping -vs nms.expo96.ad.jp
PING nms.expo96.ad.jp: 56 data bytes
64 bytes from nms.expo96.ad.jp (133.246.192.11): icmp_seq=0. time=426.
ms
64 bytes from nms.expo96.ad.jp (133.246.192.11): icmp_seq=1. time=558.
ms
64 bytes from nms.expo96.ad.jp (133.246.192.11): icmp_seq=2. time=326.
ms
64 bytes from nms.expo96.ad.jp (133.246.192.11): icmp_seq=3. time=336.
ms
^C
----nms.expo96.ad.jp PING Statistics----
5 packets transmitted, 4 packets received, 20% packet loss
round-trip (ms)  min/avg/max = 326/411/558
```

```
Mtrace from 194.74.255.252 to 128.40.64.6 via group 224.2.133.213
Querying full reverse path...
 0 jammu.avc.ucl.ac.uk (128.40.64.6)
-1 kashmir.avc.ucl.ac.uk (128.40.64.5)  DVMRP thresh^ 1
-2 mrouter.ucl.ac.uk (128.40.22.218)  DVMRP thresh^ 8
-3 noc2.ulcc.ja.net (193.63.94.26)  DVMRP thresh^ 24
-4 noc.ulcc.ja.net (193.63.94.25)  DVMRP thresh^ 1
-5 lea.cs.ucl.ac.uk (128.16.64.24)  DVMRP thresh^ 24
```

```

-6 sauce-atm.uio.no (129.240.202.82) DVMRP thresh^ 32
-7 stockholm.mbone.ebone.net (192.36.148.206) DVMRP thresh^ 40
-8 schnell.ebone.net (198.67.134.250) DVMRP thresh^ 64
-9 dec3800-1-fddi-0.WestOrange.mci.net (204.70.64.29) DVMRP thresh^ 32
-10 dec3800-2-fddi-1.WestOrange.mci.net (204.70.64.77) DVMRP thresh^ 1
-11 news-feed2.bt.net (194.72.7.122) DVMRP thresh^ 64
-12 ? (194.74.255.254) DVMRP thresh^ 24
-13 ? (194.74.255.252)
Round trip time 274 ms

```

Waiting to accumulate statistics... Results after 10 seconds:

Source	Response Dest	Packet Statistics For	Only For Traffic
194.74.255.252	128.40.64.6	All Multicast Traffic	From 194.74.255.252
v	___/ rtt 253 ms	Lost/Sent = Pct Rate	To 224.2.133.213
194.74.255.254	?		
v	^ ttl 24	5/418 = 1% 41 pps	0/95 = 0% 9 pps
194.72.7.122	news-feed2.bt.net		
v	^ ttl 64	1/309 = 0% 30 pps	0/95 = 0% 9 pps
204.70.64.77	dec3800-2-fddi-1.WestOrange.mci.net		
v	^ ttl 65	1/1154 = 0% 0 pps	0/95 = 0% 0 pps
204.70.64.45			
204.70.64.29	dec3800-1-fddi-0.WestOrange.mci.net		
v	^ ttl 66	1/352 = 0% 0 pps	0/95 = 0% 0 pps
198.67.134.250	schnell.ebone.net		
v	^ ttl 67	-3/1175 = 0% 117 pps	0/95 = 0% 9 pps
192.36.148.206	stockholm.mbone.ebone.net		
v	^ ttl 68	116/1442 = 8% 144 pps	7/95 = 7% 9 pps
129.240.202.42			
129.240.202.82	sauce-atm.uio.no		
v	^ ttl 69	-3/1487 = 0% 148 pps	0/88 = 0% 8 pps
128.16.48.10			
128.16.64.24	lea.cs.ucl.ac.uk		
v	^ ttl 70	758/1729 = 44% 172 pps	25/88 = 28% 8 pps
193.63.94.25	noc.ulcc.ja.net		
v	^ ttl 71	-29/973 = -2% 97 pps	0/63 = 0% 6 pps
193.63.94.26	noc2.ulcc.ja.net		
v	^ ttl 72	-1/277 = 0% 27 pps	0/63 = 0% 6
ppsl28.40.22.218	mrouter.ucl.ac.uk		
v	^ ttl 73	0/229 = 0% 22 pps	0/63 = 0% 6 pps
128.40.64.5	kashmir.avc.ucl.ac.uk		
v	___ ttl 74	230 23 pps	63 6 pps
128.40.64.6	128.40.64.6		
Receiver	Query Source		

Mtrace from 194.74.255.254 to 128.40.64.6 via group 224.2.133.213
Querying full reverse path...

```

0 jammu.avc.ucl.ac.uk (128.40.64.6)
-1 kashmir.avc.ucl.ac.uk (128.40.64.5) DVMRP thresh^ 1
-2 mrouter.ucl.ac.uk (128.40.22.218) DVMRP thresh^ 8
-3 noc2.ulcc.ja.net (193.63.94.26) DVMRP thresh^ 24
-4 noc.ulcc.ja.net (193.63.94.25) DVMRP thresh^ 1
-5 lea.cs.ucl.ac.uk (128.16.64.24) DVMRP thresh^ 24
-6 laphroaig.cs.ucl.ac.uk (128.16.64.4) DVMRP thresh^ 1

```

```

-7 news-feed2.bt.net (194.72.7.122) DVMRP thresh^ 24
-8 ? (194.74.255.254) DVMRP thresh^ 24
-9 ? (194.74.255.254)
Round trip time 106 ms

```

Waiting to accumulate statistics... Results after 10 seconds:

Source	Response	Dest	Packet	Statistics For	Only For Traffic
194.74.255.254	128.40.64.6		All Multicast	Traffic	From 194.74.255.254
v	___/ rtt	87 ms	Lost/Sent =	Pct Rate	To 224.2.133.213
194.74.255.254	?				
v	^	ttl 24	12/661 =	2% 66 pps	4/81 = 5% 8 pps
194.72.7.122	news-feed2.bt.net				
v	^	ttl 25	2/1806 =	0% 180 pps	0/77 = 0% 7 pps
193.63.58.2					
128.16.64.4	laphroaig.cs.ucl.ac.uk				
v	^	ttl 26	-208/1814 =	-10% 181 pps	0/77 = 0% 7 pps
128.16.64.24	lea.cs.ucl.ac.uk				
v	^	ttl 27	1608/2721 =	59% 272 pps	34/77 = 44% 7 pps
193.63.94.25	noc.ulcc.ja.net				
v	^	ttl 28	-312/1113 =	-27% 111 pps	0/43 = 0% 4 pps
193.63.94.26	noc2.ulcc.ja.net				
v	^	ttl 29	0/251 =	0% 25 pps	0/43 = 0% 4 pps
128.40.22.218	mrouter.ucl.ac.uk				
v	^	ttl 30	0/185 =	0% 18 pps	0/43 = 0% 4 pps
128.40.64.5	kashmir.avc.ucl.ac.uk				
v	__	ttl 31	179	17 pps	43 4 pps
128.40.64.6	128.40.64.6				
Receiver	Query Source				

```

/usr/multicast/mtrace 194.74.255.254 224.2.199.104
Mtrace from 194.74.255.254 to 132.146.196.31 via group 224.2.199.104
Querying full reverse path...
0 gideon (132.146.196.31)
-1 host254.bt-sys.bt.co.uk (132.146.196.254) PIM thresh^ 0
-2 pitt.futures.bt.co.uk (132.146.111.251) DVMRP thresh^ 0
-3 noc.thouse.ja.net (193.62.157.234) DVMRP thresh^ 24
-4 mbone.ulcc.ja.net (193.63.94.99) DVMRP thresh^ 24
-5 noc.ulcc.ja.net (193.63.94.25) DVMRP thresh^ 1
-6 lea.cs.ucl.ac.uk (128.16.64.24) DVMRP thresh^ 24
-7 sauce-atm.uio.no (129.240.202.82) DVMRP thresh^ 32
-8 stockholm.mbone.ebone.net (192.36.148.206) DVMRP thresh^ 40
-9 schnell.ebone.net (198.67.134.250) DVMRP thresh^ 64
-10 dec3800-1-fddi-0.WestOrange.mci.net (204.70.64.29) DVMRP thresh^ 32
-11 dec3800-2-fddi-1.WestOrange.mci.net (204.70.64.77) DVMRP thresh^ 1
-12 news-feed2.bt.net (194.72.7.122) DVMRP thresh^ 64
-13 ? (194.74.255.254) DVMRP thresh^ 24
-14 ? (194.74.255.254)
Round trip time 328 ms

```

* Results after 52 seconds:

Source	Response	Dest	Packet	Statistics For	Only For
--------	----------	------	--------	----------------	----------

```

Traffic
194.74.255.254 132.146.196.31 All Multicast Traffic From
194.74.255.254
v ___/ rtt 224 ms Lost/Sent = Pct Rate To
224.2.199.104
194.74.255.254 ?
v ^ ttl 24 0/2041 = 0% 39 pps 0/621 = 0%
11 pps
194.72.7.122 news-feed2.bt.net
v ^ ttl 64 -2/2048 = 0% 39 pps -1/621 = 0%
11 pps
204.70.64.77 dec3800-2-fddi-1.WestOrange.mci.net
v ^ ttl 65 9/6813 = 0% 6 pps 2/622 = 0%
0 pps
204.70.64.45
204.70.64.29 dec3800-1-fddi-0.WestOrange.mci.net
v ^ ttl 66 11/2279 = 0% 2 pps 1/620 = 0%
0 pps
198.67.134.250 schnell.ebone.net
v ^ ttl 67 11/8473 = 0% 162 pps 0/619 = 0%
11 pps
192.36.148.206 stockholm.mbone.ebone.net
v ^ ttl 68 1027/10457= 10% 201 pps 56/619 = 9%
11 pps
129.240.202.42
129.240.202.82 sauce-atm.uio.no
v ^ ttl 69 976/9501 = 10% 182 pps 41/563 = 7%
10 pps
128.16.48.10
128.16.64.24 lea.cs.ucl.ac.uk
v ^ ttl 70 6917/12726= 54% 244 pps 230/522 = 44%
10 pps
193.63.94.25 noc.ulcc.ja.net
v ^ ttl 71 259/5809 = 4% 111 pps 0/292 = 0%
5 pps
193.63.94.99 mbone.ulcc.ja.net
v ^ ttl 72 1/4678 = 0% 89 pps 0/292 = 0%
5 pps
193.62.157.234 noc.thouse.ja.net
v ^ ttl 73 1096/3165 = 35% 60 pps 2/292 = 1%
5 pps
132.146.110.222
132.146.111.251 pitt.futures.bt.co.uk
v ^ ttl 74 1708/3371 = 51% 64 pps 0/290 = 0%
5 pps
132.146.111.254
132.146.196.254 host254.bt-sys.bt.co.uk
v \_ ttl 75 1634 31 pps 290
5 pps
132.146.196.31 132.146.196.31
Receiver Query Source

```

Transport Level - RTP and TCP Performance

The transport layer protocol used for traditional Internet applications is TCP. However, for multimedia conferencing, especially for Multi-party delivery, the appropriate protocols are RTP/RTCP over UDP. UDP is connectionless, and does not attempt to recover from lost packets by any hop-by-hop or end-to-end means, unlike TCP. This avoids the non-deterministic delays and *stalling* effects due to retransmissions after loss and timeout in TCP. It does so at the expense of degradation of picture or speech quality, but given loss is constrained to a reasonable level (less than 50% typically), audio and video coding schemes, and receiver tools can be designed to accommodate this without too much perceived loss of quality by the user.

RTP (the slightly misleadingly named Realtime Transport Protocol) is simply a framing protocol for the media, while RTCP (Realtime Transport Control Protocol) is a statistics reporting protocol used to coordinate membership and traffic conditions within a multi-party conference. It is important to note how useful RTCP is for debugging quality problems at the network and link layers.

The Applications

The applications that we used were the tools from UCL and LBL, namely Sdr, the Session Directory tool, which lists all Mbone events, Rat, the Robust-Audio Tool, Vic, the LBL Video Conferencing program and Wb the LBL Whiteboard, which is heavily used to provide feedback between participants.

The NTT tools were the SoftwareVision packages, with hardware assist for coding, but pure software reception. These tools are available from the network, from the sites are given in the references at the end.

Audio/Visual

We were very fortunate in having direct assistance from the audio-visual company at the QEII (the appropriately named "Interface") They ensured that we had a direct line-level studio quality audio feed to and from the PA and microphones in the main auditorium, as well as providing remote cabling for access between our cameras in the auditorium, and our computer equipment in the booth.

It is worth noting that a lot of computing audio equipment has "less than professional quality" analog audio input/output, so that typically, injecting audio output from a computer system (even a Sun or SGI workstation) to a large PA sometimes generates unexpected levels of background noise. We were fairly lucky in this respect in that the systems we happened to use were, purely by chance, not too noisy.

An important aspect of "Mboning" a large event is the choice of cameras - you need to be able to zoom in on speakers. We had one studio quality camera for capturing slides, but the other cameras we used were domestic camcorder variety - these were adequate. but only just.

Human level Staffing

Good knowledge of IP, Ethernet, Unix and Windows, as well as router configuration, and good contact information is essential. Phones (even Cell phones) and personal organisers are useful to trouble shoot things quickly.

Acknowledgements

Many thanks are due to Peter Ingram and David Pratt of BT for help with coordination and router configuration. The staff at UCL's Information Systems Division, and the University of London Computer Center at the Networks Operations Center, and UCL CS helped to debug Internet multicast routing and SMDS interworking problems. Nigel Titley at BTnet helped coordinate the QEII/BT/MCI connectivity.

SoftwareVision is available from <http://www.hil.ntt.jp/SoftwareVision/index-e.html> whilst the Mbone tools can be retrieved from <http://ugwww.ucs.ed.ac.uk/mice/archive/>.

Finally, thanks are due to the UCL Merci project, project 1007, funded under the EC Telematics programme.

Bibliography

References

- [1] "Frequently Asked Questions (FAQ) on the Multicast Backbone (MBONE)" <http://www-mice.cs.ucl.ac.uk/mice/faq.html> Steve Casner
- [2] "A Scalable Video Distribution Technique for the Internet" Hiroshi Jinzenji, Hisashi Kasahara, Kazunori Shimamura NTT Laboratories Presented at the Work in Progress Session, IEEE Globecom Internet '96 Conference, London, Nov 1996.
- [3] "Sharing the Cost of Multicast Trees: An Axiomatic Analysis" Shai Herzog, Deborah Estrin, Scott Shenker in ACM SIGCOMM 95, Vol 25, No. 4, pp 315-327 Cambridge Mass, Sep 1995.
- [4] 1889 RFC H. Schulzrinne, S. Casner, R. Frederick, V. Jacobson, "RTP: A Transport Protocol for Real-Time Applications", 01/25/1996