



---

# Mobile and Sensor Systems

## Lecture 7: Sensor Networking Routing

**Dr. Cecilia Mascolo**

# What's on this Lecture

---



- We will discuss network layer protocols for sensor networks
- Also we will talk about data gathering and aggregation

# Network Protocols



- Can we apply ad hoc networks protocols?
- Yes protocols like epidemic can be applied but overhead is an issue
- Aims are usually different: not communication but data reporting to single or multiple source
  
- Specific protocols have been devised
- Specific nodes are interested in specific events
  - Sink interested in all results
  - Sink interested in a sensor reading change

# Protocols for Repeated interactions

---



- Subscribe once, events happen multiple times
    - Exploring the network topology might actually pay off
    - But: unknown which node can provide data, multiple nodes might ask for data
      - ! How to map this onto a “routing” problem?
  - Idea: Put enough information into the network so that publications and subscriptions can be mapped onto each other
    - But try to avoid using unique identifiers: might not be available, might require too big a state size in intermediate nodes
- ! ***Directed diffusion*** as one option for implementation
- Try to rely only on ***local interactions*** for implementation

# Directed Diffusion



- Data-centric approach
- Nodes send “interests” for data which are diffused in the network
- Sensors produce data which is routed according to interests
- Intermediate nodes can filter/aggregate data

# Interest Propagation



- Each sink sends expression of interests to neighbours
- Each node will store interests and disseminate those further to their neighbours.
  - Cache of interest is checked not to repeat disseminations
- Interests need refreshing from the sink [they time out]
- Interests have a “rate of events” which is defined as “**gradient**”

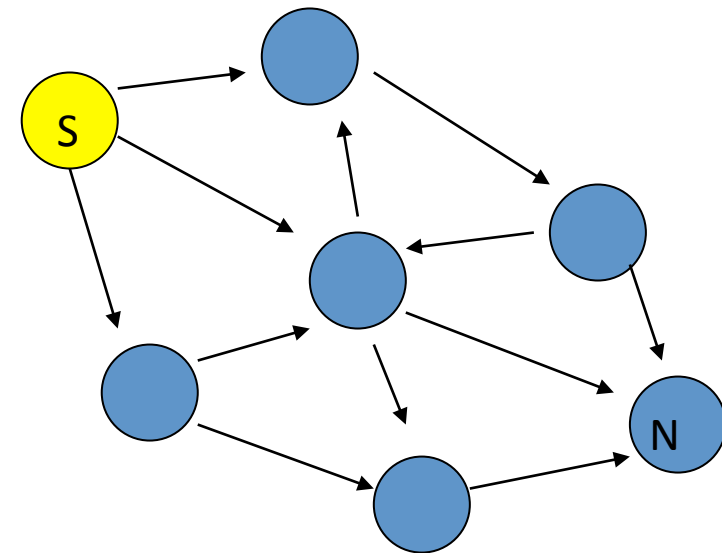

# Data delivery



- Sensor data sources emit events which are sent to neighbours according to interest [ie if there is a gradient]
- Each intermediate node sends back data at a rate which depends on the gradient
  - Ie if gradient is 1 event per second and 2 events per second are received send either the first or a combination of the two [aggregation]
- Events are stored to avoid cycles [check if same event received before]
- Data can reach a node through different paths. Gradient enforcement needed

# Gradients Reinforcement



- When gradients are established the rate is defined provisionally [usually low]
- Sinks will ‘reinforce’ good paths which will be followed with higher rate
- A path expires after a timeout so if not reinforced it will cease to exist
  - This allows adaptation to changes and failures



# Directed diffusion – Two-phase pull



- **Phase 1:** nodes distribute *interests* in certain kinds of named data
  - Specified as attribute-value pairs
- Interests are flooded in the network
  - Apparently obvious solution: remember from where interests came, set up a “tree”
  - Problem: Node X cannot distinguish, in absence of unique identifiers, between the two situations on the right – set up only one or three trees?

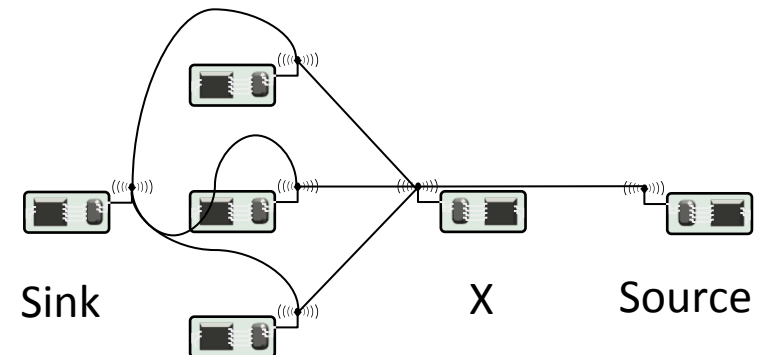
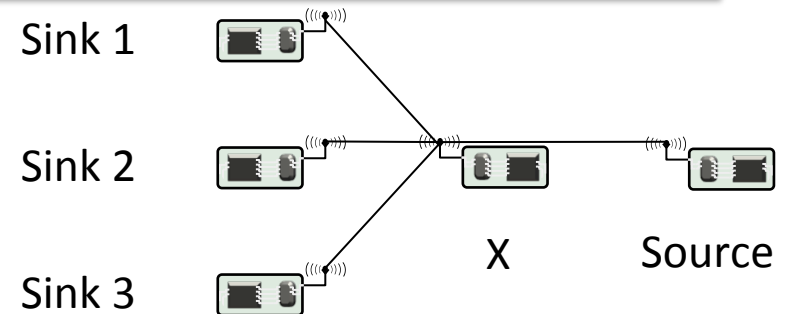

# Direction diffusion – Gradients in two-phase pull

---



- Option 1: Node X forwarding received data to all “parents” in a “tree”
  - Not attractive, many needless packet repetitions over multiple routes
- Option 2: node X only forwards to one parent
  - Not acceptable, data sinks might miss events
- Option 3: Only provisionally send data to all parents, but ask data sinks to help in selecting which paths are redundant, which are needed
  - Information from where an interest came is called ***gradient***
  - Forward all published data along all existing gradients

# Directed diffusion – extensions

---



- Problem: Interests are flooded through the network
- Geographic scoping & directed diffusion
  - Interest in data from specific areas should be sent to sources in specific geo locations only
- Push diffusion – few senders, many receivers
  - Same interface/naming concept, but different routing protocol
  - Here: do not flood interests, but flood the (relatively few) data
  - Interested nodes will start reinforcing the gradients

# Issues



- Purely theoretical work
- A part from the flooding of the interests...
- No consideration of real world issues such as link stability or link load and load dependence
- Mac Layer issues (assume nodes are awake...or does not discuss it)
- More recent approaches have considered link capabilities as part of the routing decision making

# Data aggregation



- Less packets transmitted -> less energy used
- To still transmit data, packets need to combine their data into fewer packets ! **aggregation** is needed
- Depending on network, aggregation can be useful or pointless
- Directed diffusion gradient might require some data aggregation

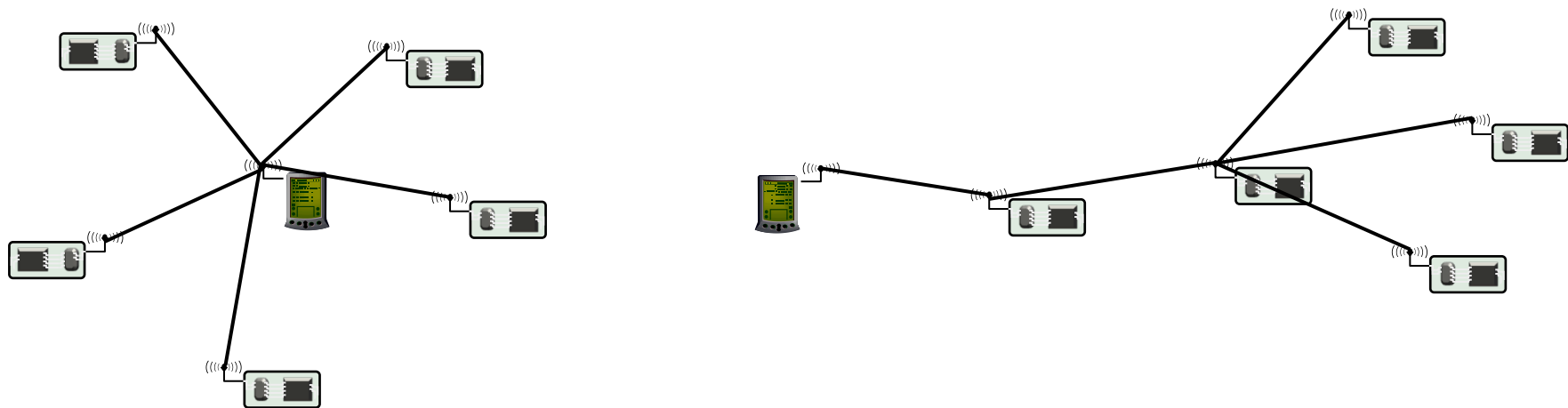

# Metrics for data aggregation

---



- **Accuracy:** Difference between value(s) the sink obtains from aggregated packets and from the actual value (obtained in case no aggregation/no faults occur)
- **Completeness:** Percentage of all readings included in computing the final aggregate at the sink
- **Latency**
- **Message overhead**

# Link quality based routing



- Directed diffusion uses some sort of implicit ways to indicate which are the good links
  - Through the gradient
- Ad hoc routing protocols for mobile networks route messages based on shorter path in terms of number of hops
- The essence of the next protocol we present: “number of hops might not be the best performance indication in wireless sensor network”

# Routing based on Link Estimation



- Routing algorithms should take into account underlying network factors and under realistic loads.
- Link connectivity in reality is not spherical as often assumed

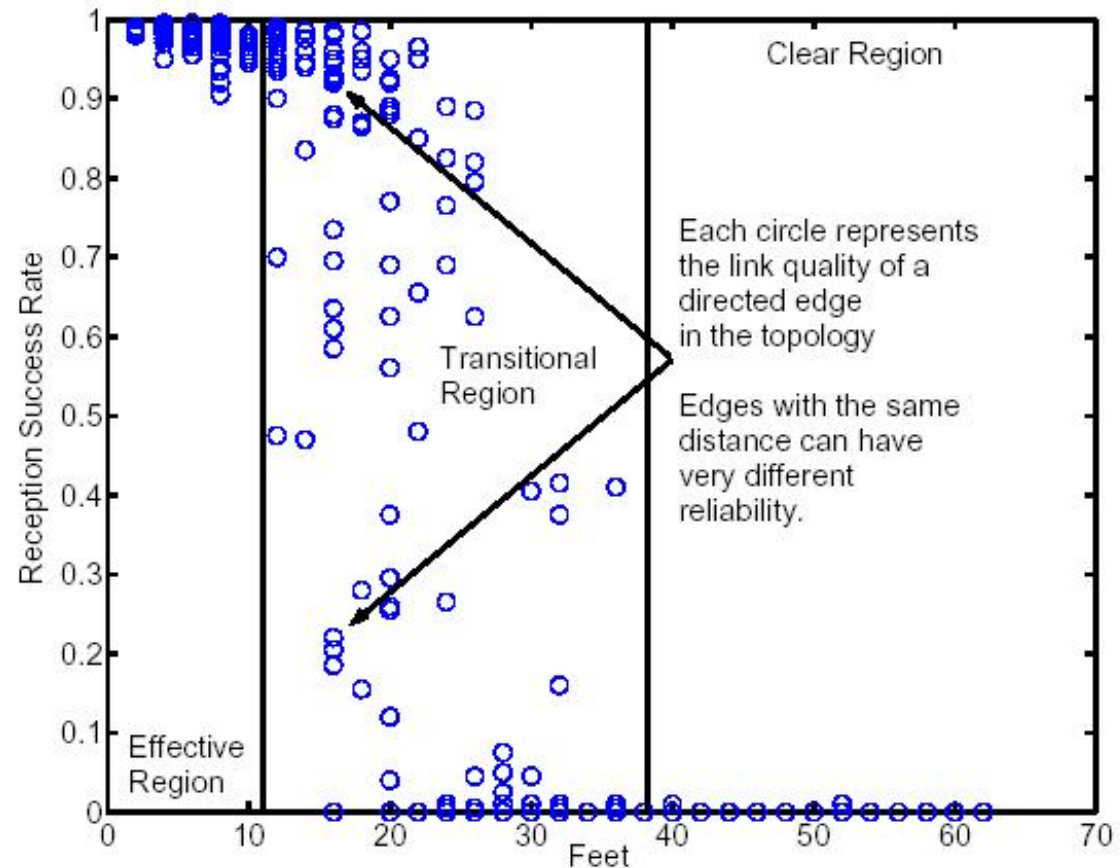



# Link Estimation



- A good estimator in this setting must
  - Be stable
  - Be simple to compute and have a low memory footprint
  - React quickly to large changes in quality
  - Neighbour broadcast can be used to passively estimate

# WMEWMA

---



- Snooping
  - Track the sequence numbers of the packets from each source to infer losses
- Window mean with EWMA
  - $MA(t) = (\text{\#packets received in } t) / \text{max}(\text{\#packets expected in } t, \text{packets received in } t)$
  - $EWMA(t_x) = a (MA(t_x)) + (a-1)EWMA(t_{(x-1)})$
  - $t_x$  : last time interval;  $a$ : weight

# WMEWA ( $t = 30, a = 0.6$ )

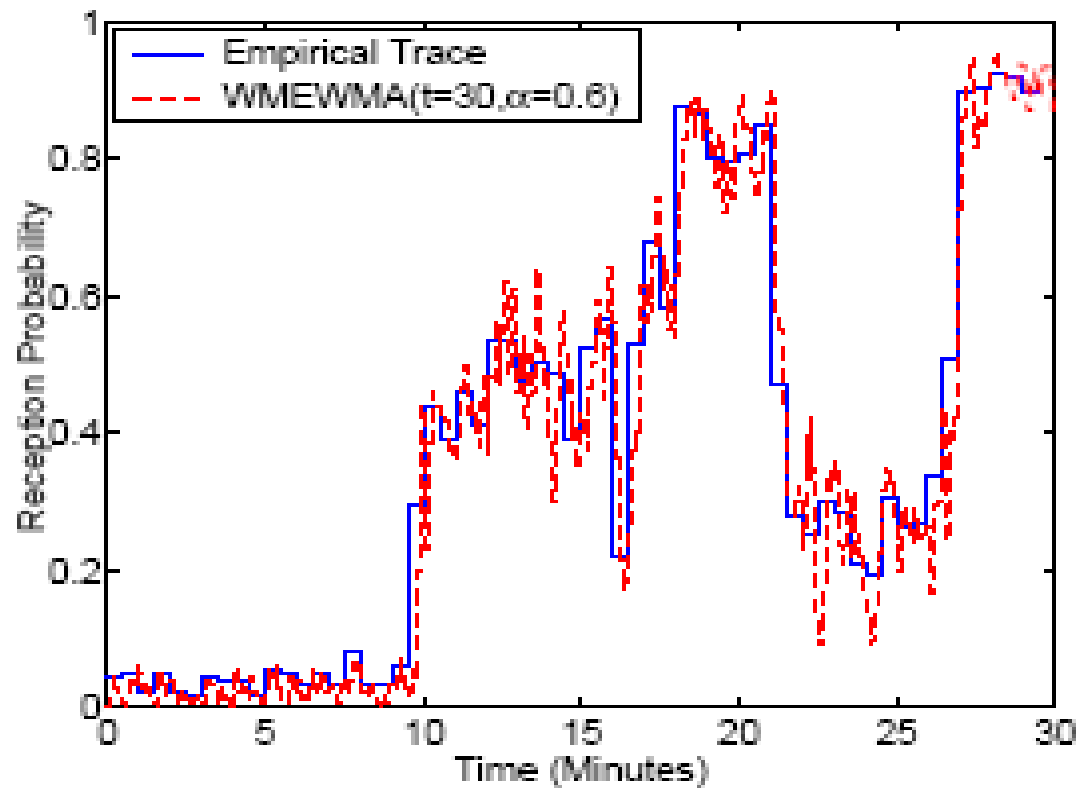

# Neighborhood Management



- Neighborhood table
  - Record information about nodes from which it receives packets (also through snooping)
- If network is dense, how does a node determine which nodes it should keep in the table?
- Keep a sufficient number of good neighbours in the table
- Similar to cache management for packet classes

# Link Estimation based Routing

---



- Focus on “many to one” routing model
  - Information flows one way
- Estimates of inbound links are maintained, however outbound links need to be used!
  - Propagation back to neighbours
- Each node selects a parent [using the link estimation table]
  - Changes when link deteriorates (periodically)

# Distance vector routing: cost metrics

---



- Routing works as a standard distance vector routing
- The DVR cost metric is usually the hop count
- In lossy networks hop count might underestimate costs
  - Retransmissions on bad links: shortest path with bad links might be worse than longer path with good links
  - Solution: consider the cost of retransmission on the whole path

# MIN-T



- MT (Minimum Transmission) metric:
  - Expected number of transmissions along the path
  - For each link, MT cost is estimated by
$$1/(\text{Forward link quality}) * 1/(\text{Backward link quality})$$
    - backward links are important for acks
- Use DVR with the usual hop counts and MT weights on links

# En Example

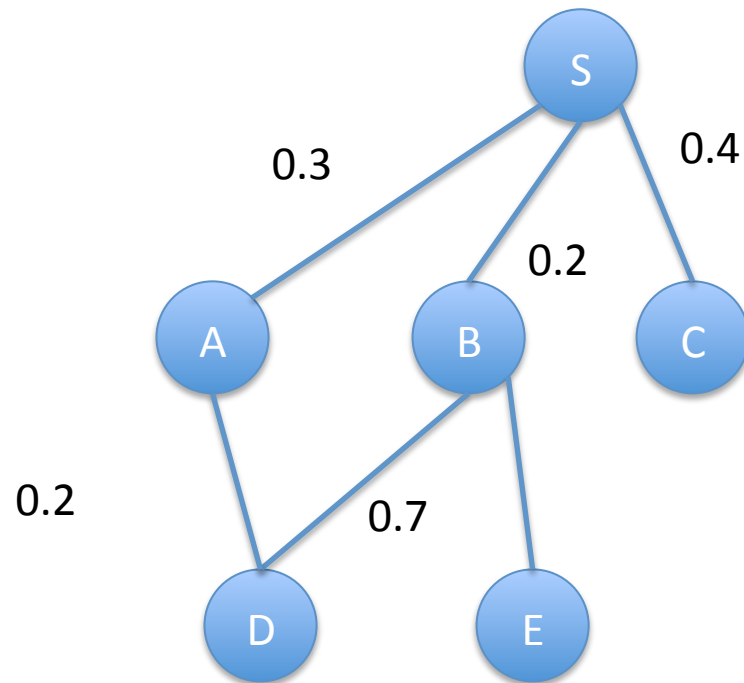

Routing Table on D:

Id	Cost	NextHop
----	------	---------

A	0.2	A
---	-----	---

B	0.7	B
---	-----	---

S	0.5	A
---	-----	---



# References



- Intanagonwiwat, C., Govindan, R., and Estrin, D. 2000. Directed diffusion: a scalable and robust communication paradigm for sensor networks. In Proceedings of the 6th Annual international Conference on Mobile Computing and Networking (Boston, Massachusetts, United States, August 06 - 11, 2000). MobiCom '00. ACM, New York, NY, 56-67.
- Woo, A., Tong, T., and Culler, D. 2003. Taming the underlying challenges of reliable multihop routing in sensor networks. In *Proceedings of the 1st international Conference on Embedded Networked Sensor Systems* (Los Angeles, California, USA, November 05 - 07, 2003). SenSys '03. ACM, New York, NY. Pages: 14-27.

# Summary

---



- We have discussed various routing protocols for sensor networks
- We have shown that it makes sense to consider link quality based metrics in wireless sensor network routing