

COMPUTER SCIENCE TRIPOS Part IA

Tuesday 7 June 2005 1.30 to 4.30

Paper 2

*Answer the question in Section A, **one** question from each of Sections B and C, and **two** questions from Section D.*

*Submit the answers in five **separate** bundles, each with its own cover sheet. On each cover sheet, write the numbers of **all** attempted questions, and circle the number of the question attached.*

**You may not start to read the questions
printed on the subsequent pages of this
question paper until instructed that you
may do so by the Invigilator**

STATIONERY REQUIREMENTS

Script Paper

Blue Coversheets

Tags

SECTION A**1 Multi-part question**

Answer all parts.

- (a) A one megabyte memory bank with 64-bit data bus is to be constructed from SRAM chips of individual capacity $32\text{K}\times 8$. Sketch out a design for the bank showing clearly how the SRAM chips are arranged. [4 marks]
- (b) Describe, in 30–40 words each, *three* ways in which an underlying theory can help to improve the quality of software systems. [4 marks]
- (c) Acoustic couplers used to connect modems to telephone handsets present an audio interface from the telephone network to computer equipment. Name *one* advantage and *one* disadvantage of using such an interface. [4 marks]
- (d) Show that for any two regular expressions r and s , the regular expressions $r(sr)^*$ and $(rs)^*r$ determine the same regular language. [4 marks]
- (e) Describe a significant invention in software engineering, including the problem it addresses and the manner in which it is supported by modern development tools. [4 marks]

SECTION B

2 Digital Electronics

- (a) A Moore machine is required which produces the counting sequence 0,1,2,3,4,5,0. Give a minimum sum-of-products for each of the next state variables for an implementation of this Moore machine. [6 marks]
- (b) Design a two-bit Gray code counter which produces the binary sequence 00,01,11,10,00. The counter should be designed as a Moore machine consisting of D flip-flops (with enable inputs) and a minimal number of logic gates. An additional input (E) is required to enable or disable counting which can be connected directly to the enable inputs of the D flip-flops. What is the final circuit diagram? [6 marks]
- (c) The 0→5 and Gray-code counters are coupled together to produce a state machine with following state sequence and output pattern in Morse code for SOS ($\dots - - - \dots$):

State sequence		Output
00	000	0
00	001	1
00	010	0
00	011	1
00	100	0
00	101	1
01	000	0
01	001	1
01	010	1
01	011	1
01	100	0
01	101	1
11	000	1
11	001	1
11	010	0
11	011	1
11	100	1
11	101	1
10	000	0
10	001	1
10	010	0
10	011	1
10	100	0
10	101	1

With the aid of a circuit diagram, explain how the two counters are coupled together to produce the sequencer, and how the required Morse code output can be generated from this sequencer. [8 marks]

3 Digital Electronics

The “Wacky Flip-Flops Company” has sent you the following datasheet with schematics of their latest flip-flops. For each flip-flop, determine the truth table, label the inputs and outputs (e.g. “input U is the clock”) and name the flip-flop (e.g. “it is a T-type flip-flop”).

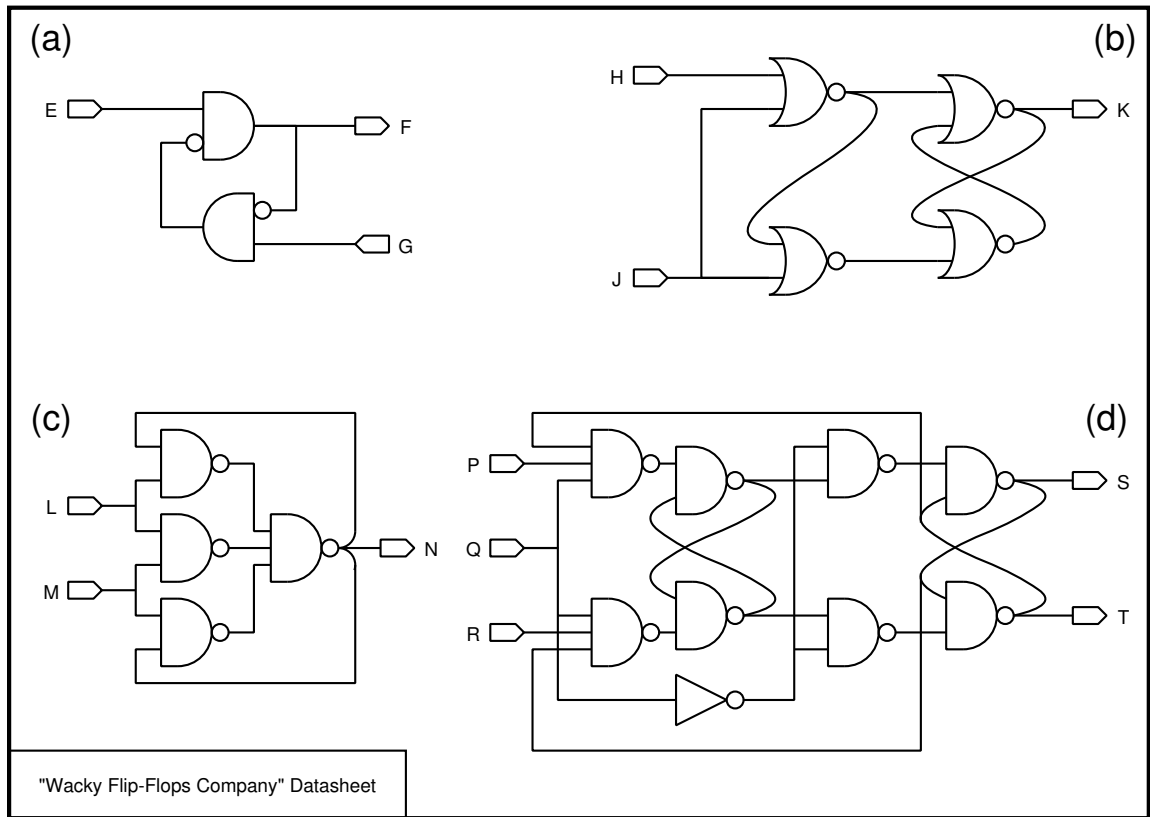

[5 marks each]

SECTION C

4 Probability

- (a) Given a random variable X distributed Geometric(p) one has:

$$P(X = r) = q^r p \quad \text{where} \quad p + q = 1$$

By using a suitable generating function, derive expressions for the expectation and variance of X . [6 marks]

- (b) A computer game proceeds in a sequence of steps and, at each step, the contents of a two-bit random number generator are inspected. Each bit is 1 with probability p and 0 with probability q where $p + q = 1$. The two bits are independent.

If the two bits differ (as 01 or 10) the game ends but if the two bits are the same (as 00 or 11) the game proceeds to another step. Accordingly, the game could be as short as a single step but it could last many steps.

Let X be a random variable whose value r is the length of a game measured in steps. The game cannot end at step 0 so $P(X = 0) = 0$.

- (i) Derive an expression for $P(X = r)$. [5 marks]

- (ii) Show that $\sum_{r=0}^{\infty} P(X = r) = 1$. [4 marks]

- (iii) Derive an expression for the expected length of a game measured in steps. [5 marks]

5 Probability

By repeatedly dropping a knitting needle onto a floor constructed from parallel-sided floor boards one may estimate the value of π .

Suppose the needle has unit length and the boards have unit width. After each drop the position of the needle may be specified by the values of two independent random variables:

θ is the (acute) angle that the needle makes with the joints of the boards and it may be assumed that θ is distributed $\text{Uniform}(0, \frac{\pi}{2})$. [It is not necessary to consider values of θ in the other three quadrants.]

y is the distance of the centre of the needle from the nearest joint between two boards and it may be assumed that y is distributed $\text{Uniform}(-\frac{1}{2}, +\frac{1}{2})$.

- (a) Sketch sufficient of the θ - y plane to show the whole of the region R which corresponds to the needle crossing a joint. Deem such a crossing to be a *hit* and show that the probability of a *hit* is $2/\pi$ and, therefore, the value of π may be estimated experimentally by the formula $2 \times \text{drops}/\text{hits}$. [8 marks]
- (b) Suppose the needle is dropped n times. Let X be a random variable whose value is the number of *hits*. X is distributed $\text{Binomial}(n, 2/\pi)$. Give expressions for the Expectation $E(X)$ and the Variance $V(X)$. [2 marks]
- (c) Let $\pi_e(n)$ denote the estimated value of π when the number of *hits* is two standard deviations *below* the mean. Show that for

$$\pi_e(n) < \pi + 0.1$$

to hold, the number of *drops* n must be such that

$$n > \frac{2(\pi - 2)(\pi + 0.1)^2}{0.01}$$

[10 marks]

SECTION D

6 Professional Practice and Ethics

- (a) What is the defining characteristic of consequentialist theories in ethics? How can consequentialist theories differ? Identify at least *two* problems with consequentialist theories. [4 marks]
- (b) Give at least *three* functions of professional organisations and say why these functions are managed by the professional organisation (rather than some other organisation such as the government or universities). [6 marks]
- (c) Name *two* possible health problems that may arise in the IT industry and how they can be averted. [4 marks]
- (d) Give *one* good reason why it is (or why it is *not*) reasonable to require members of a professional body to report back to the professional body significant violations of professional conduct on the part of another member. [1 mark]
- (e) In addition to technical measures (passwords, encryption etc.) what more do organisations have to do to maintain information security? [2 marks]
- (f) Under the Data Protection Act, are your rights violated if an organisation (e.g. your college) gains access to your e-mail, prints it out and distributes it to members of staff? [1 mark]
- (g) What are the two main kinds of law that are used to provide intellectual property protection for software? [2 marks]

7 Software Engineering I

A car manufacturer wishes to save weight and improve reliability by replacing most of the vehicle's wiring harness with a local area network. Systems such as engine management, anti-lock braking, traction control and stability control will thus share common platform components. Your task is to ensure that the safety of these systems, and of the vehicle electronics overall, is not impaired by this upgrade.

- (a) Describe the methodology you would adopt for the project, and justify your choice. [10 marks]
- (b) How would you then ensure that subsequent development of these subsystems – which you should assume are supplied by different subcontractors – does not compromise vehicle safety? [10 marks]

8 Software Engineering II

You are asked to design a new product – a speed and distance computer to be mounted on the handlebars of a bicycle. The hardware includes two control pushbuttons, an LCD screen and a rotation sensor on the bicycle wheel. The device will have three normal operating modes: display of the current speed and distance travelled today; a graph of distance travelled on each day of the week; and a graph of average speed plotted against day of the week. It will be powered by stored energy from the rotation sensor. As stored energy becomes depleted, power management functions should first save data to non-volatile memory, then turn off the screen, and as a last resort shut down clock functions.

- (a) Draw preliminary diagrammatic software design models (i.e. not complete designs) suitable for:
- (i) presenting functionality to a potential customer;
 - (ii) planning data storage and manipulation;
 - (iii) analysing power management modes; and
 - (iv) defining the procedure for plotting the speed graph. [3 marks each]
- (b) For *each* of these models, name a different technique that could be used to verify that it is correct. [4 marks]
- (c) For part (a)(iv) only, suggest good names for *four* variables that would be used in implementing the procedure, indicating what rôle each variable plays. [4 marks]

9 Regular Languages and Finite Automata

- (a) Languages L_1, L_2 over alphabets Σ_1, Σ_2 are accepted by deterministic finite automata M_1, M_2 . Show how to construct a deterministic finite automaton M from M_1 and M_2 that accepts the intersection $L_1 \cap L_2$ of the two languages. What happens if M_1 and M_2 are non-deterministic? [10 marks]
- (b) A context-free grammar has a set of terminals $\{0, 1, -\}$, a set of non-terminals $\{N, P\}$, where N is the start symbol, and productions given by the following BNF.

$$\begin{aligned} N & ::= 0 \mid P \mid -P \\ P & ::= 1 \mid P0 \mid P1 \end{aligned}$$

- (i) Give a deterministic finite automaton that accepts the language generated by this context-free grammar. [4 marks]
- (ii) Give a regular expression that determines the same language. [1 mark]
- (iii) What is meant by *regular* context-free grammars and what is their connection with regular languages? Is the context-free grammar given above regular? [5 marks]

10 Structured Hardware Design

A design is required for a battery-operated device that replays stored music through headphones.

- (a) What are the properties of EAROM memories (also known as Flash)?
[4 marks]
- (b) Given that CD quality music is sampled at 44 ksps with 16 bits per stereo channel, and that MP3 compression will be used at a ratio of about 5 to 1, and that three hours storage capacity is required, how much EAROM memory is needed?
[4 marks]
- (c) Ignoring partition of function between silicon chips, sketch a block diagram for a basic design, including any connections, controls and features that are likely to be needed.
[8 marks]
- (d) How many custom chips should be developed for this product and what other custom toolings should be used for a profitable run of 250K production units?
[4 marks]

END OF PAPER