

Mobile and Sensor Systems

Lecture 3: Wireless Sensor Systems

Prof Cecilia Mascolo

In this lecture

- We will describe wireless sensor networks in general and the properties of sensor nodes.
- We will introduce sensor network MAC Layer issues and some solutions.

Wireless Sensor Networks?

- In many situations, we want to measure things to develop a better understanding of various phenomena.
- With this insight, we can then design novel or improved systems.

Example: Sensor Network Macroscopic



Conventional Manual Monitoring



Long-lived High-density Sensing Networks

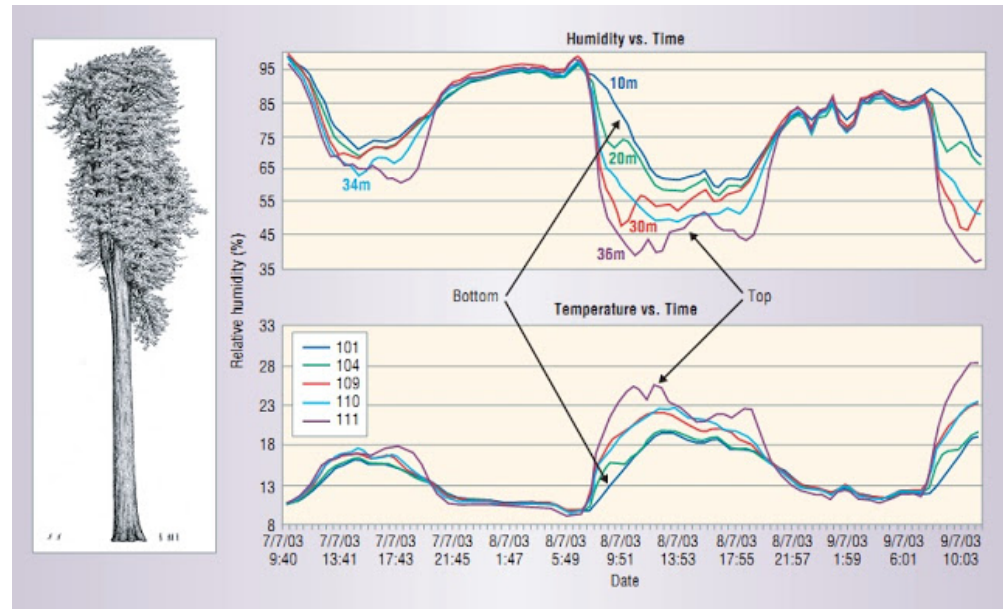

Many Applications

- Structural health monitoring
- Environmental monitoring
- Animal behaviour
- Warehouse logistics



Characteristics

- Farmer wants to cover his entire vineyard
 - Large number of sensing devices.
- He wants to keep the cost down
 - Low cost, resource constrained.
- He cannot run wires to these many devices
 - Battery powered, wireless.

An Example of Sensor Network Architecture

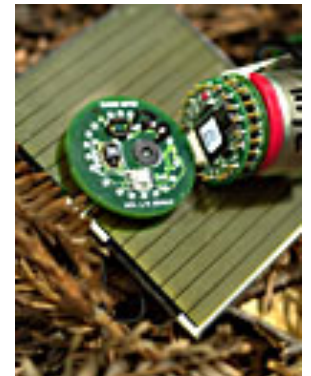
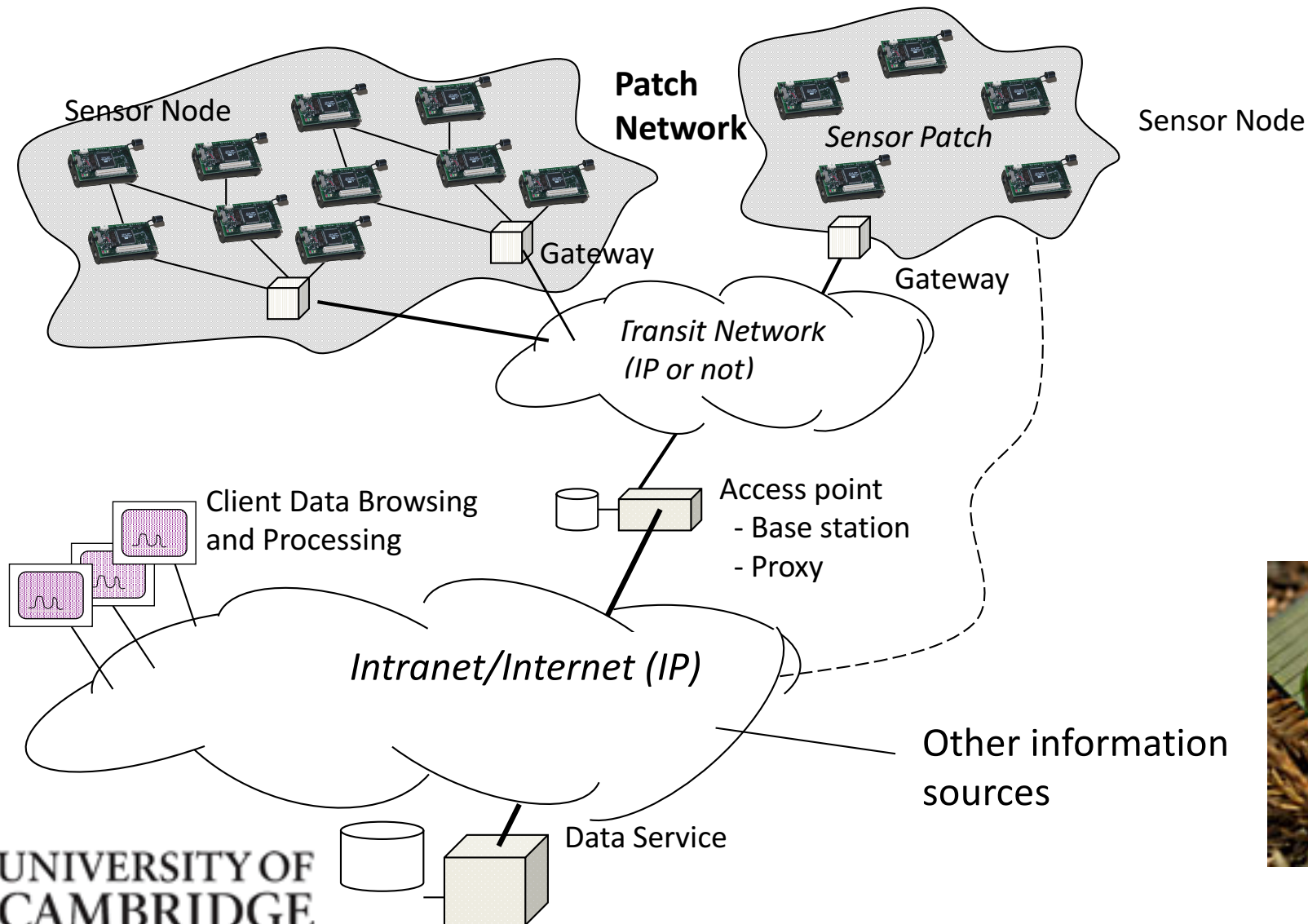

Sensor Systems vs Standard or Mobile Systems

- Sensor nodes have limited computational resources and energy.
- Sensor nodes are prone to failures (especially because they are often deployed in challenging conditions).
- The topology of a sensor network might not change frequently:
 - Many deployments involve nodes with fixed locations.
 - Some deployments may have mobile sensors.

Sensor Node

- A typical sensor node is composed of,
 - Sensing device
 - Low power radio
 - Small storage

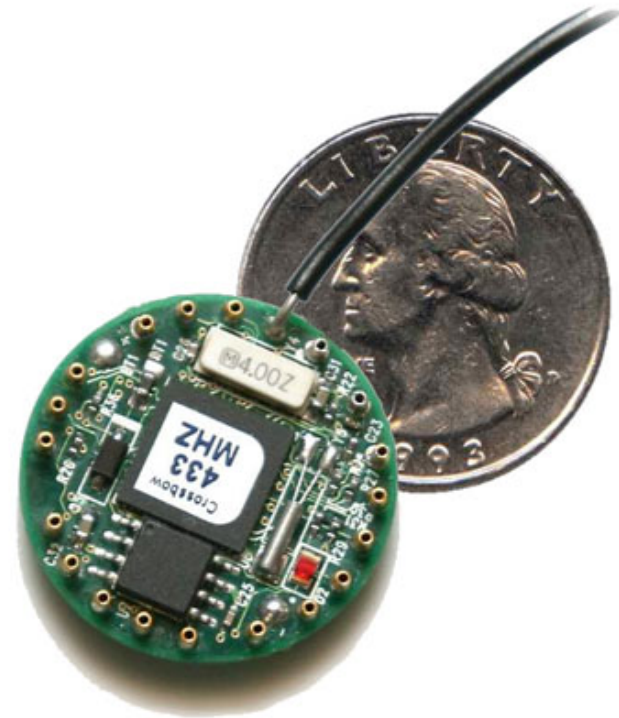

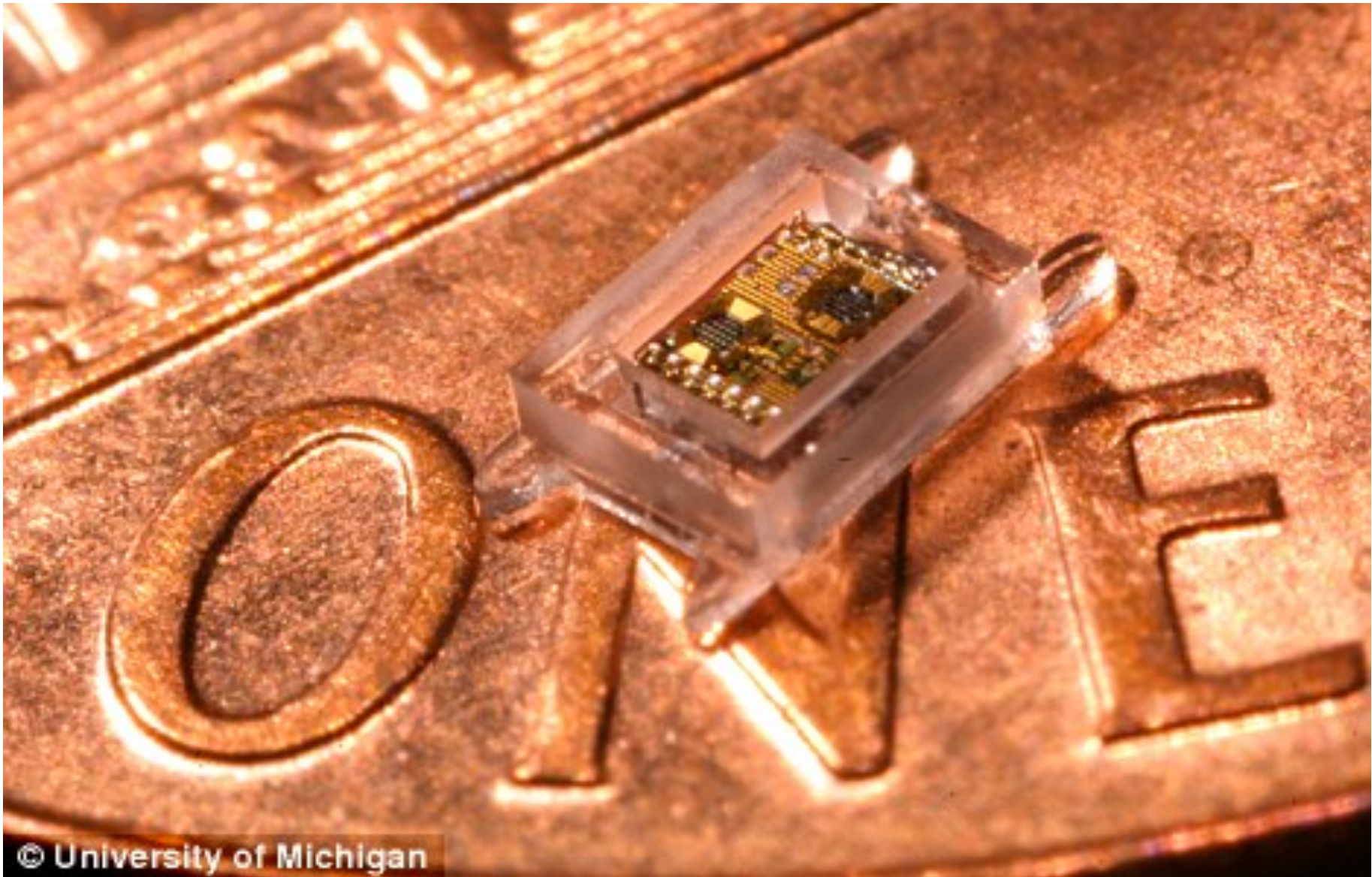

Michigan Micro Mote

What Operating System runs on a sensor?

- Operating system useful to simplify programming tasks and to allow more control over operations of the system
- But what can we do with such a constrained device?
- Given the kind of applications needed it is important to support concurrency...[frequent and parallel collection from different sensors]

Energy Management

- Local computation does not consume significant amount of energy.
- **The main source of energy consumption is the radio.**
- Current draw on Telosb,
 - Microcontroller ON, Radio OFF 1.8mA
 - Microcontroller ON, Radio ON 21mA

Energy Management

- In order to save energy, limit the number of radio transmissions.
- Idle listening consumes as much power as transmission.
- Current draw on Telosb,
 - Idle listening 23mA
 - Transmitting 21mA
- Idle listening is wasteful when average data rate is low.
- Switch off the radio when idle.
- Transmissions from other sensor nodes are lost.

Radio Duty Cycling

- Switch off the radio of all sensors at specific intervals:
 - Very precise synchronization.
 - Still probable idle time for sensors which do not communicate.
- More refined strategy:
 - Wave of switch off time depending on topology.
 - Still an overestimate of the communication needs of some sensors (traffic might be varying across the network).

Dynamic duty cycling

- More refined strategies have been proposed which aim to allow sensors with more packets to stay awake longer and others to sleep more.
 - Synchronized (e.g. S-MAC)
 - Asynchronous (e.g. B-MAC, X-MAC)
- Synchronized protocols try to **negotiate a schedule** among neighboring nodes.
- Asynchronous protocols rely on **preamble sampling** to connect a transmitter to receivers.

Sensor-MAC (S-MAC)

- Idea: Switch nodes off, ensure that neighboring nodes turn on simultaneously to allow packet exchange (rendez-vous)
 - Packet exchange occurs only in these **active periods**
 - Need to also exchange wakeup schedule between neighbors
 - When awake, essentially perform RTS/CTS
 - Use SYNCH, RTS, CTS phases

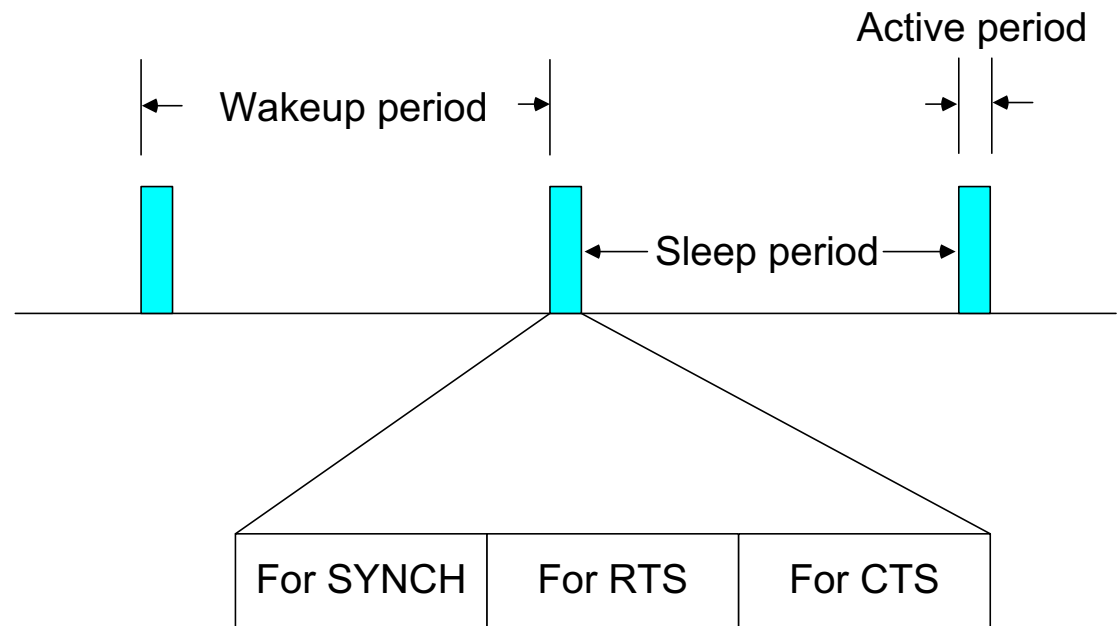

S-MAC

- SYNC phase divided into time slots with CSMA and backoffs to send schedule to neighbours.
- Y chooses a slot and if no signal is received in this slot, it will transmit its schedule to X otherwise it will wait for next wake up of X.
- RTS phase: X listens for RTS packets (CSMA contention).
- CTS phase: X sends one and extends its wake up time.

S-MAC synchronized islands

- Nodes try to pick up schedule synchronization from neighboring nodes.
- If no neighbor found, nodes pick some schedule to start with.
- If additional nodes join, some node might learn about two different schedules from different nodes
 - “Synchronized islands”.
- To bridge this gap, it has to follow both schemes and use more energy.

Preamble Sampling

- So far: Periodic sleeping supported by some means to synchronize wake up of nodes to ensure rendez-vous between sender and receiver.
- Alternative option: Don't try to explicitly synchronize nodes:
 - Have receiver sleep and only periodically sample the channel.
- Use **long preambles** to ensure that receiver stays awake to catch actual packet. Example: B-MAC and WiseMAC.

Start transmission:

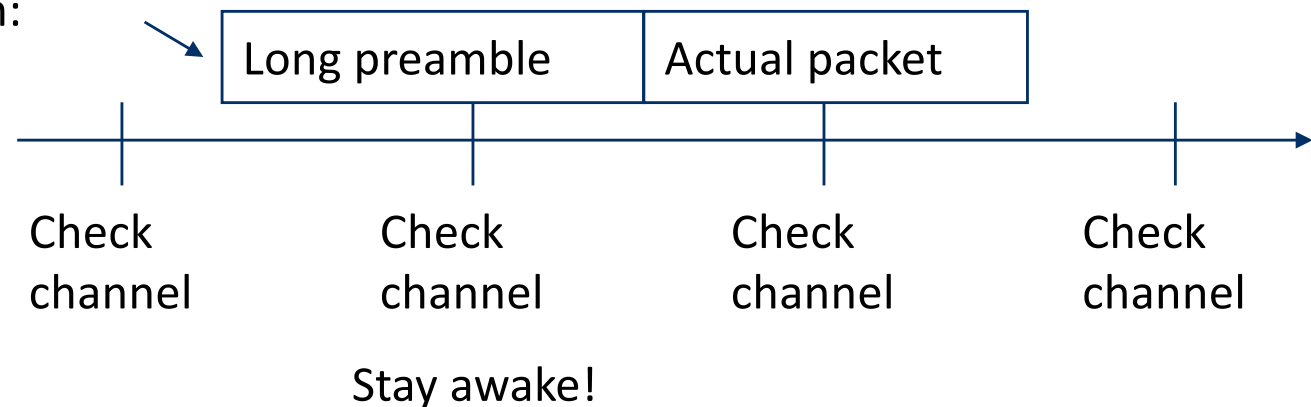

Problems with this technique

- Overhearing
 - All receivers listening to the preamble have to stay awake to find out who is the intended receiver.
- Energy Consumption
 - Long preamble causes increased energy consumption at both the transmitter and the receiver.
- Latency
 - Long preamble introduces per-hop latency.

X-MAC

- Short preamble
 - Reduce latency and reduce energy consumption
- Target in preamble
 - Minimize overhearing problem.
- Adding wait time between preambles
 - Reduces latency for the case where destination is awake before preamble completes.

X-MAC

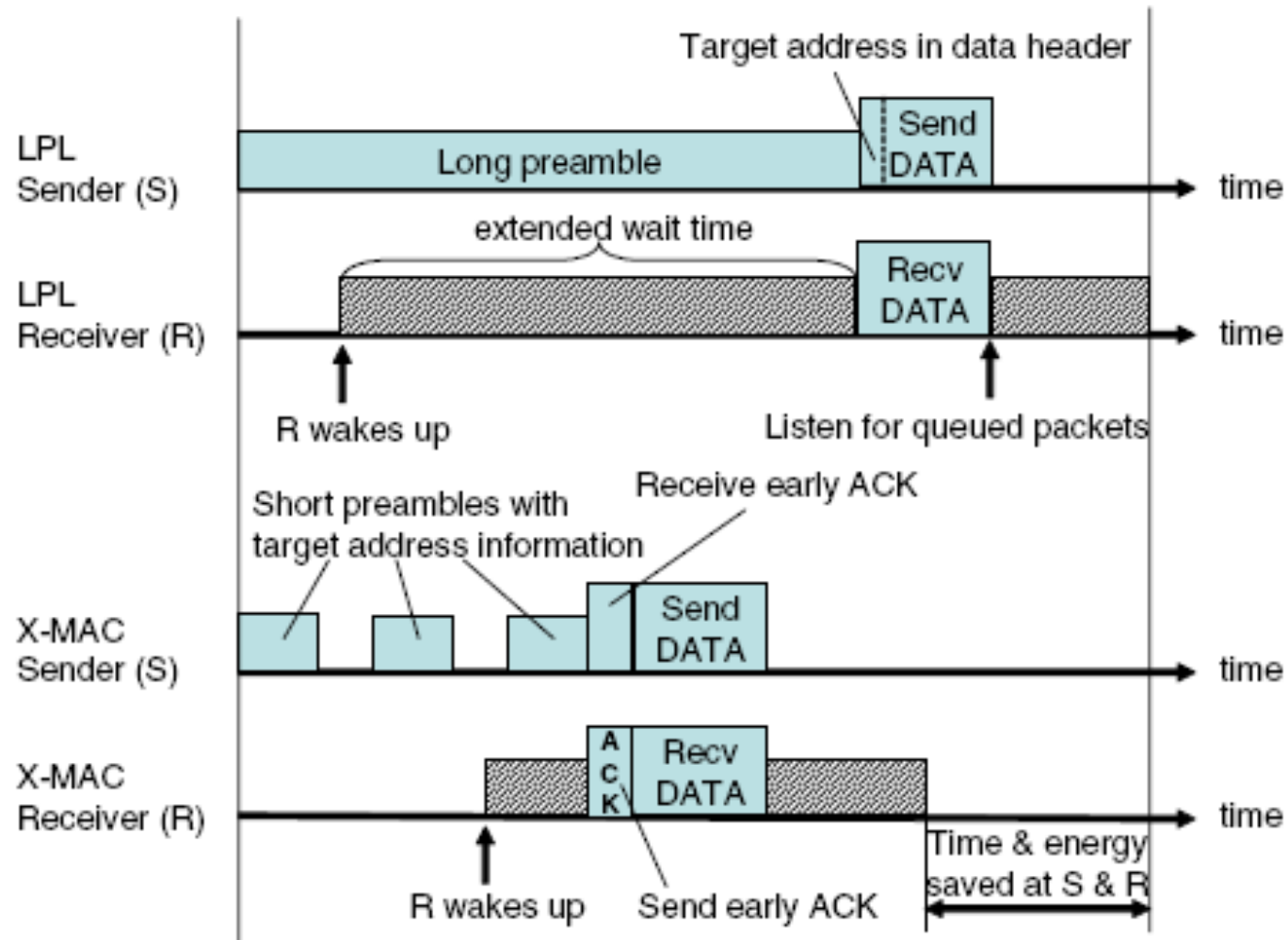

Low-Energy Adaptive Clustering Hierarchy (LEACH)

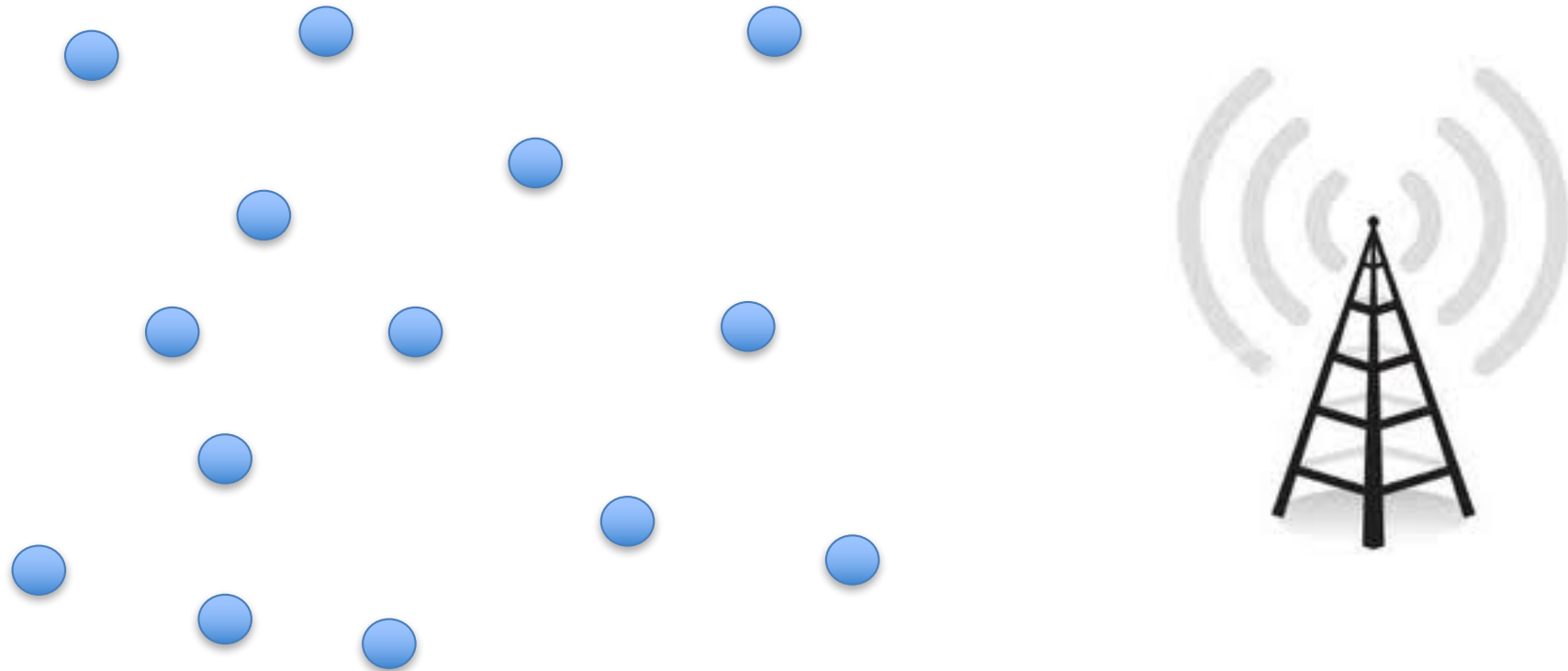

Low-Energy Adaptive Clustering Hierarchy (LEACH)

- Assumption: dense network of nodes, reporting to a central sink, each node can reach sink **directly**.
- Idea: Group nodes into “**clusters**”, controlled by **clusterhead**:
 - Setup phase; details: later.
 - About 5% of nodes become clusterhead (depends on scenario).
 - Role of clusterhead is rotated to share the burden.
 - Clusterheads advertise themselves, ordinary nodes join CH with strongest signal.
 - Clusterheads organize: CDMA code for all member transmission. TDMA schedule to be used within a cluster
- In steady state operation:
 - CHs collect & aggregate data from all cluster members.
 - Report aggregated data to sink using CSMA.

Low-Energy Adaptive Clustering Hierarchy (LEACH)

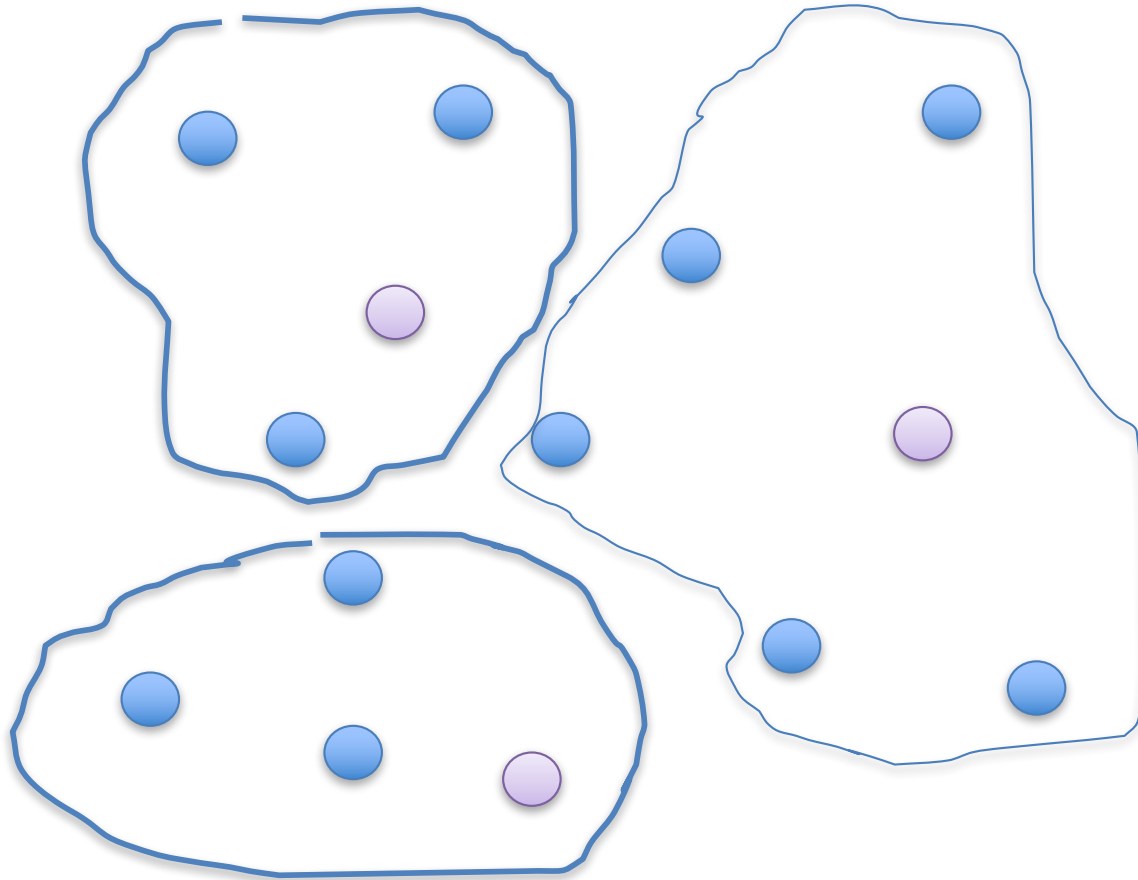

LEACH rounds

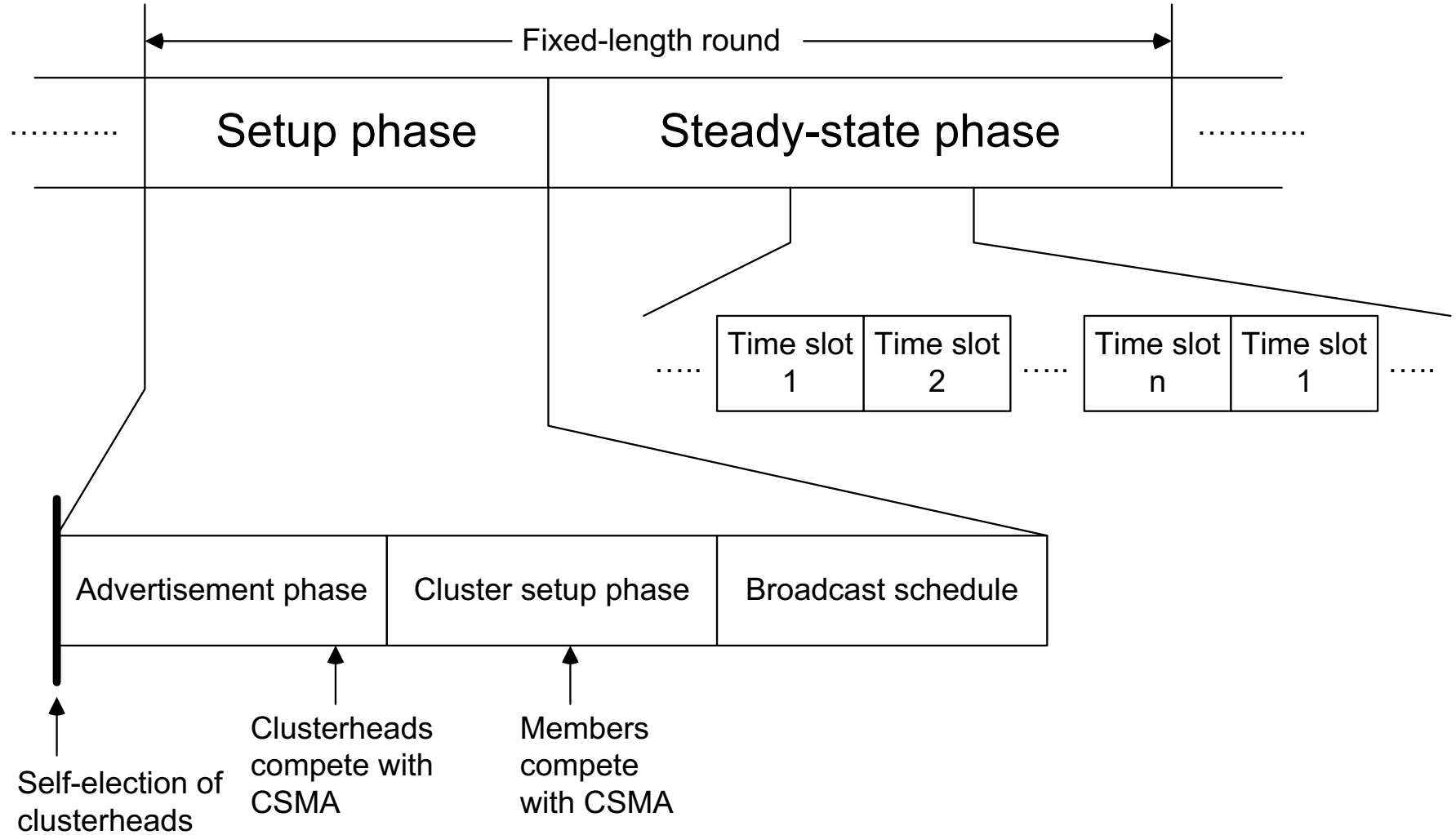

Summary

- We have described the characteristics of sensor systems and their challenges
- We have introduced MAC protocols for sensor systems

References

- TinyOS tutorial: <http://www.tinyos.net/tinyos-1.x/doc/tutorial/>
- SMAC: Ye, W., Heidemann, J., and Estrin, D. 2004. Medium access control with coordinated adaptive sleeping for wireless sensor networks. *IEEE/ACM Trans. Netw.* 12, 3 (Jun. 2004), 493-506.
- WISEMAC: El-Hoiydi, A. and Decotignie, J. 2004. WiseMAC: an ultra low power MAC protocol for the downlink of infrastructure wireless sensor networks. In *Proceedings of the Ninth international Symposium on Computers and Communications 2004 Volume 2 (Iscc'04) - Volume 02 (June 28 - July 01, 2004)*. ISCC. IEEE Computer Society, Washington, DC, 244-251.
- X-MAC: M. Buettner, G.V. Yee, E. Anderson, and R. Han, "X-MAC: a short preamble MAC protocol for duty-cycled wireless sensor networks," in *Proceedings of the 4th international conference on Embedded networked sensor systems* Boulder, Colorado, USA: ACM, 2006.
- LEACH: Energy-Efficient Communication Protocols for Wireless Microsensor Networks. Wendi Heinzelman, Anantha Chandrakasan, and Hari Balakrishnan,, *Proc. Hawaain Int'l Conf. on Systems Science*, January 2000.

