

Topic 6 – Applications

- Overview
- Traditional Applications (web)
- Infrastructure Services (DNS)
- Multimedia Applications (SIP)
- P2P Networks

Client-server architecture

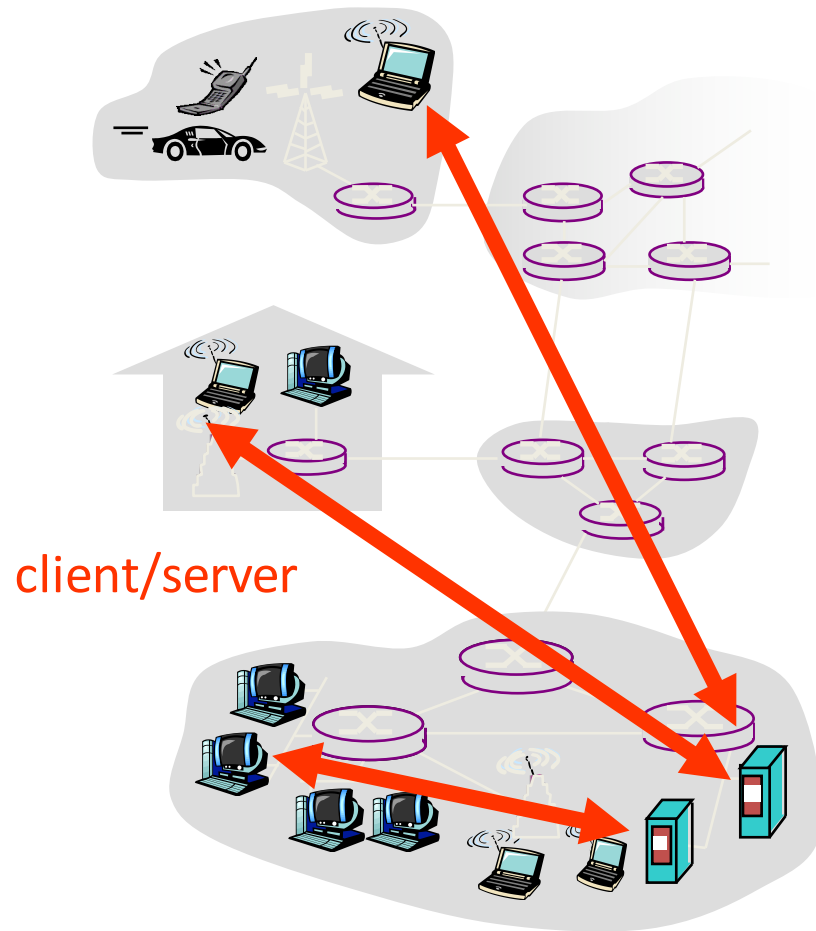

server:

- always-on host
- permanent IP address
- server farms for scaling

clients:

- communicate with server
- may be intermittently connected
- may have dynamic IP addresses
- do not communicate directly with each other

Pure P2P architecture

- *no* always-on server
- arbitrary end systems directly communicate
- peers are intermittently connected and change IP addresses

Highly scalable but difficult to manage

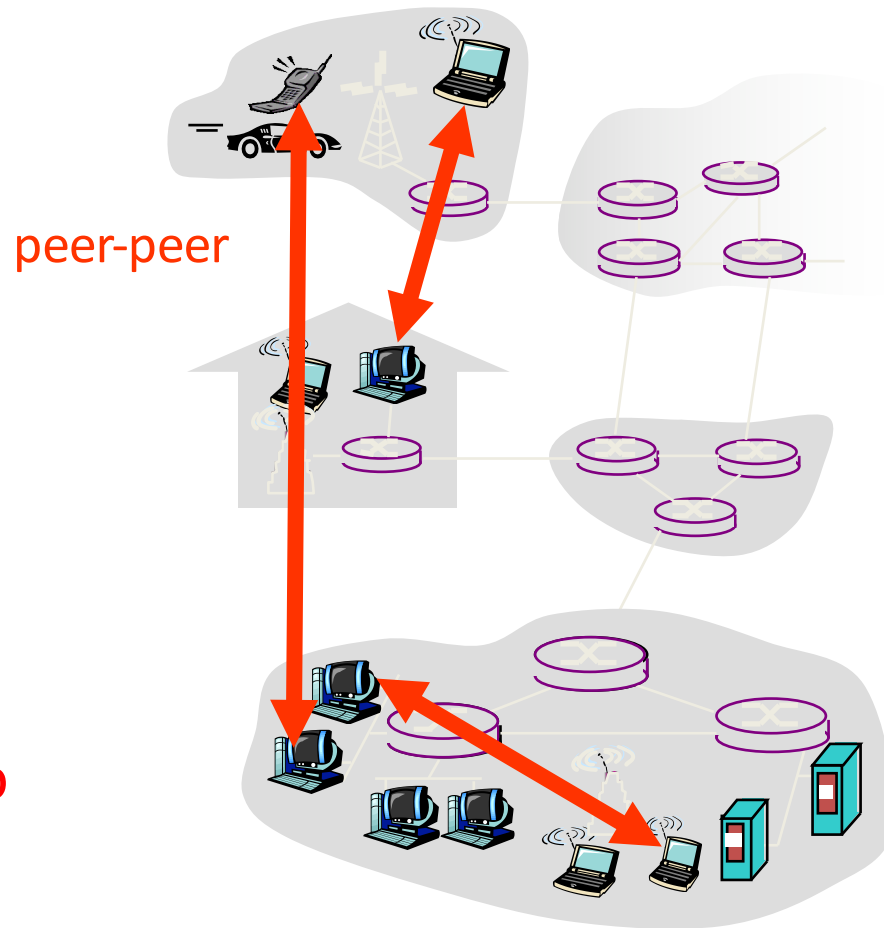

Hybrid of client-server and P2P

Skype

- voice-over-IP P2P application
- centralized server: finding address of remote party:
- client-client connection: direct (not through server)

Instant messaging

- chatting between two users is P2P
- centralized service: client presence detection/location
 - user registers its IP address with central server when it comes online
 - user contacts central server to find IP addresses of buddies

Addressing processes

- to receive messages, process must have *identifier*
- host device has unique 32-bit IP address
- Q: does IP address of host on which process runs suffice for identifying the process?
 - A: No, *many* processes can be running on same host
- *identifier* includes both **IP address** and **port numbers** associated with process on host.
- Example port numbers:
 - HTTP server: 80
 - Mail server: 25
- to send HTTP message to yuba.stanford.edu web server:
 - **IP address:** 171.64.74.58
 - **Port number:** 80
- more shortly...

Recall: Multiplexing is a service provided by (each) layer too!

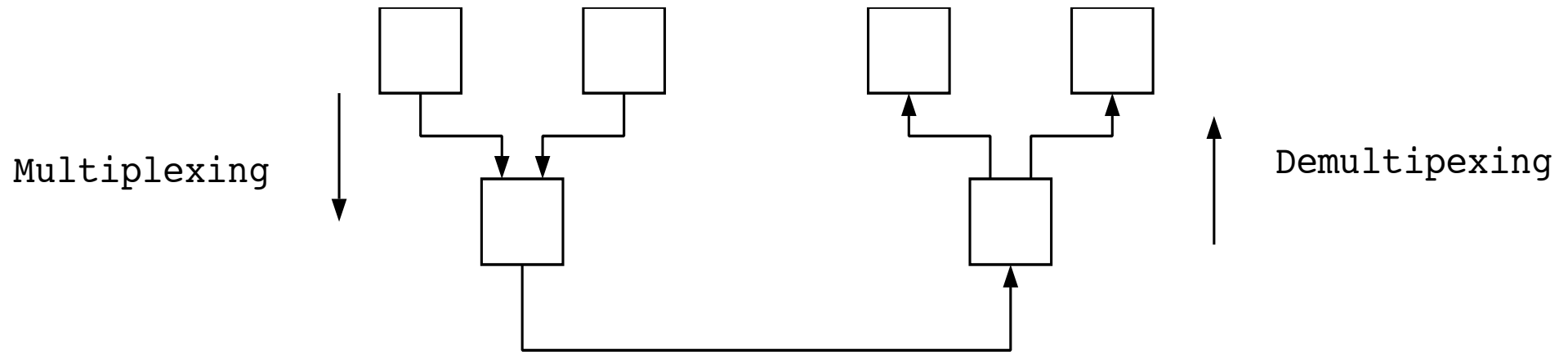

Application: one web-server multiple sets of content
Host: one machine multiple services
Network: one physical box multiple addresses (like vns.cl.cam.ac.uk)
....

UNIX: /etc/protocols = examples of different transport-protocols on top of IP

UNIX: /etc/services = examples of different (TCP/UDP) services – by port

(These files are an example of a (static)⁷)

App-layer protocol defines

- Types of messages exchanged,
 - e.g., request, response
- Message syntax:
 - what fields in messages & how fields are delineated
- Message semantics
 - meaning of information in fields
- Rules for when and how processes send & respond to messages

Public-domain protocols:

- defined in RFCs
- allows for interoperability
- e.g., HTTP, SMTP

Proprietary protocols:

- e.g., Skype

What transport service does an app need?

Data loss

- some apps (e.g., audio) can tolerate some loss
- other apps (e.g., file transfer, telnet) require 100% reliable data transfer

Timing

- some apps (e.g., Internet telephony, interactive games) require low delay to be “effective”

Throughput

- some apps (e.g., multimedia) require minimum amount of throughput to be “effective”
- other apps (“elastic apps”) make use of whatever throughput they get

Security

- Encryption, data integrity, ...

Mysterious secret of *Transport*

- There is more than sort of *transport* layer

Shocked?

I seriously doubt it...

Recall the two most common TCP and UDP

Naming

- Internet has one global system of addressing: IP
 - By explicit design
- And one global system of naming: DNS
 - Almost by accident
- At the time, only items worth naming were hosts
 - A mistake that causes many painful workarounds
- Everything is now named relative to a host
 - Content is most notable example (URL structure)

Logical Steps in Using Internet

- Human has name of entity she wants to access
 - Content, host, etc.
- Invokes an application to perform relevant task
 - Using that name
- App invokes DNS to translate name to address
- App invokes transport protocol to contact host
 - Using address as destination

Addresses vs Names

- Scope of relevance:
 - App/user is primarily concerned with names
 - Network is primarily concerned with addresses
- Timescales:
 - Name lookup once (or get from cache)
 - Address lookup on each packet
- When moving a host to a different subnet:
 - The address changes
 - The name does not change
- When moving content to a differently named host
 - Name and address both change!

Relationship Between Names&Addresses

- Addresses can **change** underneath
 - Move www.bbc.co.uk to 212.58.246.92
 - Humans/Apps should be unaffected
- Name could map to **multiple** IP addresses
 - www.bbc.co.uk to multiple replicas of the Web site
 - Enables
 - Load-balancing
 - Reducing latency by picking nearby servers
- **Multiple names** for the same address
 - E.g., aliases like www.bbc.co.uk and bbc.co.uk
 - Mnemonic stable name, and dynamic canonical name
 - Canonical name = actual name of host

Mapping from Names to Addresses

- Originally: per-host file /etc/hosts
 - SRI (Menlo Park) kept master copy
 - Downloaded regularly
 - Flat namespace
- Single server not resilient, doesn't scale
 - Adopted a distributed hierarchical system
- Two intertwined hierarchies:
 - Infrastructure: hierarchy of DNS servers
 - Naming structure: `www.bbc.co.uk`

Domain Name System (DNS)

- Top of hierarchy: Root
 - Location hardwired into other servers
- Next Level: Top-level domain (TLD) servers
 - .com, .edu, etc.
 - .uk, .au, .to, etc.
 - Managed professionally
- Bottom Level: Authoritative DNS servers
 - Actually do the mapping
 - Can be maintained locally or by a service provider

Distributed Hierarchical Database

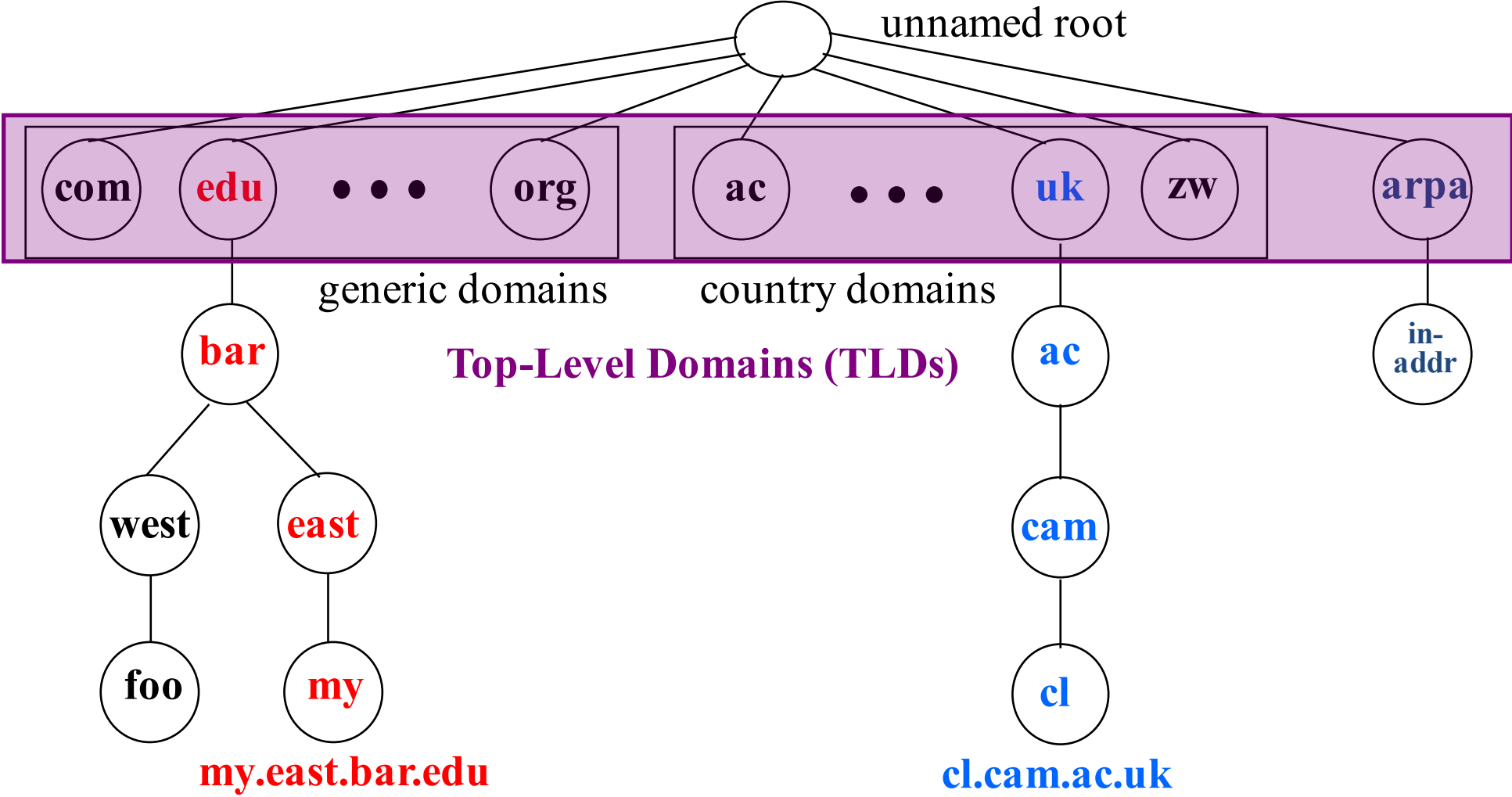

DNS Root

- Located in Virginia, USA
- How do we make the root scale?

Verisign, Dulles, VA

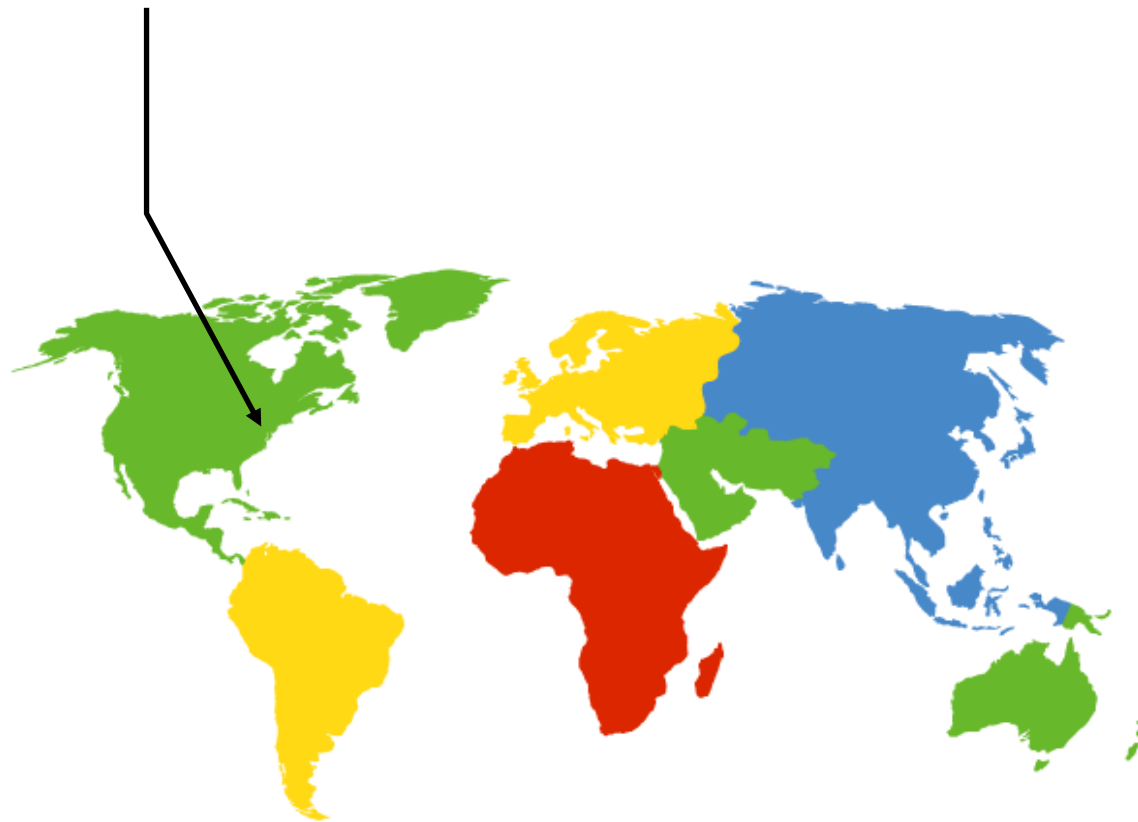

DNS Root Servers

- 13 root servers (see <http://www.root-servers.org/>)
 - Labeled A through M
- Does **this** scale?



DNS Root Servers

- 13 root servers (see <http://www.root-servers.org/>)
 - Labeled A through M
- Replication via **any-casting** (localized routing for addresses)



Using DNS

- Two components
 - Local DNS servers
 - Resolver software on hosts
- Local DNS server (“default name server”)
 - Usually near the endhosts that use it
 - Local hosts configured with local server (e.g., `/etc/resolv.conf`) or learn server via DHCP
- Client application
 - Extract server name (e.g., from the URL)
 - Do `gethostbyname()` to trigger resolver code

How Does Resolution Happen? (Iterative example)

Host at **cl.cam.ac.uk**
wants IP address for
www.stanford.edu

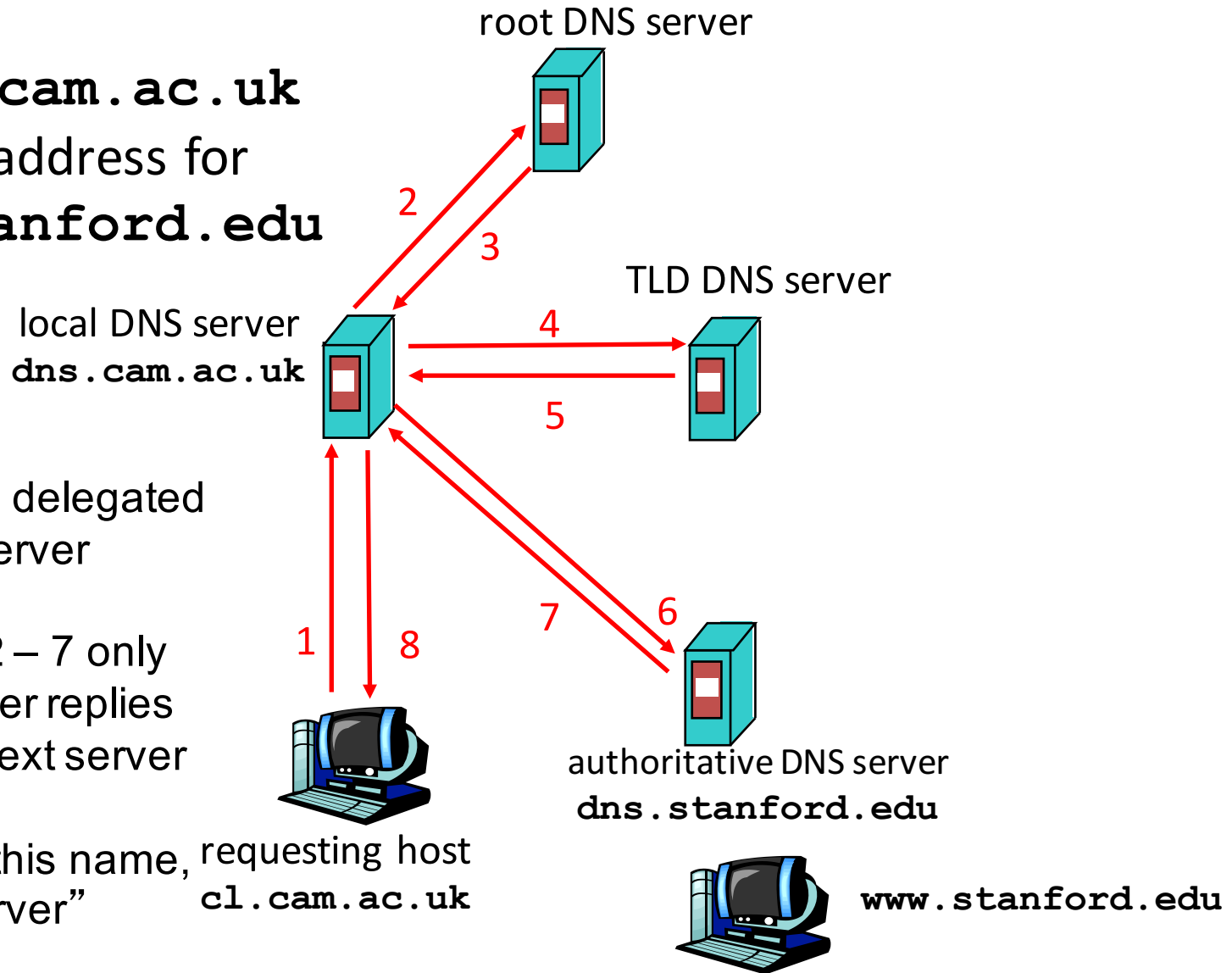

iterated query:

- Host enquiry is delegated to local DNS server
- Consider transactions 2 – 7 only
- contacted server replies with name of next server to contact
- “I don’t know this name, but ask this server”

DNS name resolution **recursive** example

recursive query:

- ❑ puts burden of name resolution on contacted name server
- ❑ heavy load?

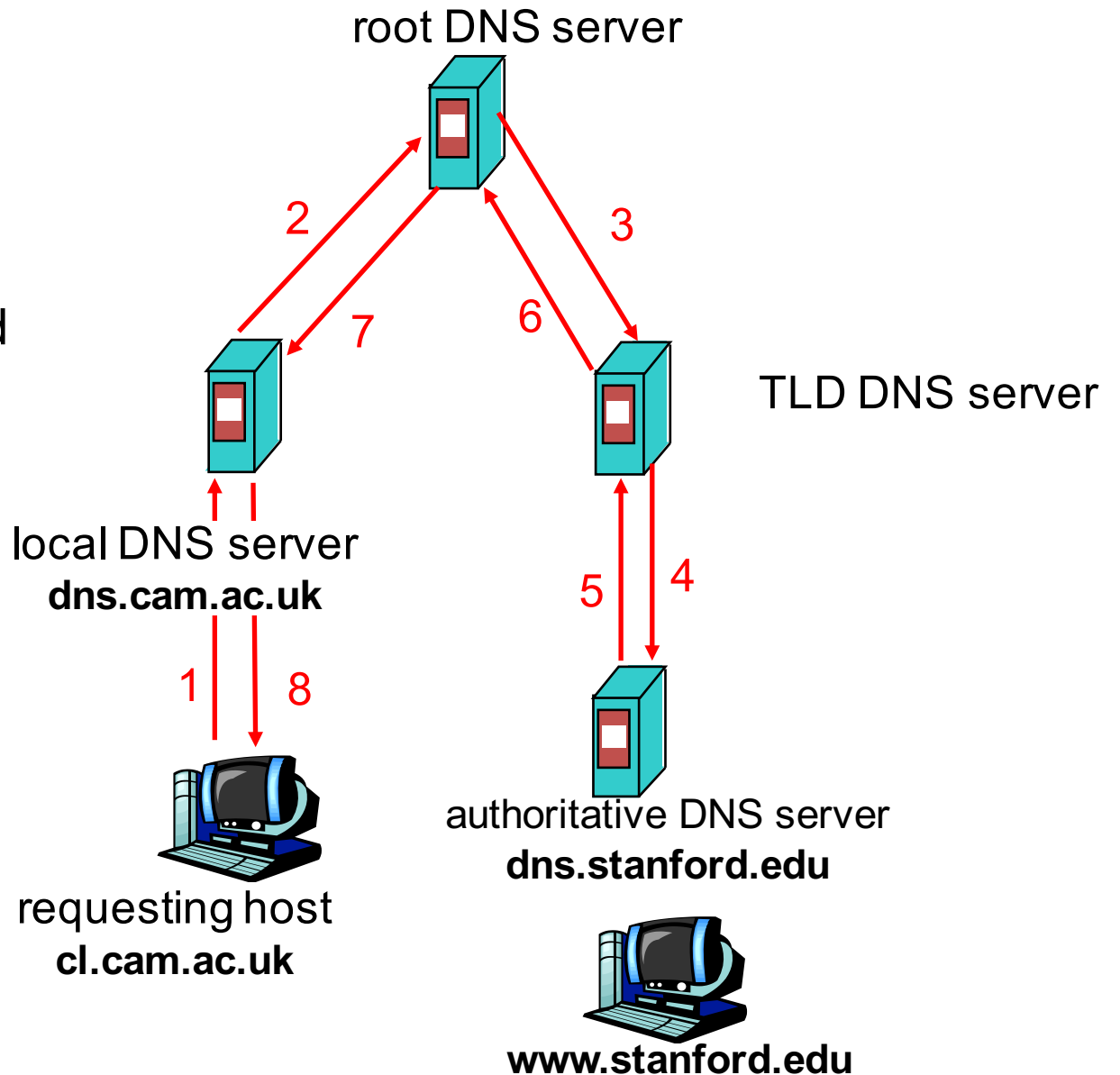

Recursive and Iterative Queries - Hybrid case

- **Recursive query**
 - Ask server to get answer for you
 - E.g., requests 1,2 and responses 9,10
- **Iterative query**
 - Ask server who to ask next
 - E.g., all other request-response pairs

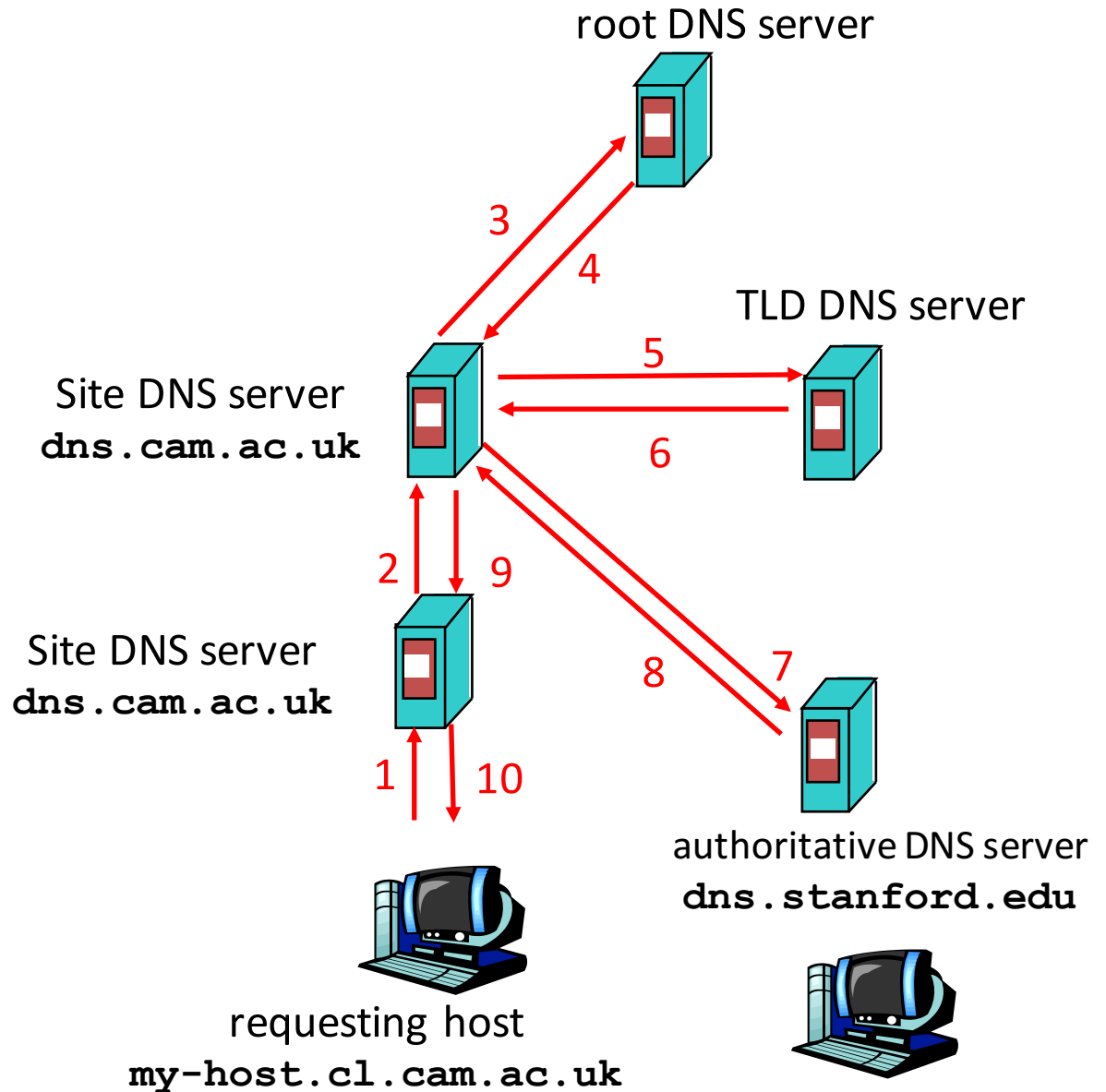

DNS Caching

- Performing all these queries takes time
 - And all this **before** actual communication takes place
 - E.g., 1-second latency before starting Web download
- **Caching** can greatly reduce overhead
 - The top-level servers very rarely change
 - Popular sites (e.g., www.bbc.co.uk) visited often
 - Local DNS server often has the information cached
- How DNS caching works
 - DNS servers cache responses to queries
 - Responses include a “**time to live**” (TTL) field
 - Server deletes cached entry after TTL expires

Negative Caching

- Remember things that don't work
 - Misspellings like *bbcc.co.uk* and *www.bbc.com.uk*
 - These can take a long time to fail the first time
 - Good to remember that they don't work
 - ... so the failure takes less time the next time around
- But: negative caching is **optional**
 - And not widely implemented

Reliability

- DNS servers are **replicated** (primary/secondary)
 - Name service available if at least one replica is up
 - Queries can be load-balanced between replicas
- Usually, UDP used for queries
 - Need reliability: must implement this on top of UDP
 - Spec supports TCP too, but not always implemented
- Try alternate servers on timeout
 - **Exponential backoff** when retrying same server
- Same identifier for all queries
 - Don't care which server responds

DNS Measurements (MIT data from 2000)

- What is being looked up?
 - ~60% requests for A records
 - ~25% for PTR records
 - ~5% for MX records
 - ~6% for ANY records
- How long does it take?
 - Median ~100msec (but 90th percentile ~500msec)
 - 80% have no referrals; 99.9% have fewer than four
- Query packets per lookup: ~2.4
 - But this is misleading....

DNS Measurements (MIT data from 2000)

- Does DNS give answers?
 - ~23% of lookups fail to elicit an answer!
 - ~13% of lookups result in NXDOMAIN (or similar)
 - Mostly reverse lookups
 - Only ~64% of queries are successful!
 - *How come the web seems to work so well?*
- ~ 63% of DNS packets in unanswered queries!
 - Failing queries are frequently retransmitted
 - 99.9% successful queries have ≤ 2 retransmissions

DNS Measurements (MIT data from 2000)

- Top 10% of names accounted for ~70% of lookups
 - Caching should really help!
- 9% of lookups are unique
 - Cache hit rate can never exceed 91%
- Cache hit rates ~ 75%
 - But caching for more than 10 hosts doesn't add much

A Common Pattern.....

- Distributions of various metrics (file lengths, access patterns, etc.) often have two properties:
 - Large fraction of total metric in the top 10%
 - Sizable fraction (~10%) of total fraction in low values
- Not an exponential distribution
 - Large fraction is in top 10%
 - But low values have very little of overall total
- Lesson: have to pay attention to both ends of dist.
- Here: caching helps, but not a panacea

Moral of the Story

- If you design a highly resilient system, many things can be going wrong without you noticing it!

and this is a **good** thing

Cache Poisoning, an **old badness** example

- Suppose you are a Bad Guy and you control the name server for foobar.com. You receive a request to resolve www.foobar.com and reply:

```
;; QUESTION SECTION:
;www.foobar.com.      IN      A

;; ANSWER SECTION:
www.foobar.com.      300    IN      A      212.44.9.144

;; AUTHORITY SECTION:
foobar.com.          600    IN      NS      dns1.foobar.com.
foobar.com.          600    IN      NS      google.com.

;; ADDITIONAL SECTION:
google.com.          5      IN      A      212.44.9.155
```

Evidence of the attack disappears 5 seconds later!



A foobar.com machine, *not* google.com

DNS and Security

- No way to verify answers
 - Opens up DNS to many potential attacks
 - DNSSEC fixes this
- Most obvious vulnerability: recursive resolution
 - Using recursive resolution, host must trust DNS server
 - When at Starbucks, server is under their control
 - And can return whatever values it wants
- More subtle attack: Cache poisoning
 - Those “additional” records can be anything!

Why is the web so successful?

- What do the web, youtube, facebook, tumblr, twitter, flickr, have in common?
 - The ability to self-publish
- Self-publishing that is easy, independent, *free*
- No interest in collaborative and idealistic endeavor
 - People aren't looking for Nirvana (or even Xanadu)
 - People also aren't looking for technical perfection
- Want to make their mark, and find something neat
 - Two sides of the same coin, creates synergy
 - “Performance” more important than dialogue....

Web Components

- Infrastructure:
 - Clients
 - Servers
 - Proxies
- Content:
 - Individual objects (files, etc.)
 - Web sites (coherent collection of objects)
- Implementation
 - HTML: formatting content
 - URL: naming content
 - HTTP: protocol for exchanging content
 - Any content not just HTML!

HTML: HyperText Markup Language

- *A Web page* has:
 - Base HTML file
 - Referenced objects (*e.g.*, images)
- HTML has several functions:
 - Format text
 - Reference images
 - Embed *hyperlinks* (HREF)

URL Syntax

***protocol** : //hostname[:port]/directorypath/resource*

protocol http, ftp, https, smtp, rtsp, etc.

hostname DNS name, IP address

port Defaults to protocol's standard port
e.g. http: 80 https: 443

directory path Hierarchical, reflecting file system

resource Identifies the desired resource

Can also extend to program executions:

```
http://us.f413.mail.yahoo.com/ym/ShowLetter?box=%40B%40Bulk&MsgId=2604_1744106_29699_1123_1261_0_28917_3552_1289957100&Search=&Nhead=f&YY=31454&order=down&sort=date&pos=0&view=a&head=b
```

HyperText Transfer Protocol (HTTP)

- Request-response protocol
- Reliance on a global namespace
- Resource *metadata*
- *Stateless*
- ASCII format

```
$ telnet www.cl.cam.ac.uk 80  
GET /~awm22/win HTTP/1.0  
<blank line, i.e., CRLF>
```

Steps in HTTP Request

- HTTP Client initiates TCP connection to server
 - SYN
 - SYNACK
 - ACK
- Client sends HTTP request to server
 - Can be piggybacked on TCP's ACK
- HTTP Server responds to request
- Client receives the request, terminates connection
- TCP connection termination exchange

How many RTTs for a single request?

Client-Server Communication

- two types of HTTP messages: *request, response*
- HTTP request message: (GET POST HEAD)

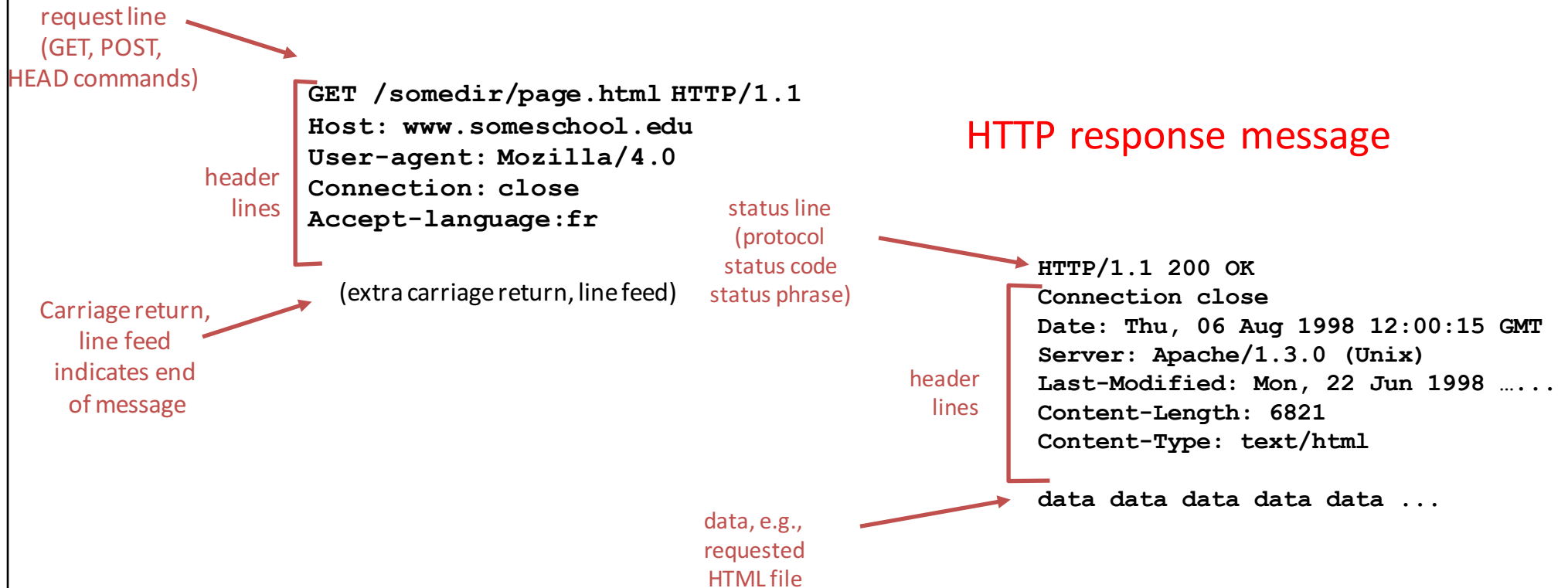

Different Forms of Server Response

- Return a file
 - URL matches a file (*e.g.*, `/www/index.html`)
 - Server returns file as the response
 - Server generates appropriate response header
- Generate response dynamically
 - URL triggers a program on the server
 - Server runs program and sends output to client
- Return meta-data with no body

HTTP Resource Meta-Data

- Meta-data
 - Info *about* a resource, stored as a separate entity
- Examples:
 - Size of resource, last modification time, type of content
- Usage example: Conditional GET Request
 - Client requests object **"If-modified-since"**
 - If unchanged, **"HTTP/1.1 304 Not Modified"**
 - No body in the server's response, only a header

HTTP is *Stateless*

- Each request-response treated independently
 - Servers *not* required to retain state
- **Good:** Improves scalability on the server-side
 - Failure handling is easier
 - Can handle higher rate of requests
 - Order of requests doesn't matter
- **Bad:** Some applications **need** persistent state
 - Need to uniquely identify user or store temporary info
 - *e.g.*, Shopping cart, user profiles, usage tracking, ...

State in a Stateless Protocol:

Cookies

- *Client-side* state maintenance
 - Client stores small^(?) state on behalf of server
 - Client sends state in future requests to the server
- Can provide authentication

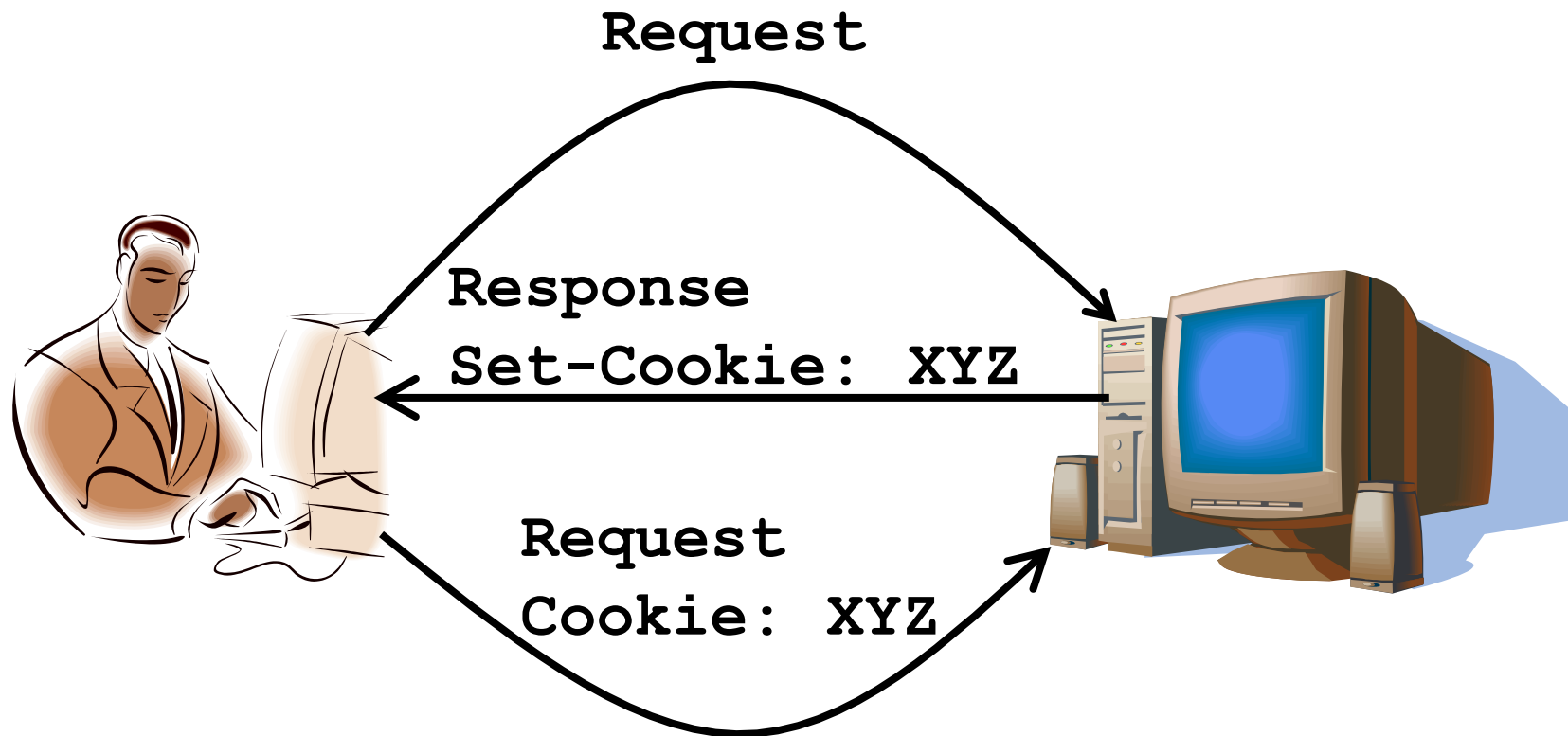

HTTP Performance

- Most Web pages have multiple objects
 - *e.g.*, HTML file and a bunch of embedded images
- How do you retrieve those objects (naively)?
 - *One item at a time*
- Put stuff in the optimal place?
 - *Where is that precisely?*
 - ***Enter the Web cache and the CDN***

Fetch HTTP Items: Stop & Wait

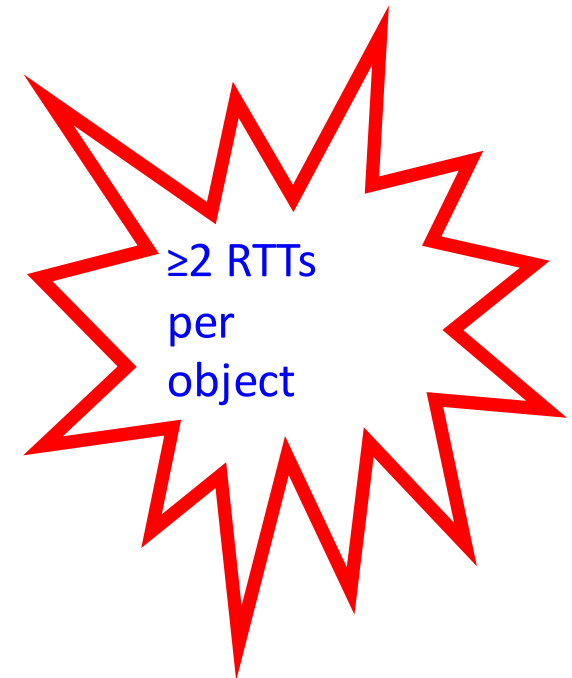
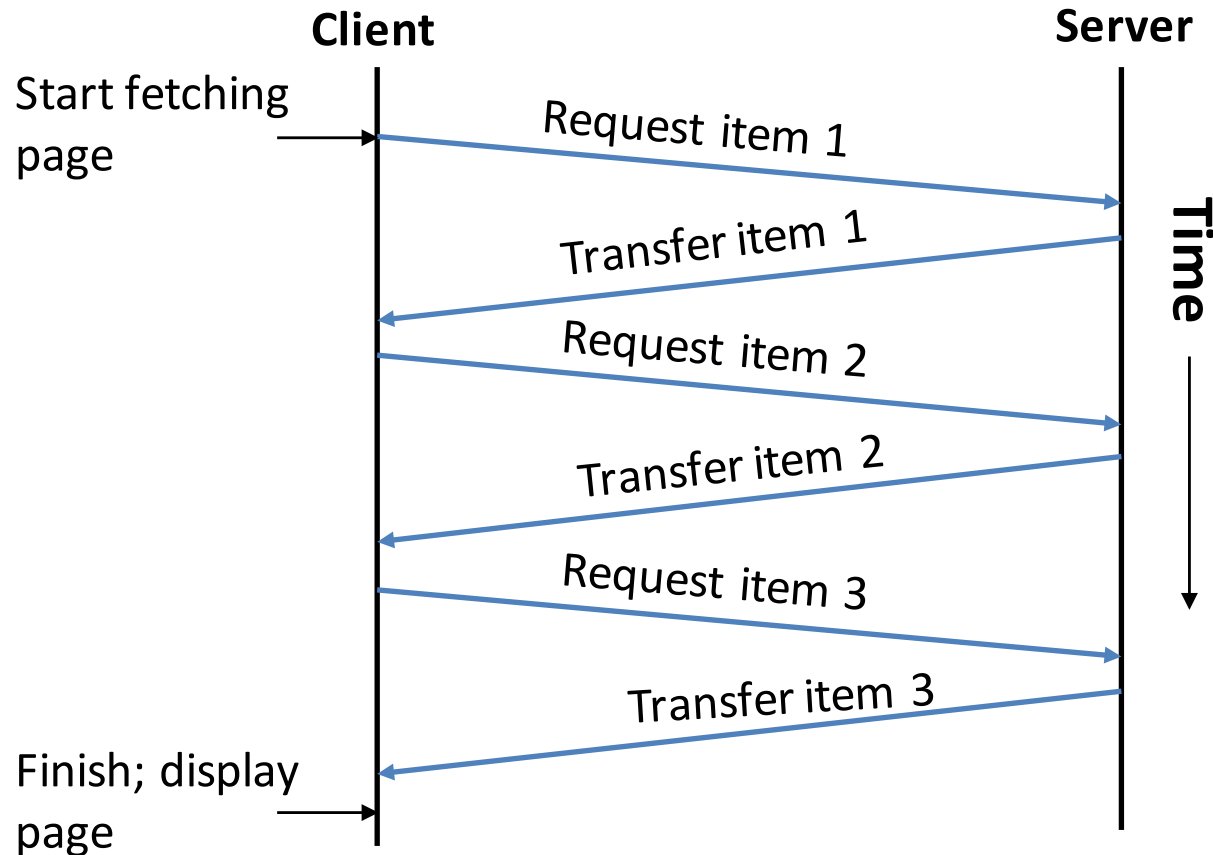

Improving HTTP Performance: Concurrent Requests & Responses

- Use multiple connections *in parallel*
- Does not necessarily maintain order of responses

- Client = 😊
- Server = 😊
- Network = ☹️ Why?

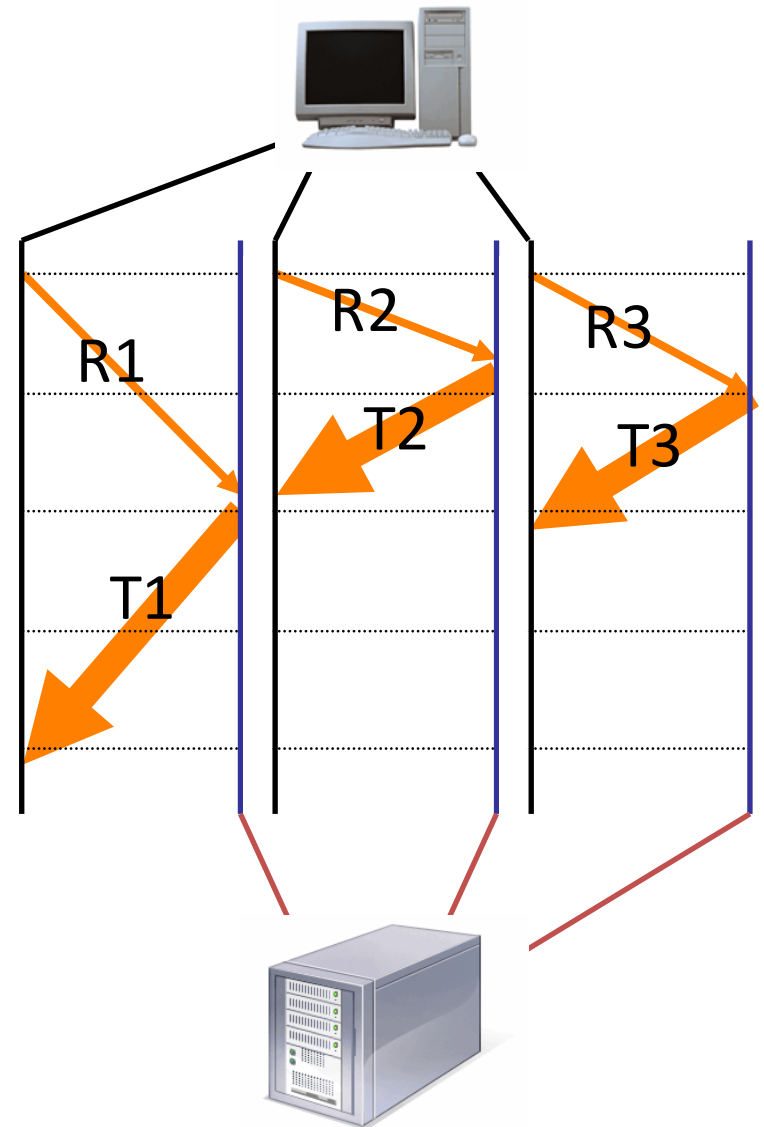

Improving HTTP Performance: Pipelined Requests & Responses

- *Batch* requests and responses
 - Reduce connection overhead
 - Multiple requests sent in a single batch
 - Maintains order of responses
 - Item 1 always arrives before item 2
- How is this different from concurrent requests/responses?
 - Single TCP connection

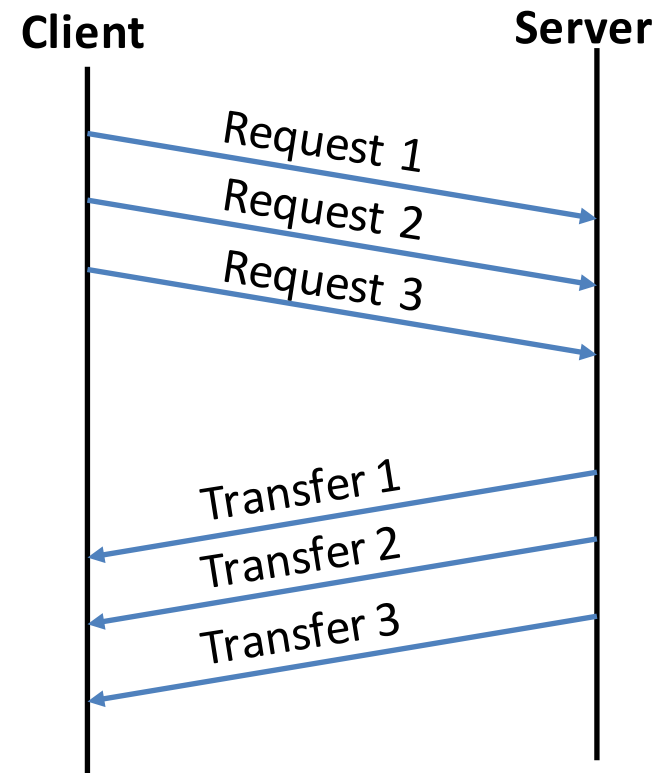

Improving HTTP Performance:
Persistent Connections

- Enables multiple transfers per connection
 - Maintain TCP connection across multiple requests
 - Including transfers subsequent to current page
 - Client or server can tear down connection
- Performance advantages:
 - Avoid overhead of connection set-up and tear-down
 - Allow TCP to learn more accurate RTT estimate
 - Allow TCP congestion window to increase
 - i.e., leverage previously discovered bandwidth
- Default in HTTP/1.1

HTTP *evolution*

- 1.0 – one object per TCP: simple but **slow**
- Parallel connections - multiple TCP, one object each: **wastes b/w, may be svr limited, out of order**
- 1.1 pipelining – aggregate retrieval time: ordered, multiple objects sharing single TCP
- 1.1 persistent – aggregate TCP overhead: lower overhead in time, increase overhead at ends (**e.g., when should/do you close the connection?**)

Scorecard: Getting n Small Objects

Time dominated by latency

- One-at-a-time: $\sim 2n$ RTT
- Persistent: $\sim (n+1)$ RTT
- M concurrent: $\sim 2[n/m]$ RTT
- Pipelined: ~ 2 RTT
- Pipelined/Persistent: ~ 2 RTT first time, RTT later

Scorecard: Getting n Large Objects

Time dominated by bandwidth

- One-at-a-time: $\sim nF/B$
- M concurrent: $\sim [n/m] F/B$
 - assuming shared with large population of users
- Pipelined and/or persistent: $\sim nF/B$
 - The only thing that helps is getting more bandwidth..

Improving HTTP Performance: Caching

- Many clients transfer **same information**
 - Generates **redundant** server and network load
 - Clients experience **unnecessary** latency

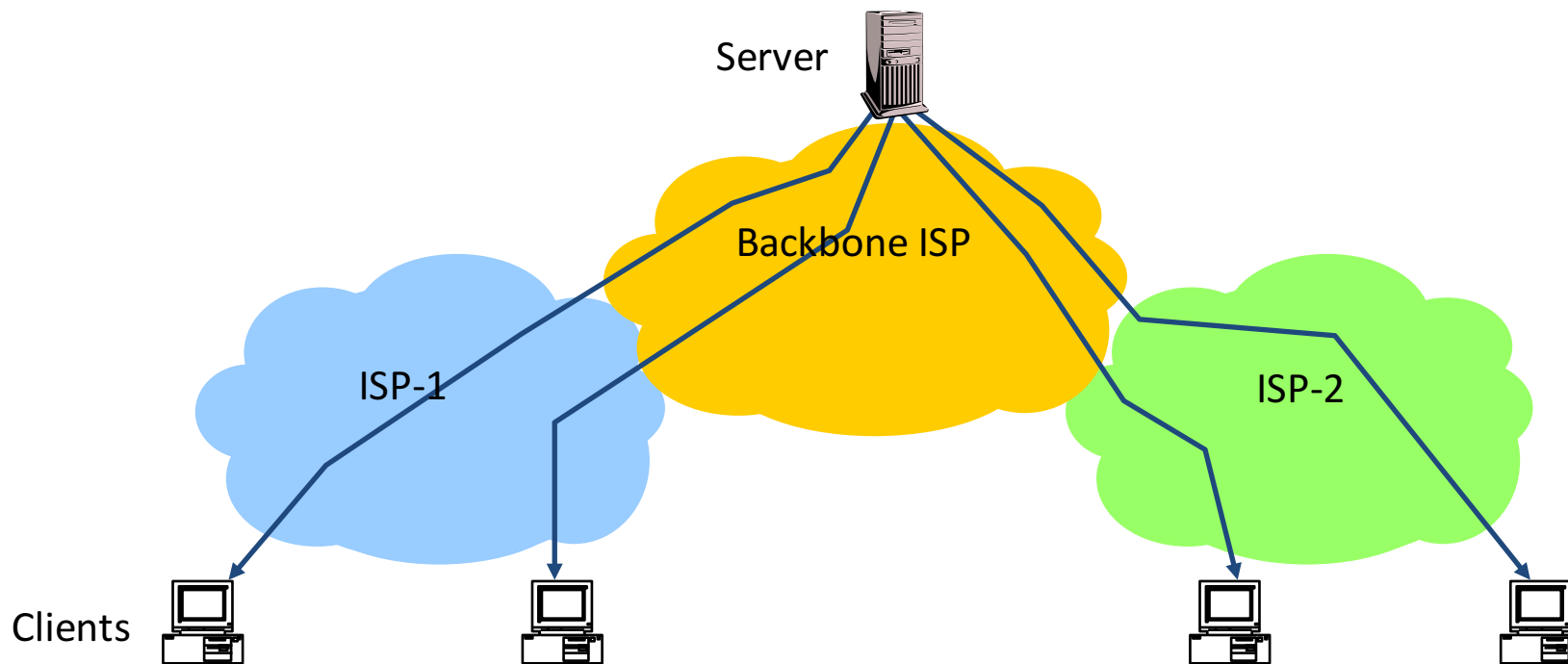

Improving HTTP Performance:
Caching: How

- Modifier to GET requests:
 - `If-modified-since` – returns “not modified” if resource not modified since specified time
- Response header:
 - `Expires` – how long it’s safe to cache the resource
 - `No-cache` – ignore all caches; always get resource directly from server

Caching: Why

- Motive for placing content closer to client:
 - User gets better response time
 - Content providers get happier users
 - Time is money, really!
 - Network gets reduced load
- Why does caching work?
 - Exploits *locality of reference*
- How well does caching work?
 - Very well, up to a limit
 - Large overlap in content
 - But many unique requests

Improving HTTP Performance: Caching on the Client

Example: Conditional GET Request

- Return resource only if it has changed at the server

– Save server resources!
Request from client to server:

```
GET /~awm22/win HTTP/1.1  
Host: www.cl.cam.ac.uk  
User-Agent: Mozilla/4.03  
If-Modified-Since: Sun, 27 Aug 2006 22:25:50 GMT  
<CRLF>
```

- HOW?
 - Client specifies “if-modified-since” time in request
 - Server compares this against “last modified” time of desired resource
 - Server returns “304 Not Modified” if resource has not changed
 - ... or a “200 OK” with the latest version otherwise

Improving HTTP Performance: Caching with Reverse Proxies

Cache documents close to **server**

→ decrease server load

- Typically done by content providers
- Only works for *static(*) content*

() static can also be snapshots of dynamic content*

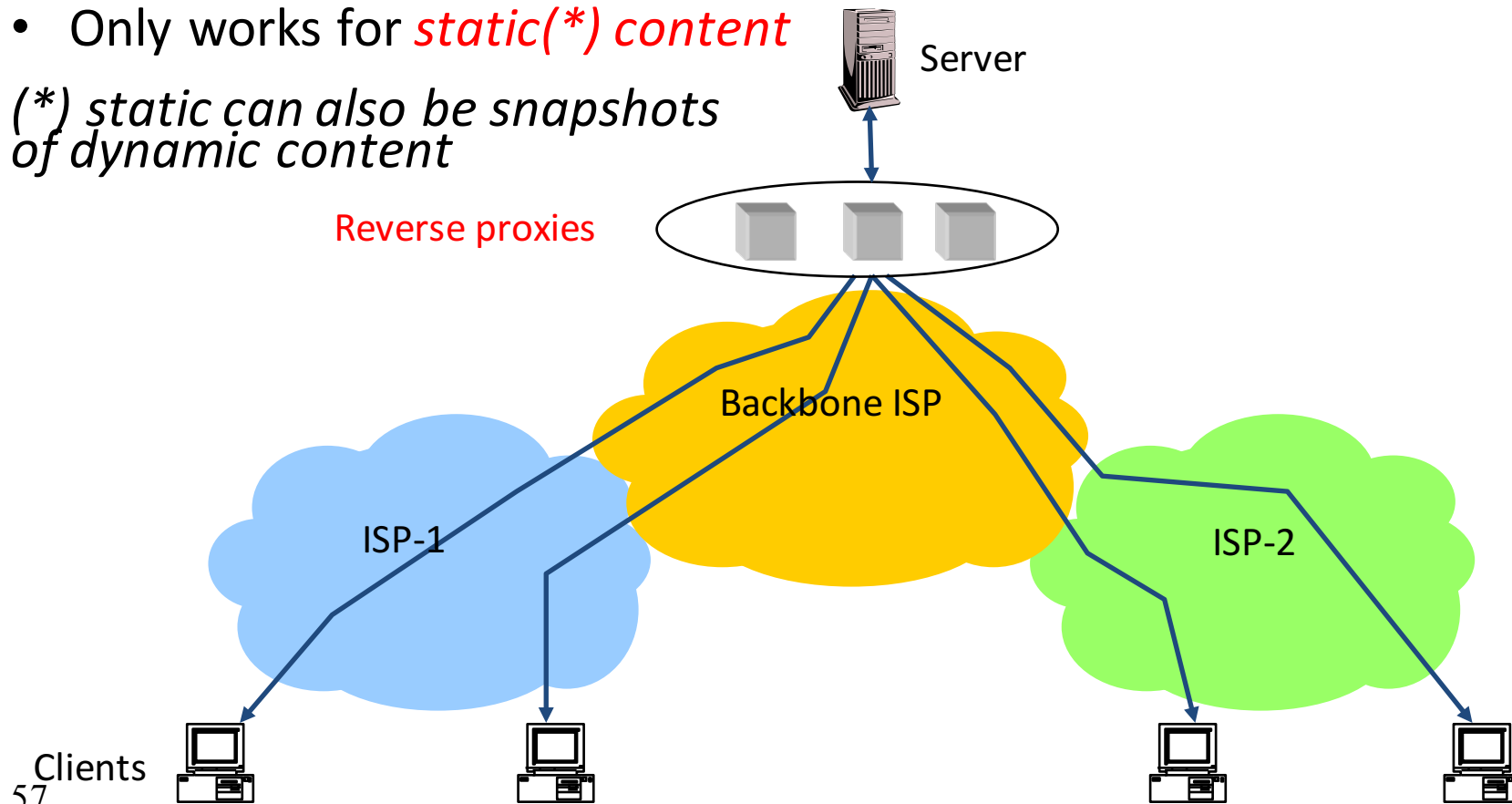

Improving HTTP Performance: Caching with Forward Proxies

Cache documents close to **clients**

→ reduce network traffic and decrease latency

- Typically done by ISPs or corporate LANs

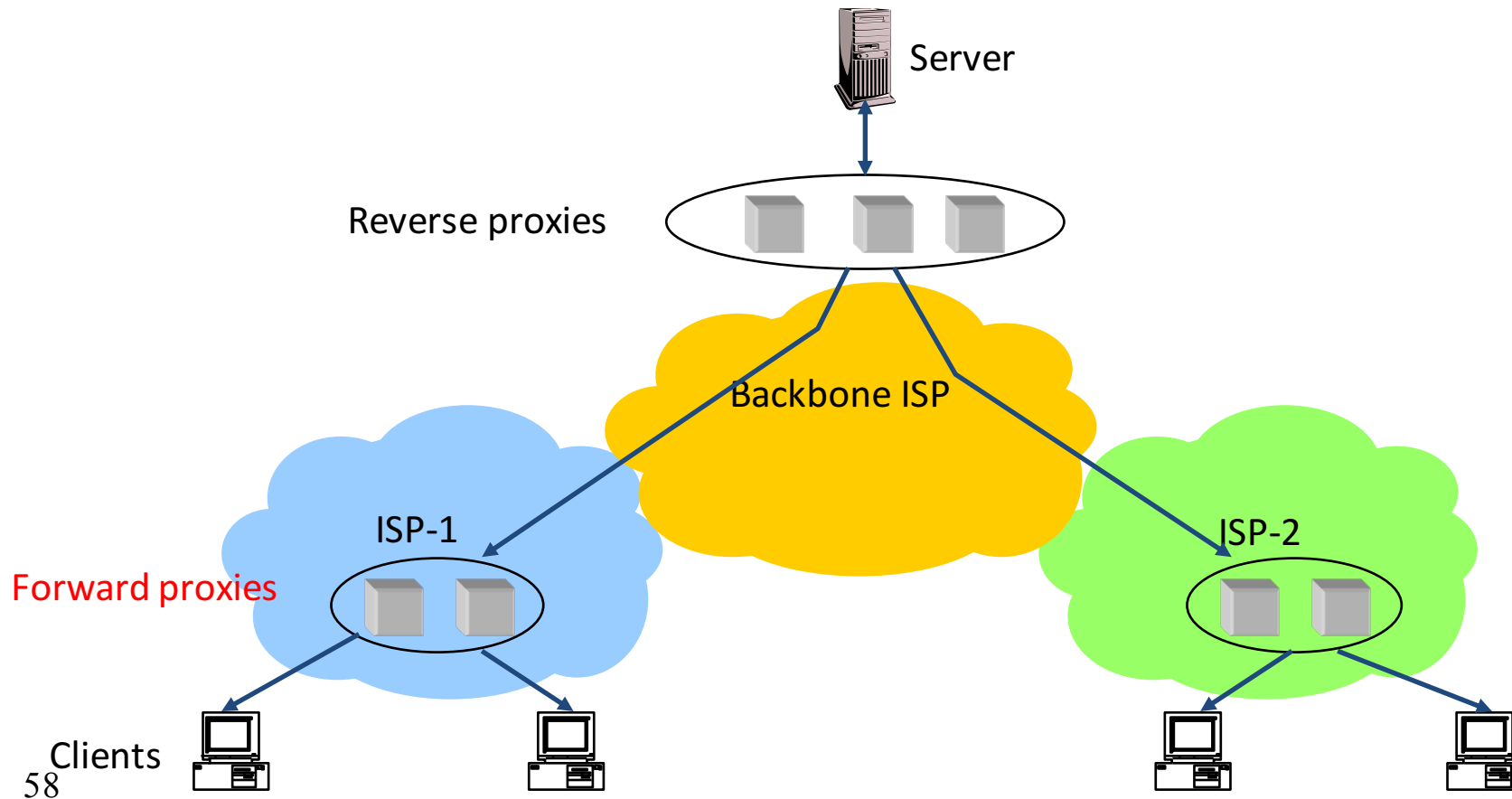

Improving HTTP Performance:

Caching w/ Content Distribution Networks

- Integrate forward and reverse caching functionality
 - One overlay network (usually) administered by one entity
 - *e.g.*, Akamai
- Provide document caching
 - **Pull:** Direct result of clients' requests
 - **Push:** Expectation of high access rate
- Also do some processing
 - Handle *dynamic* web pages
 - *Transcoding*
 - *Maybe do some security function – watermark IP*

Improving HTTP Performance: Caching with CDNs (cont.)

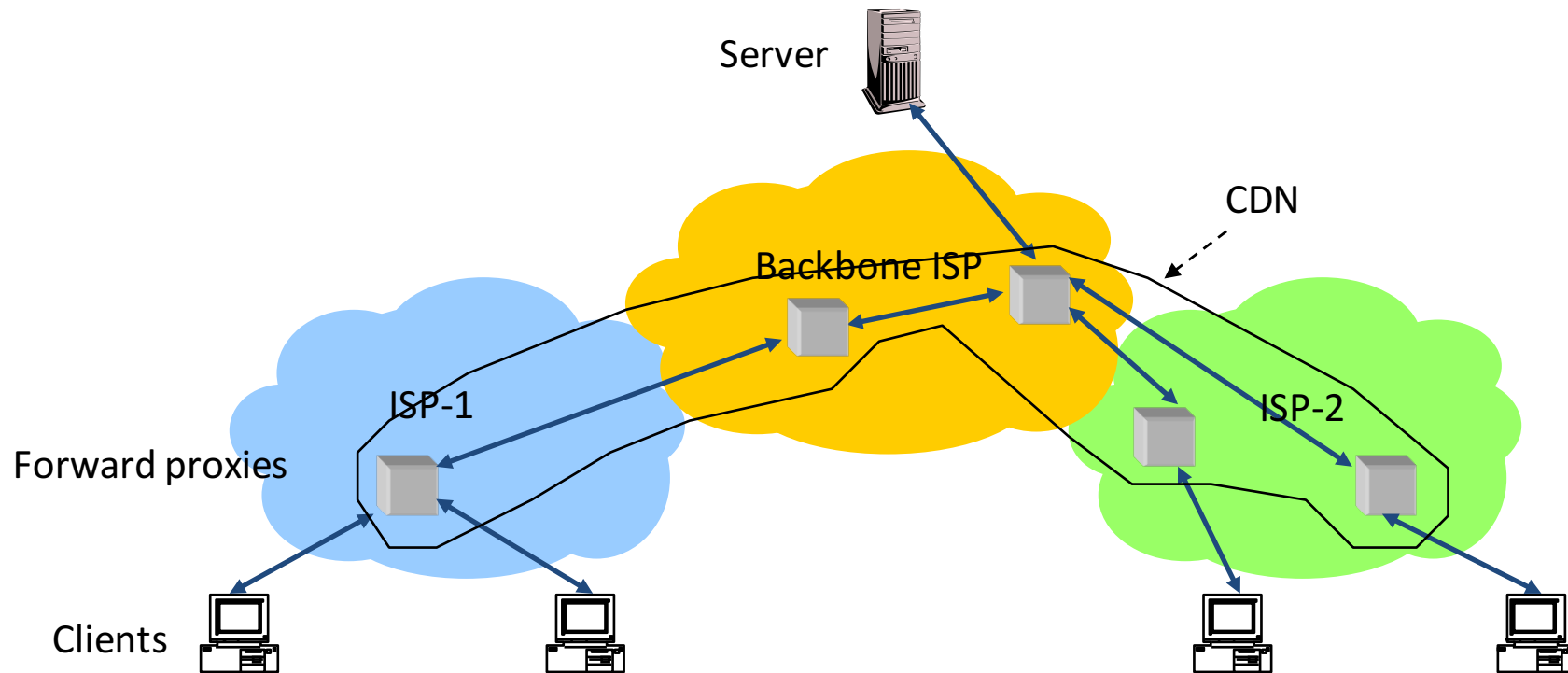

Improving HTTP Performance:
CDN Example – Akamai

- Akamai creates new domain names for each client content provider.
 - e.g., a128.g.akamai.net
- The CDN's DNS servers are authoritative for the new domains
- The client content provider modifies its content so that embedded URLs reference the new domains.
 - “Akamaize” content
 - e.g.: <http://www.bbc.co.uk/popular-image.jpg> becomes <http://a128.g.akamai.net/popular-image.jpg>
- *Requests now sent to CDN's infrastructure...*

Hosting: Multiple Sites Per Machine

- Multiple Web sites on a single machine
 - Hosting company runs the Web server on behalf of multiple sites (*e.g.*, `www.foo.com` and `www.bar.com`)
- Problem: `GET /index.html`
 - `www.foo.com/index.html` Or `www.bar.com/index.html`?
- Solutions:
 - Multiple server processes on the same machine
 - Have a separate IP address (or port) for each server
 - Include site name in HTTP request
 - Single Web server process with a single IP address
 - Client includes “Host” header (*e.g.*, `Host: www.foo.com`)
 - *Required header* with HTTP/1.1

Hosting: Multiple Machines Per Site

- Replicate popular Web site across many machines
 - Helps to handle the load
 - Places content closer to clients
- Helps when content isn't cacheable
- Problem: Want to direct client to particular replica
 - Balance load across server replicas
 - Pair clients with nearby servers

Multi-Hosting at Single Location

- Single IP address, multiple machines
 - Run multiple machines behind a single IP address

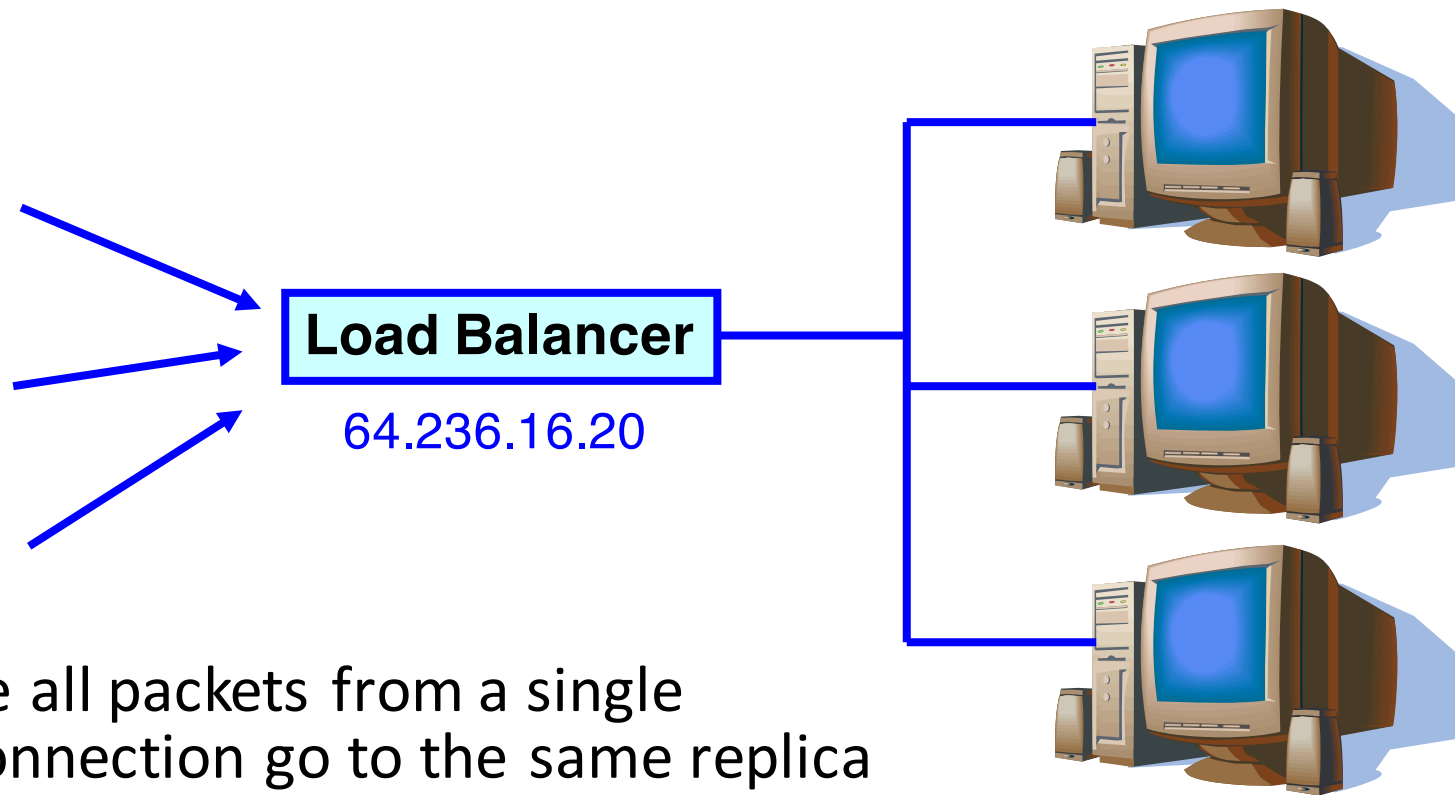

- Ensure all packets from a single TCP connection go to the same replica

Multi-Hosting at Several Locations

- Multiple addresses, multiple machines
 - Same name but different addresses for all of the replicas
 - Configure DNS server to return *closest* address

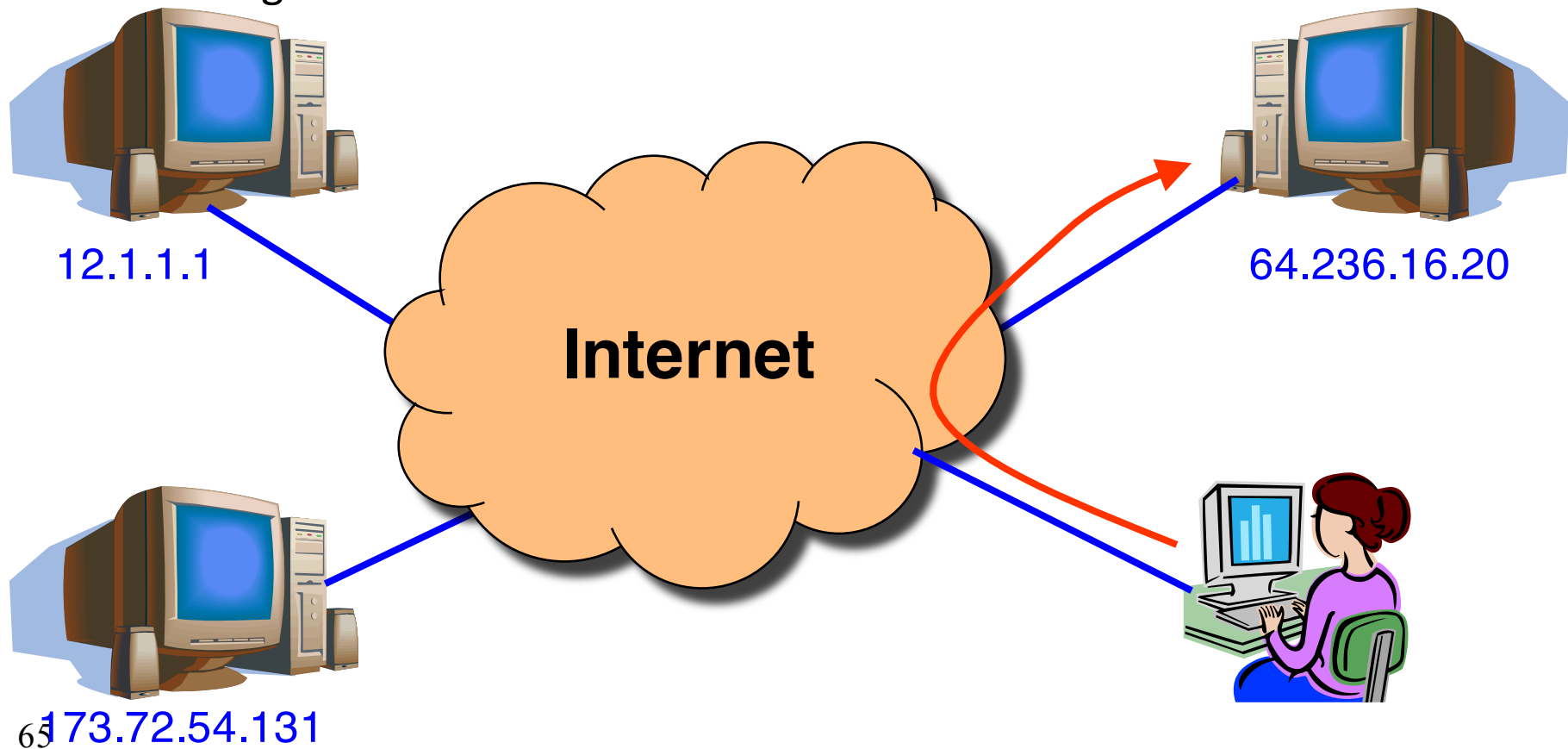

CDN examples round-up

- CDN using DNS
DNS has information on loading/distribution/location
- CDN using anycast
same address from DNS name but local routes
- CDN based on rewriting HTML URLs
(akami example just covered – akami uses DNS too)

SIP – Session Initiation Protocol

Session?

Anyone smell an OSI / ISO standards document burning?

SIP - VoIP

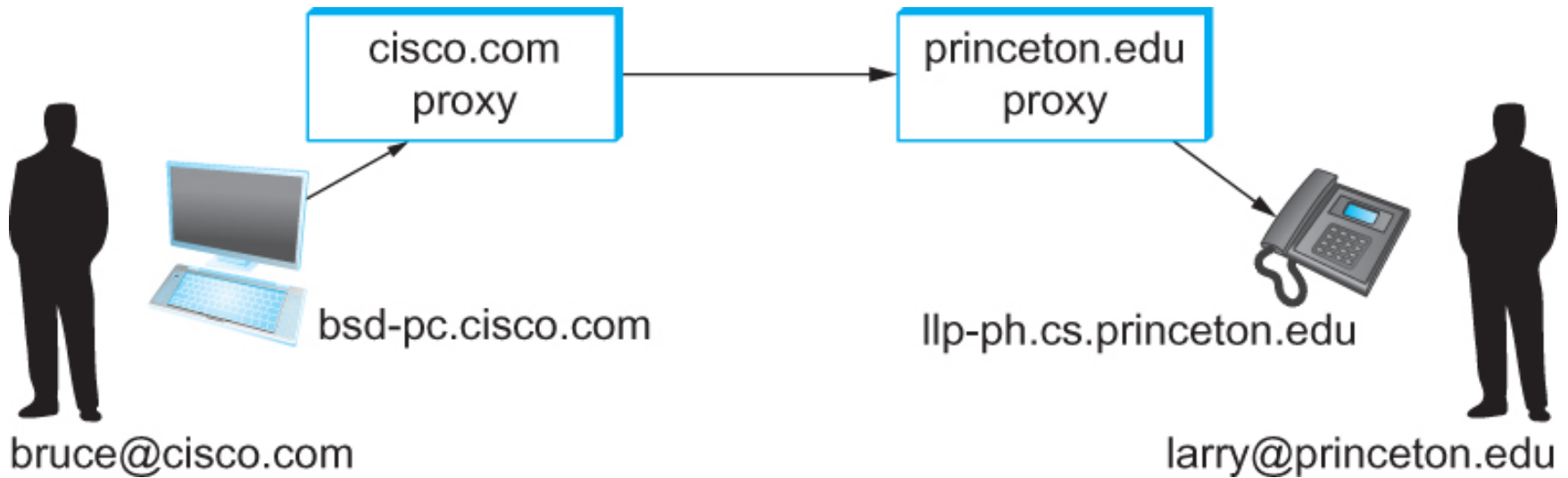

Establishing communication through SIP proxies.



SIP?

- SIP – bringing the fun/complexity of telephony to the Internet
 - User location
 - User availability
 - User capabilities
 - Session setup
 - Session management
 - (e.g. “call forwarding”)

H.323 – ITU

- Why have one standard when there are at least two....
- The full H.323 is hundreds of pages
 - The protocol is known for its complexity – an ITU hallmark
- SIP is not much better
 - IETF grew up and became the ITU....

Multimedia Applications

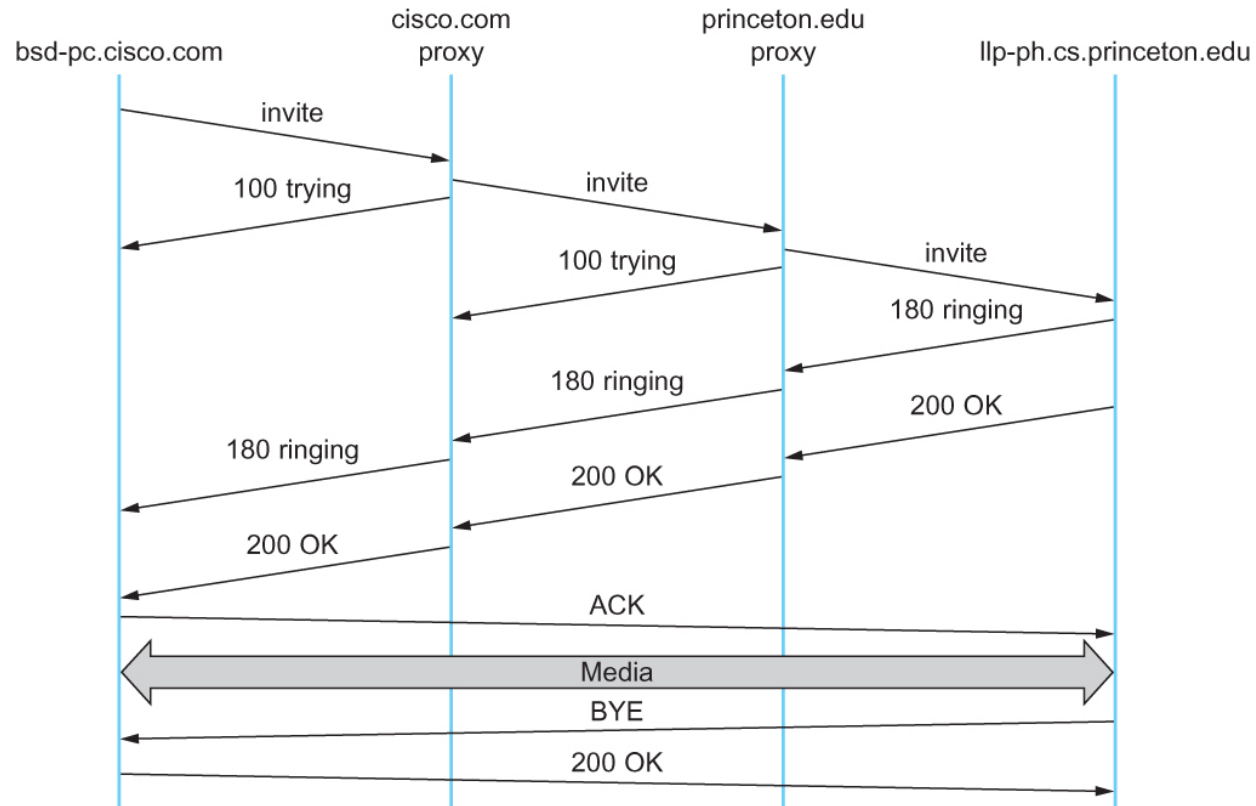

Message flow for a basic SIP session

The (still?) missing piece: Resource Allocation for Multimedia Applications

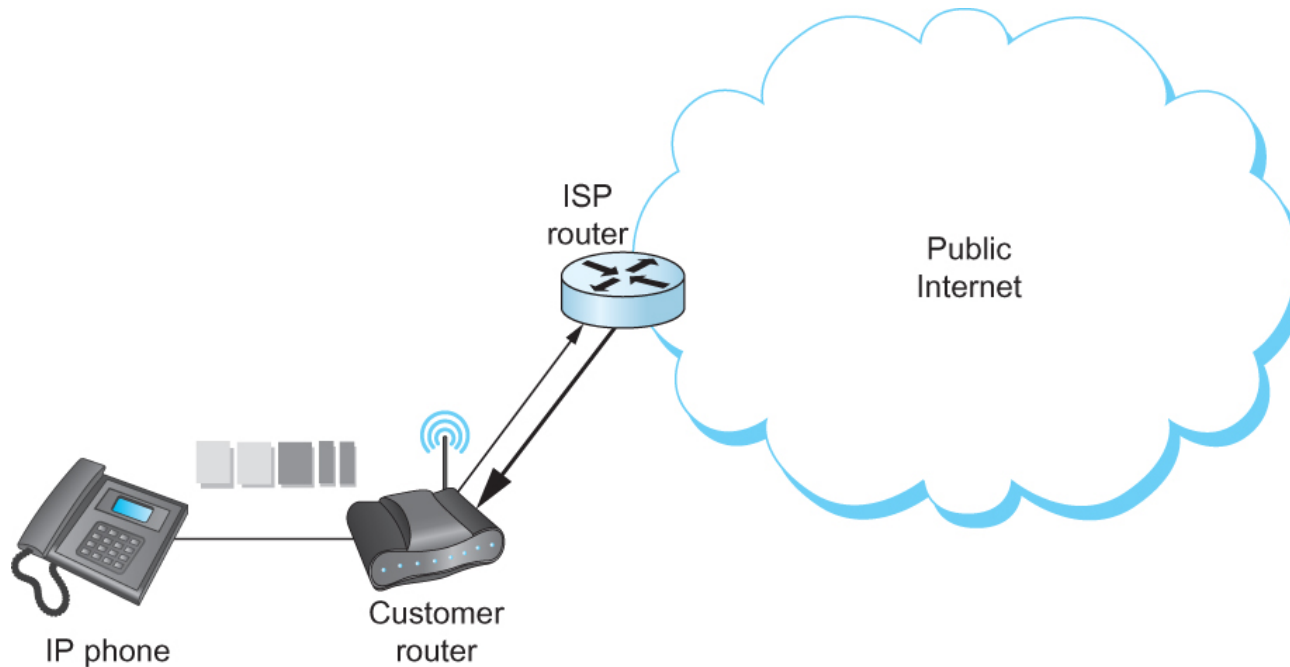

I can 'differentiate' VoIP from data but...

I can only control data going into the Internet

Multimedia Applications

- Resource Allocation for Multimedia Applications

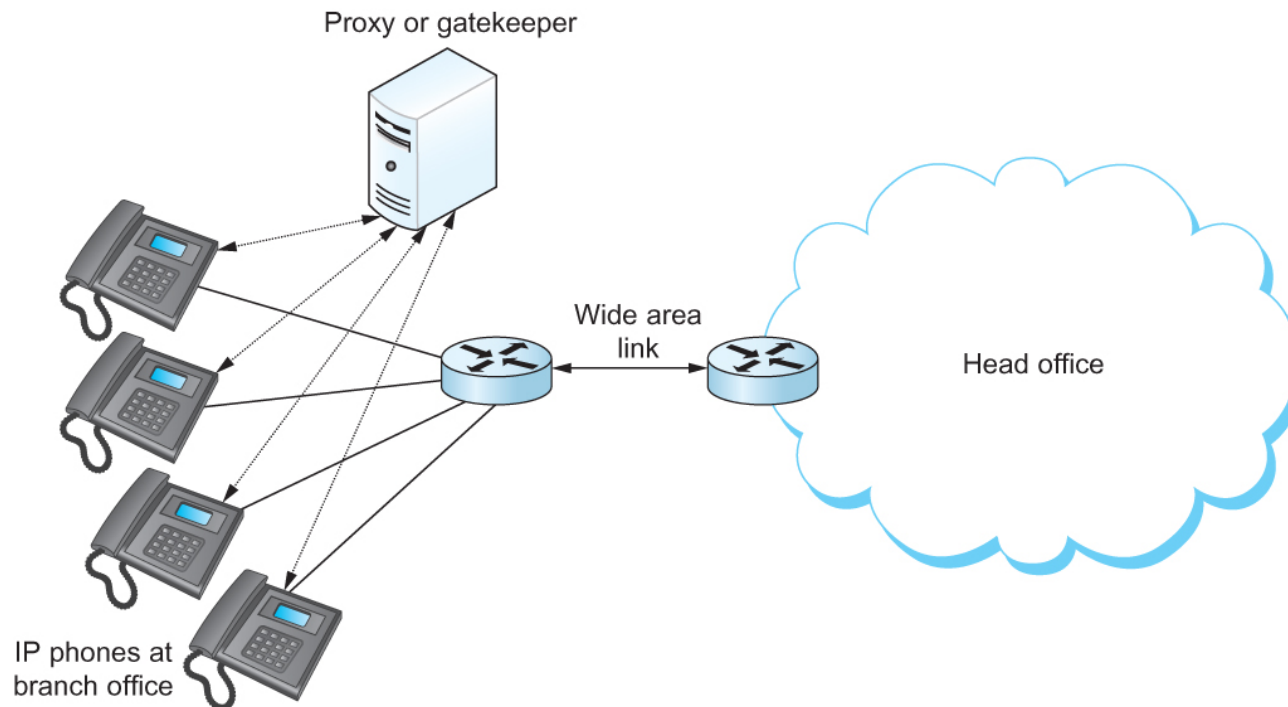

Admission control using session control protocol.

Resource Allocation for Multimedia Applications

Coming soon... ~~1995~~

~~2000~~

~~2010~~

who are we kidding??

Co-ordination of SIP signaling and resource reservation.

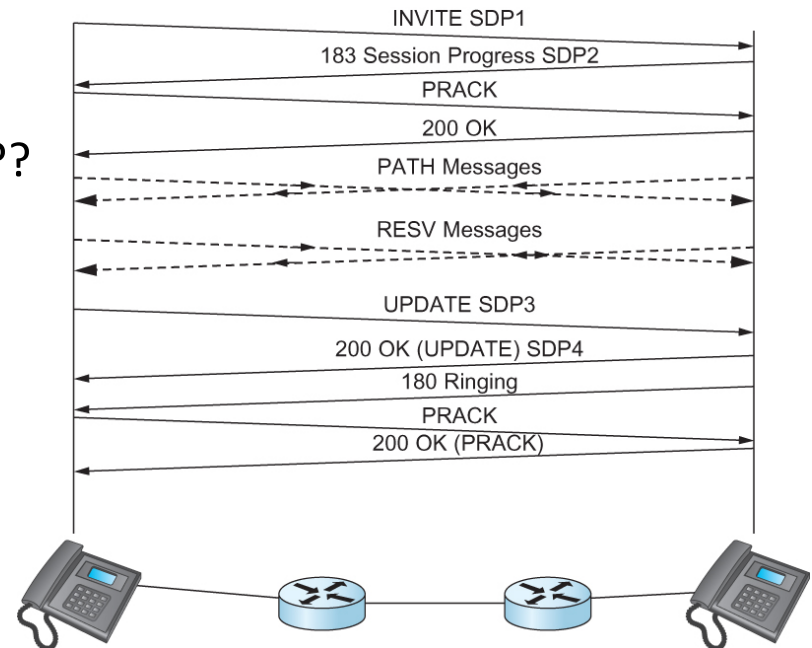

So where does it happen?

Inside single institutions or *domains of control*....

(Universities, Hospitals, big corp...)

What about my aDSL/CABLE/etc it combines voice and data?

Phone company **controls** the multiplexing on the line and throughout their own network too.....

P2P – efficient network use that
annoys the ISP

Pure P2P architecture

- *no* always-on server
- arbitrary end systems directly communicate
- peers are intermittently connected and change IP addresses
- Three topics:
 - File distribution
 - Searching for information
 - Case Study: Skype

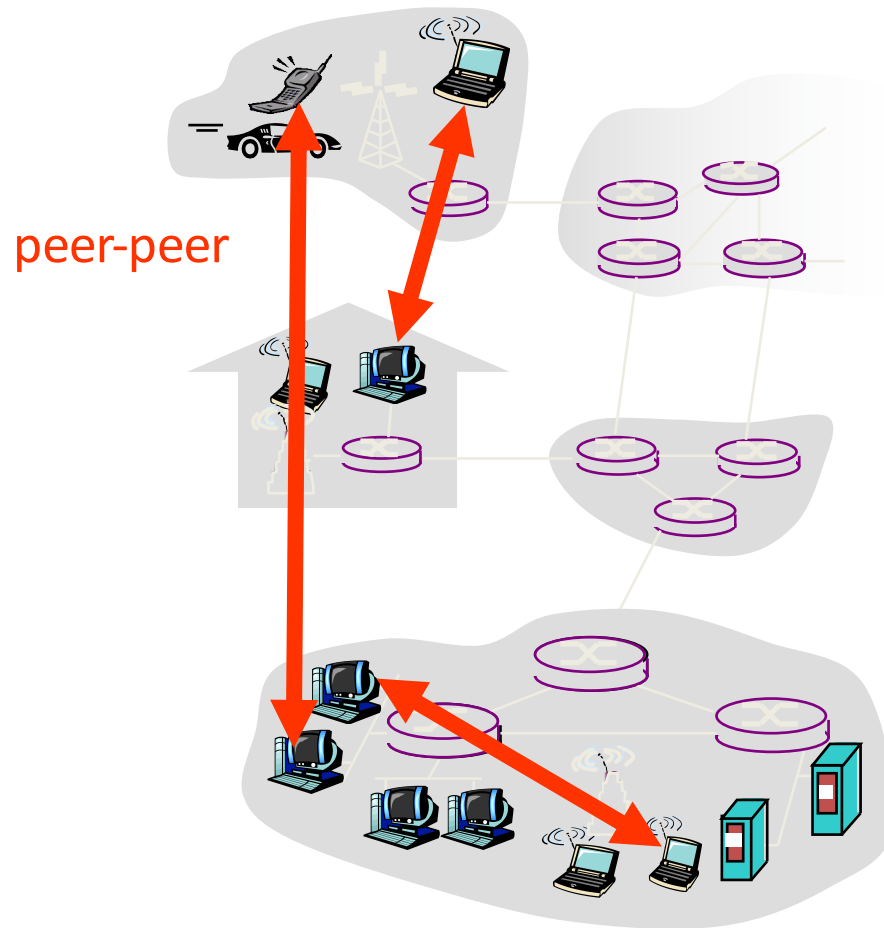

File Distribution: Server-Client vs P2P

Question : How much time to distribute file from one server to N peers?

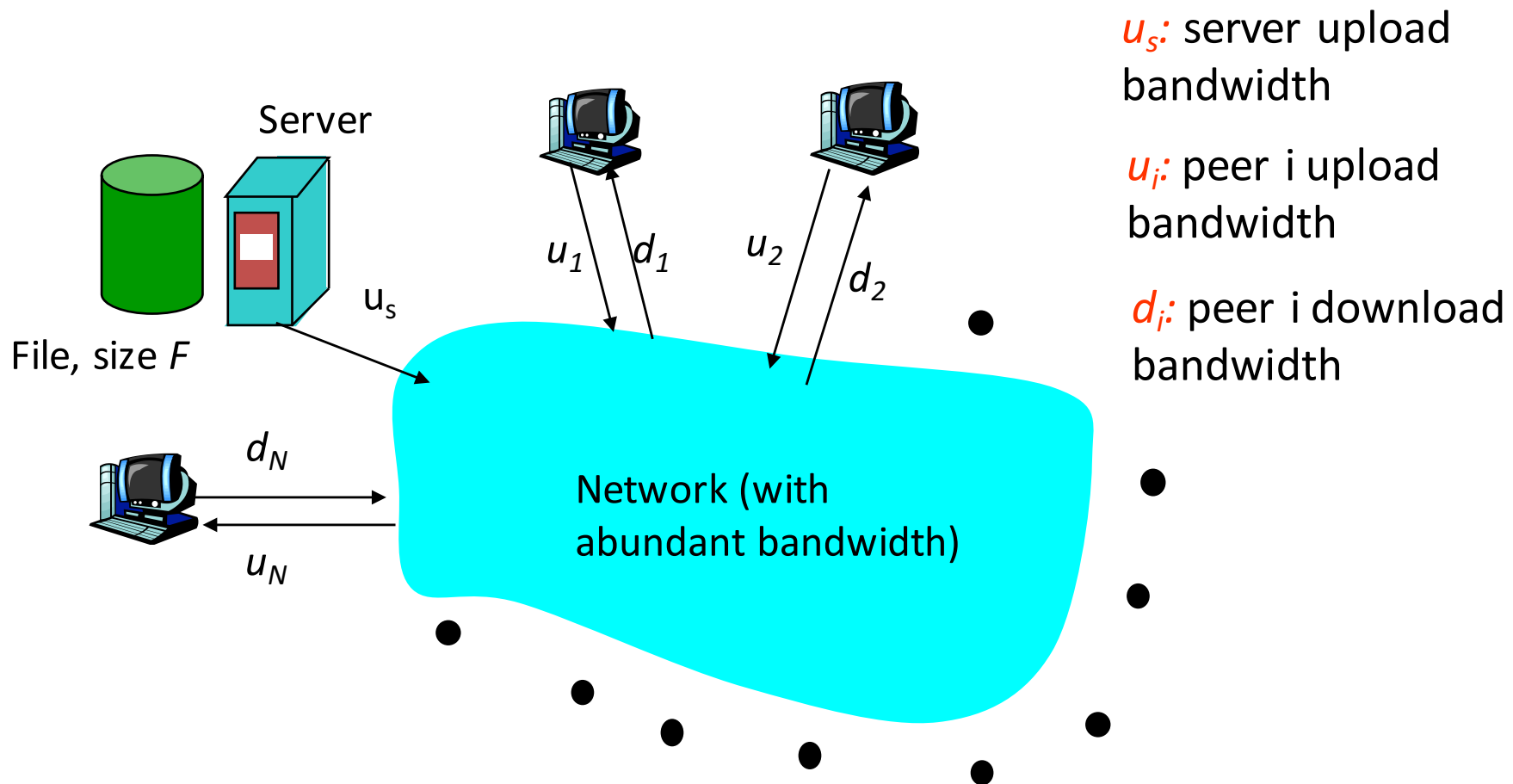

File distribution time: server-client

- server sequentially sends N copies:
 - NF/u_s time
- client i takes F/d_i time to download

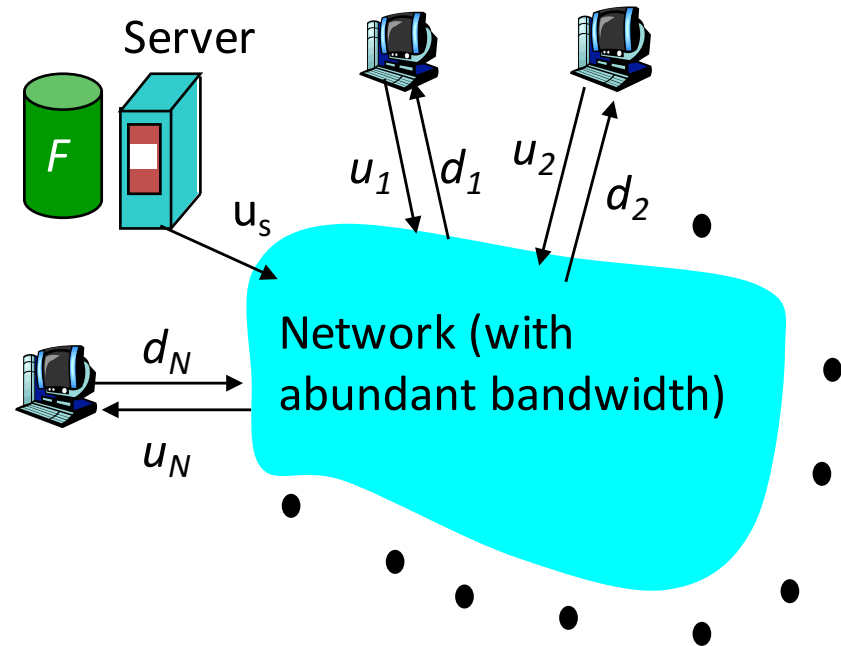

Time to distribute F to N clients using client/server approach = $d_{cs} = \max \left\{ NF/u_s, F/\min(d_i) \right\}$

increases linearly in N (for large N)

File distribution time: P2P

- server must send one copy:
 F/u_s time
- client i takes F/d_i time to download
- NF bits must be downloaded (aggregate)
 - fastest possible upload rate: $u_s + \sum u_i$

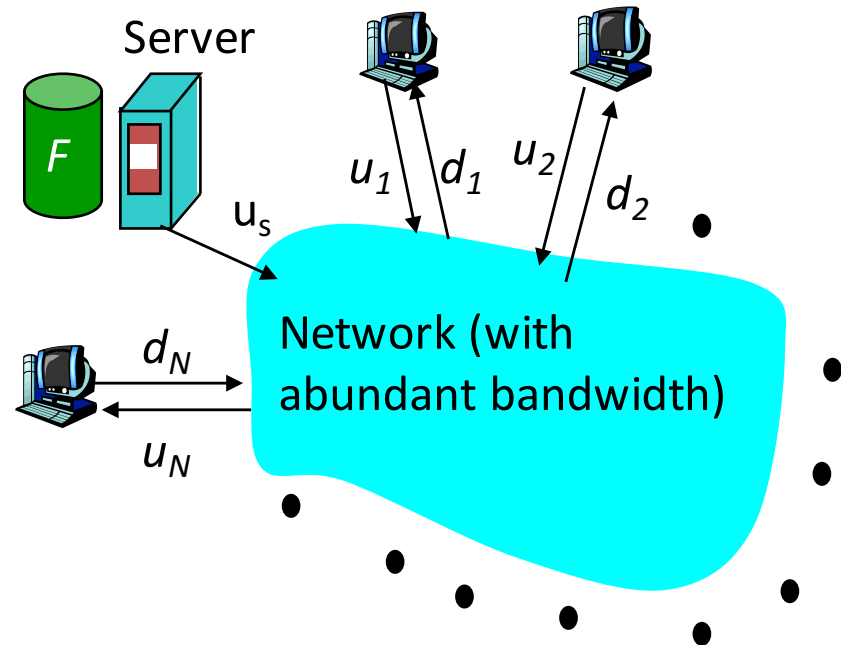

$$d_{\text{P2P}} = \max \left\{ F/u_s, F/\min(d_i), NF/(u_s + \sum u_i) \right\}$$

Server-client vs. P2P: example

Client upload rate = u , $F/u = 1$ hour, $u_s = 10u$, $d_{\min} \geq u_s$

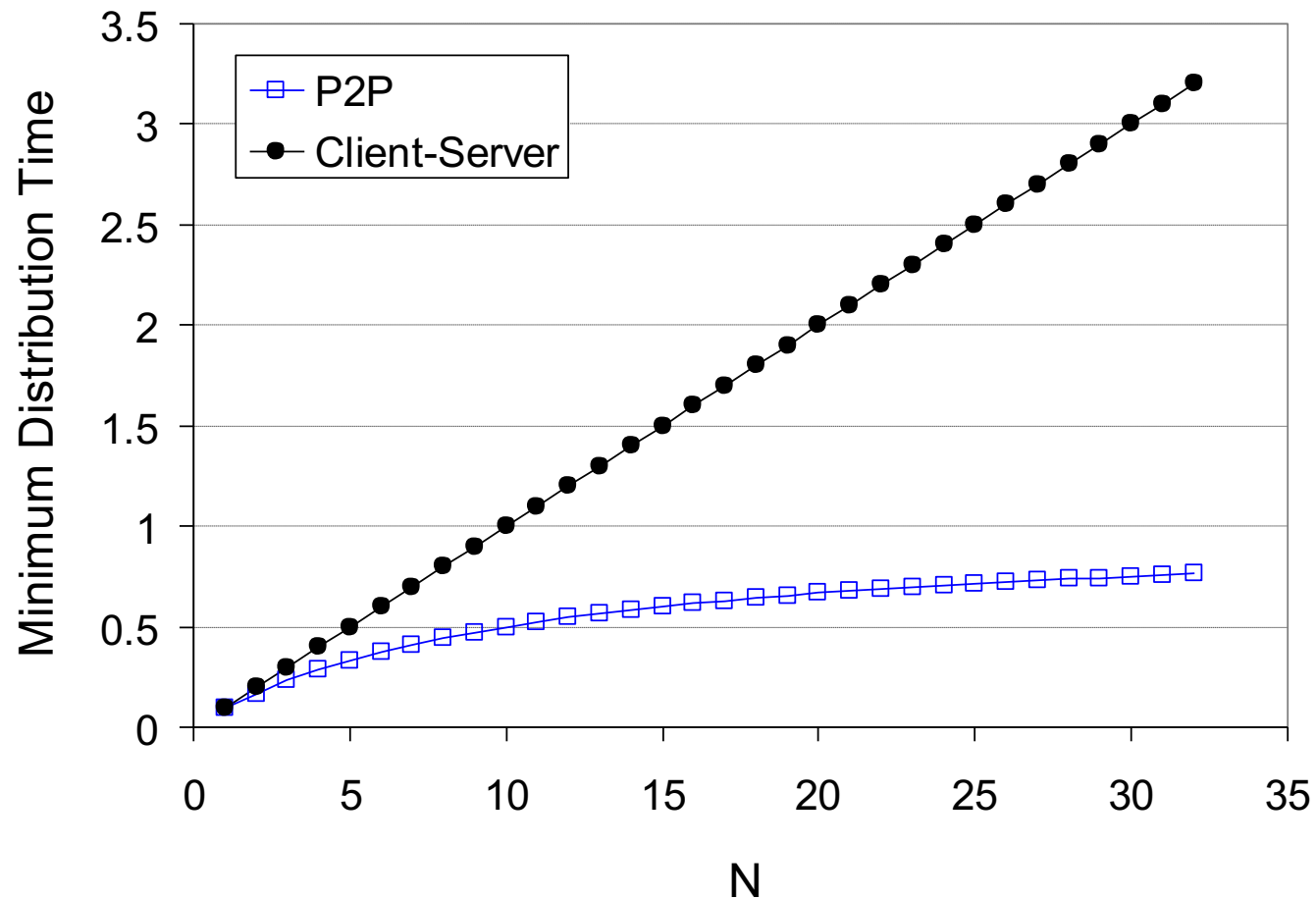

File distribution: BitTorrent*

*rather old BitTorrent

- P2P file distribution

tracker: tracks peers
participating in torrent

torrent: group of
peers exchanging
chunks of a file

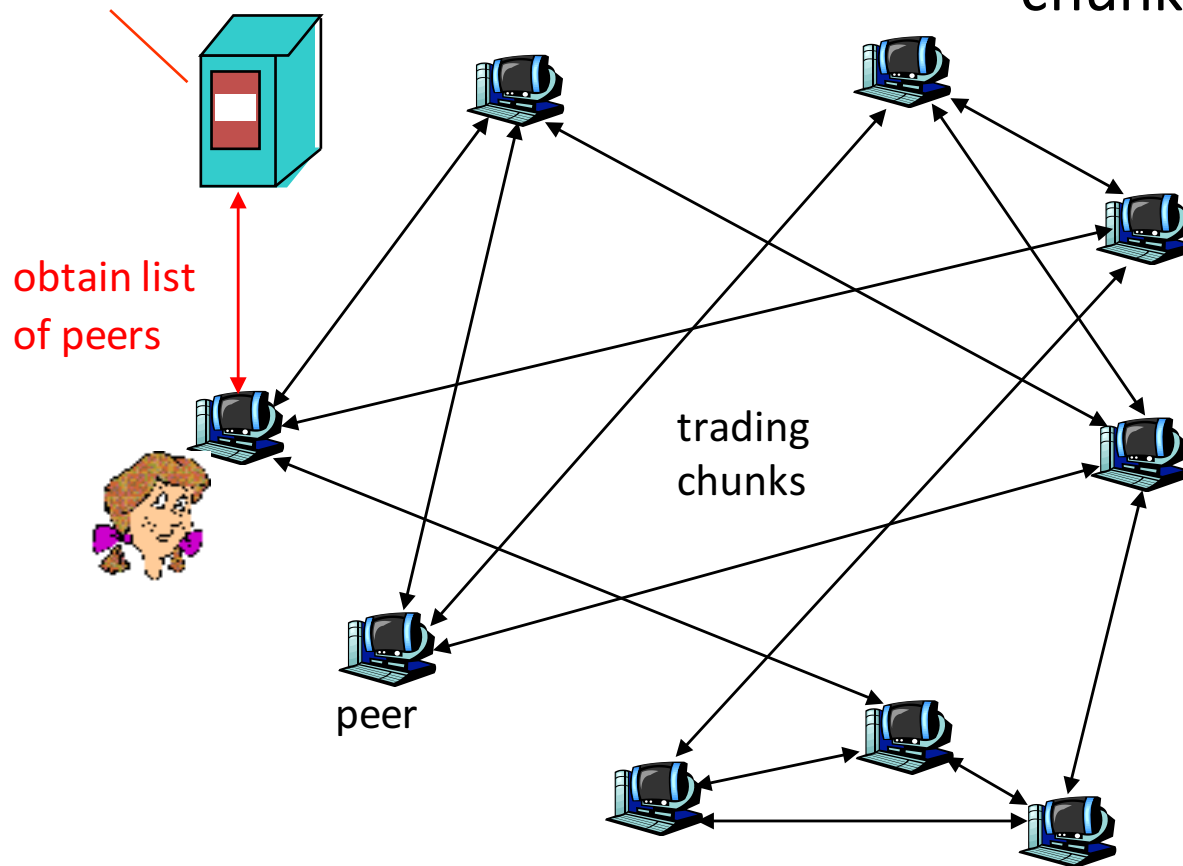

BitTorrent (1)

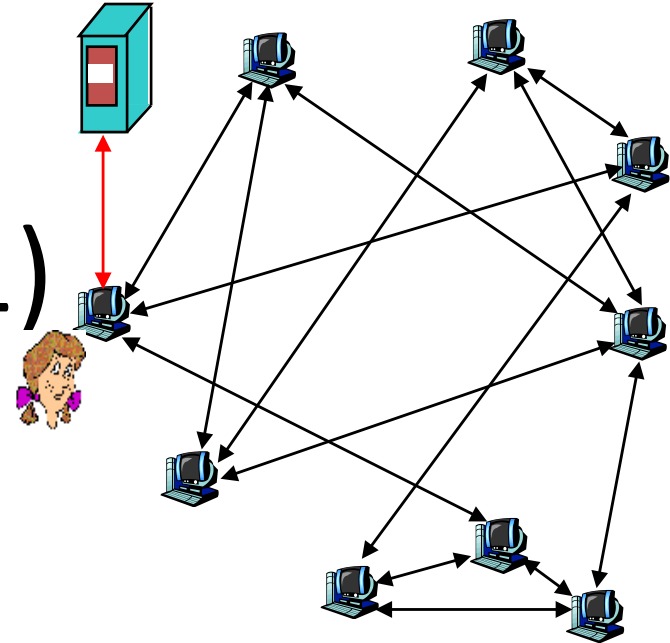

- file divided into 256KB *chunks*.
- peer joining torrent:
 - has no chunks, but will accumulate them over time
 - registers with tracker to get list of peers, connects to subset of peers (“neighbors”)
- while downloading, peer uploads chunks to other peers.
- peers may come and go
- once peer has entire file, it may (selfishly) leave or (altruistically) remain

BitTorrent (2)

Pulling Chunks

- at any given time, different peers have different subsets of file chunks
- periodically, a peer (Alice) asks each neighbor for list of chunks that they have.
- Alice sends requests for her missing chunks
 - rarest first

Sending Chunks: tit-for-tat

- ❑ Alice sends chunks to four neighbors currently sending her chunks *at the highest rate*
 - ❖ re-evaluate top 4 every 10 secs
- ❑ every 30 secs: randomly select another peer, starts sending chunks
 - ❖ newly chosen peer may join top 4
 - ❖ “optimistically unchoke”

BitTorrent: Tit-for-tat

- (1) Alice “optimistically unchokes” Bob
- (2) Alice becomes one of Bob’s top-four providers; Bob reciprocates
- (3) Bob becomes one of Alice’s top-four providers

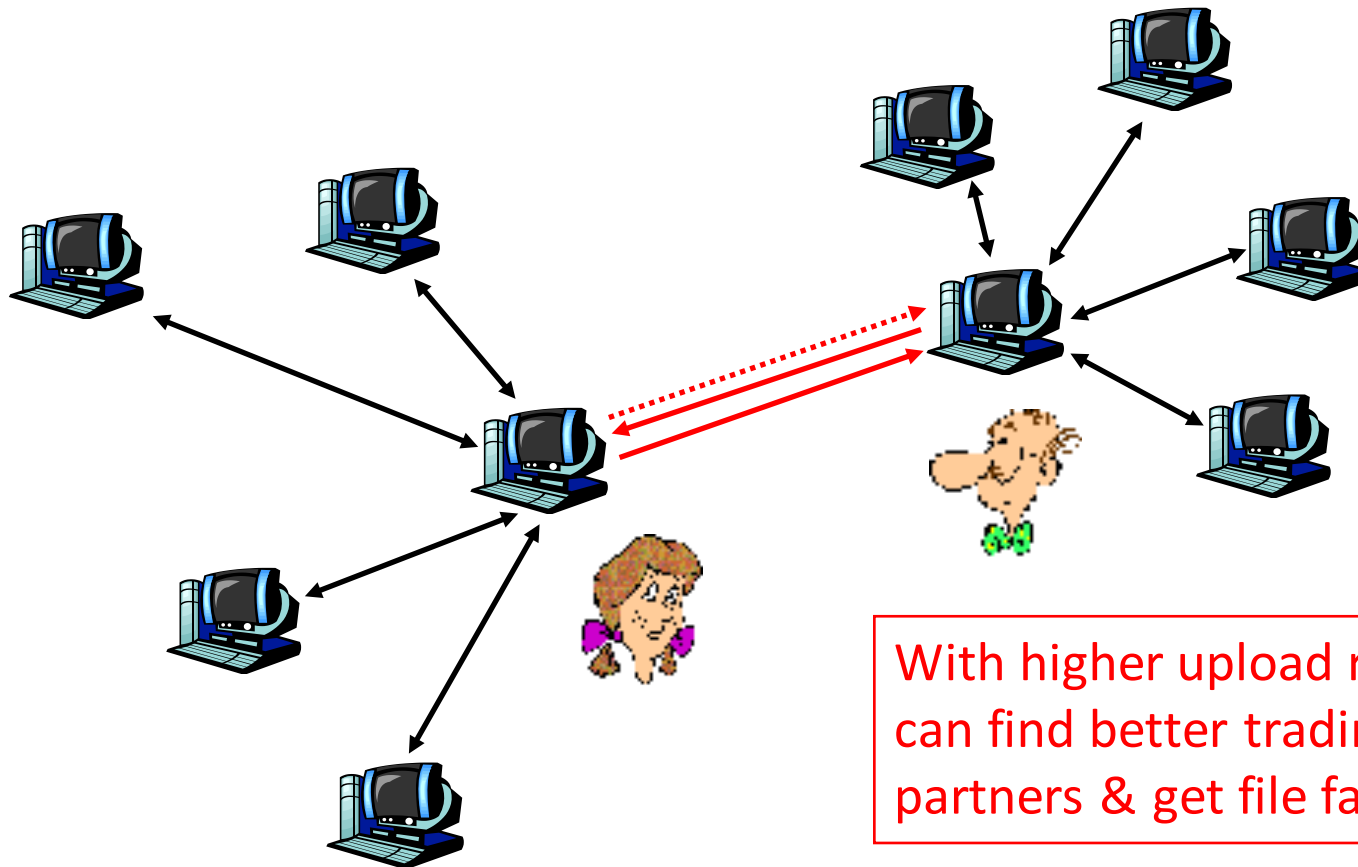

With higher upload rate,
can find better trading
partners & get file faster!

Distributed Hash Table (DHT)

- DHT = distributed P2P database
- Database has (key, value) pairs;
 - key: ss number; value: human name
 - key: content type; value: IP address
- Peers query DB with key
 - DB returns values that match the key
- Peers can also insert (key, value) peers

Distributed Hash Table (DHT)

- DHT = distributed P2P database
- Database has **(key, value)** pairs;
 - key: ss number; value: human name
 - key: content type; value: IP address
- Peers **query** DB with key
 - DB returns values that match the key
- Peers can also **insert** (key, value) peers

DHT Identifiers

- Assign integer identifier to each peer in range $[0, 2^n - 1]$.
 - Each identifier can be represented by n bits.
- Require each key to be an integer in **same range**.
- To get integer keys, hash original key.
 - eg, key = $h(\text{"Game of Thrones season 4"})$
 - This is why they call it a distributed "hash" table

How to assign keys to peers?

- Central issue:
 - Assigning (key, value) pairs to peers.
- Rule: assign key to the peer that has the **closest** ID.
- Convention in lecture: closest is the **immediate successor** of the key.
- Ex: $n=4$; peers: 1,3,4,5,8,10,12,14;
 - key = 13, then successor peer = 14
 - key = 15, then successor peer = 1

Circular DHT (1)

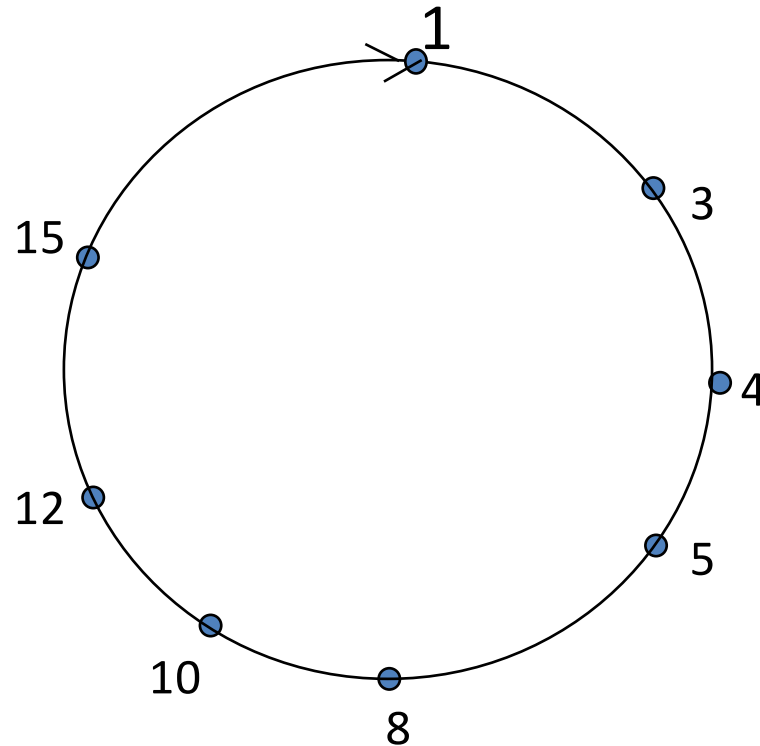

- Each peer *only* aware of immediate successor and predecessor.
- “Overlay network”

Circle DHT (2)

$O(N)$ messages
on avg to resolve
query, when there
are N peers

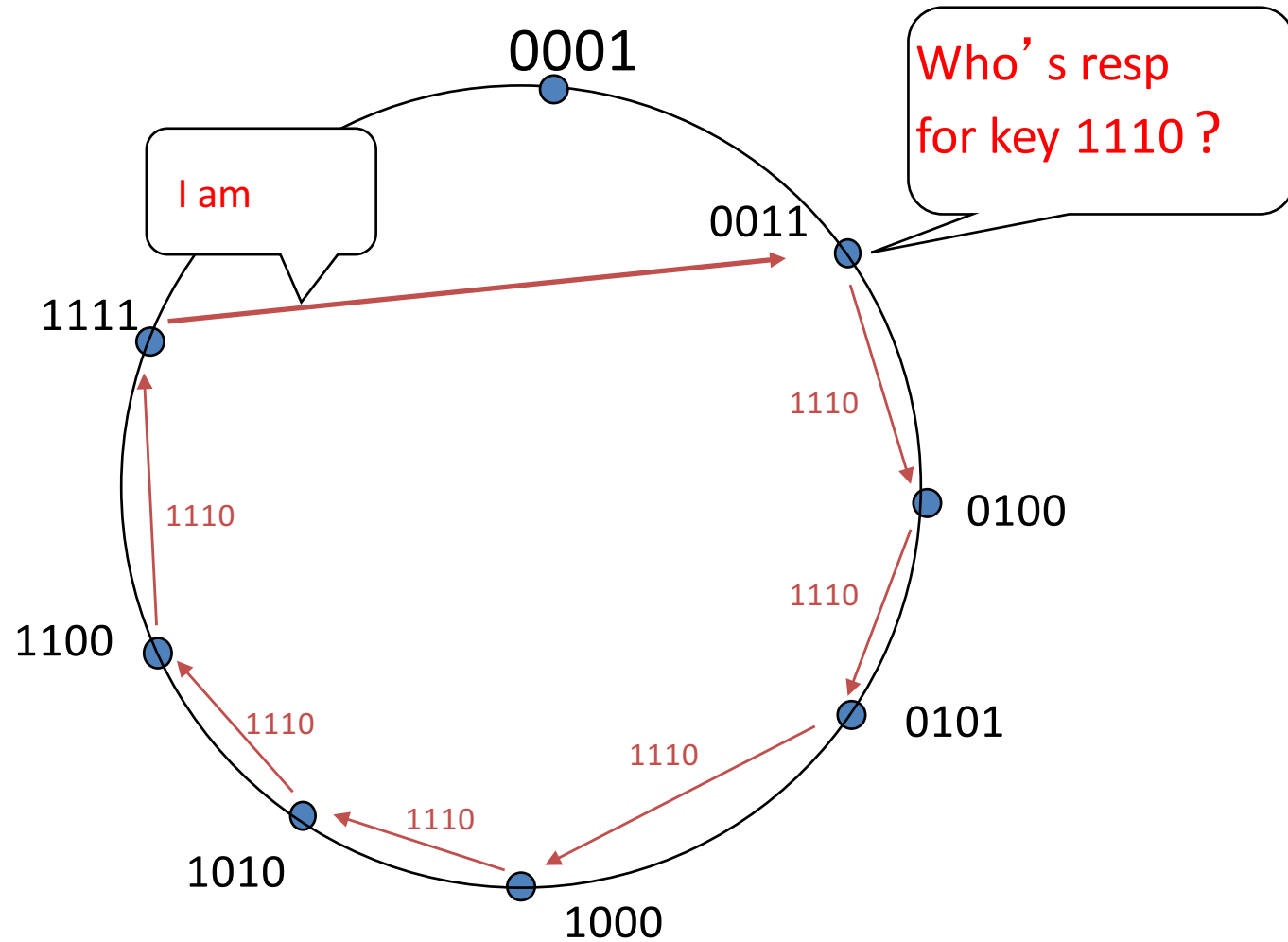

Define closest
as closest
successor

Circular DHT with Shortcuts

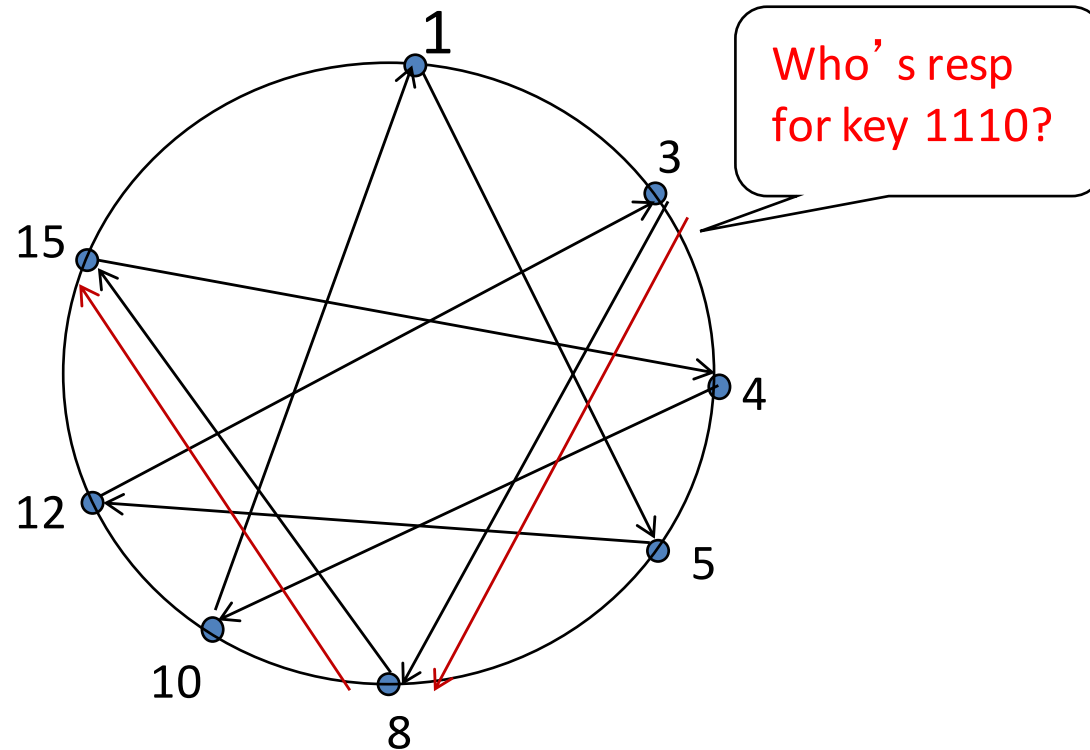

- Each peer keeps track of IP addresses of predecessor, successor, short cuts.
- Reduced from 6 to 2 messages.
- Possible to design shortcuts so $O(\log N)$ neighbors, $O(\log N)$ messages in query

Peer Churn

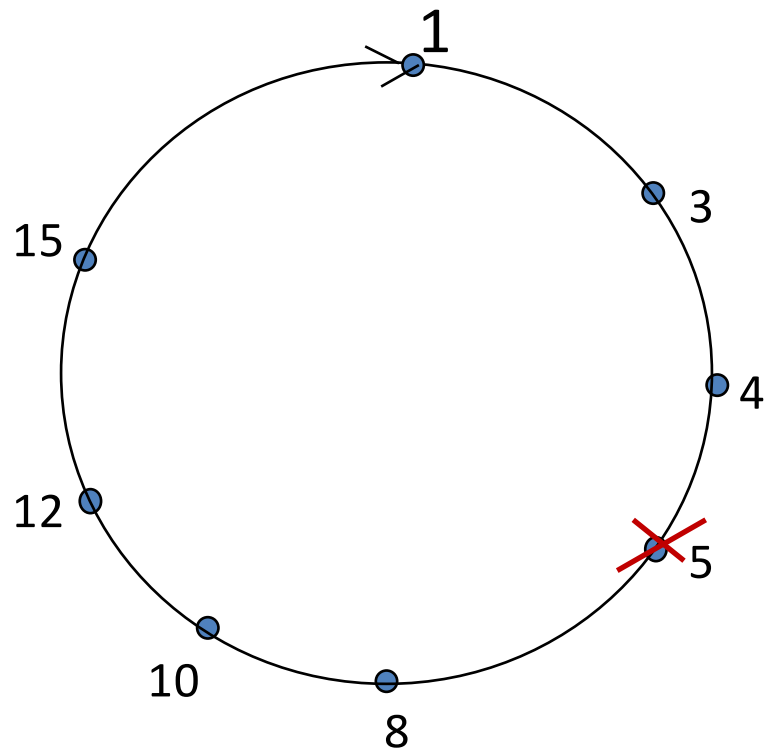

- To handle peer churn, require each peer to know the IP address of its two successors.
- Each peer periodically pings its two successors to see if they are still alive.

- Peer 5 abruptly leaves
- Peer 4 detects; makes 8 its immediate successor; asks 8 who its immediate successor is; makes 8's immediate successor its second successor.
- What if peer 13 wants to join?

P2P Case study: Skype (pre-Microsoft)

- inherently P2P: pairs of users communicate.
- proprietary application-layer protocol (inferred via reverse engineering)
- hierarchical overlay with SNs
- Index maps usernames to IP addresses; distributed over SNs

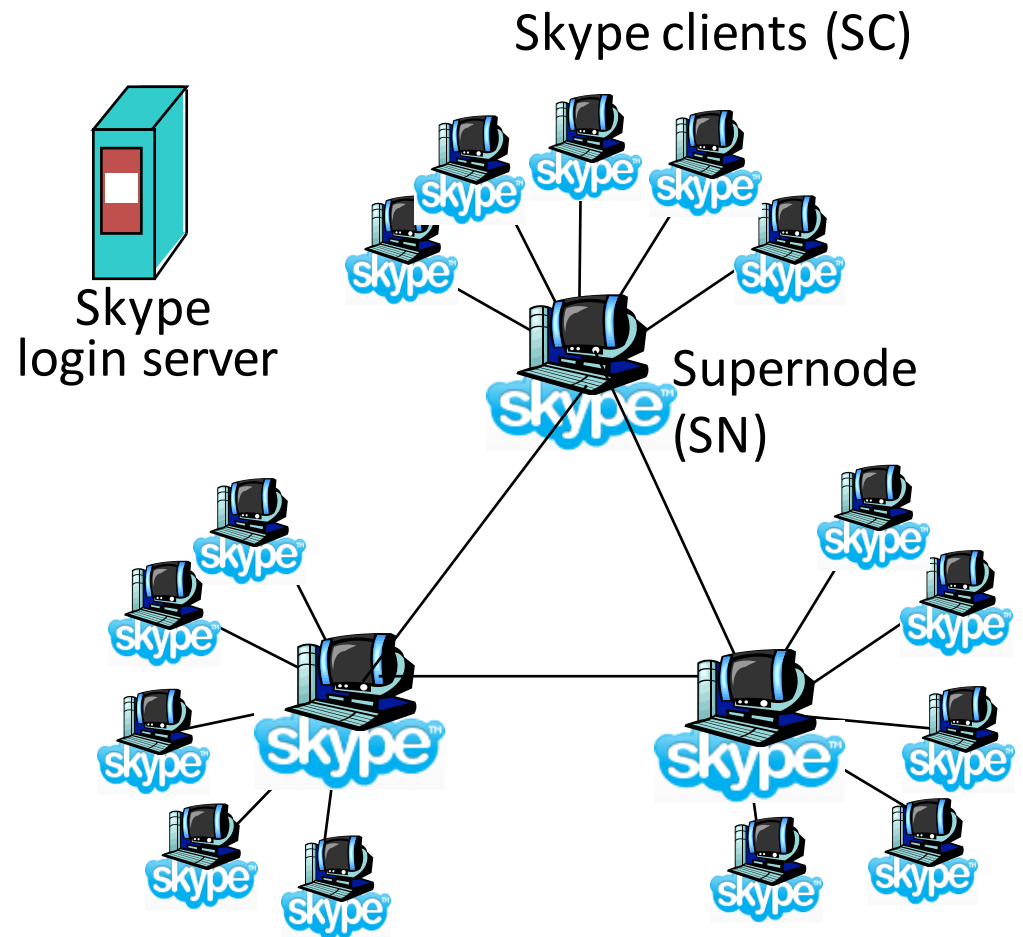

Peers as relays

- Problem when both Alice and Bob are behind “NATs”.
 - NAT prevents an outside peer from initiating a call to insider peer
- Solution:
 - Using Alice’s and Bob’s SNs, Relay is chosen
 - Each peer initiates session with relay.
 - Peers can now communicate through NATs via relay

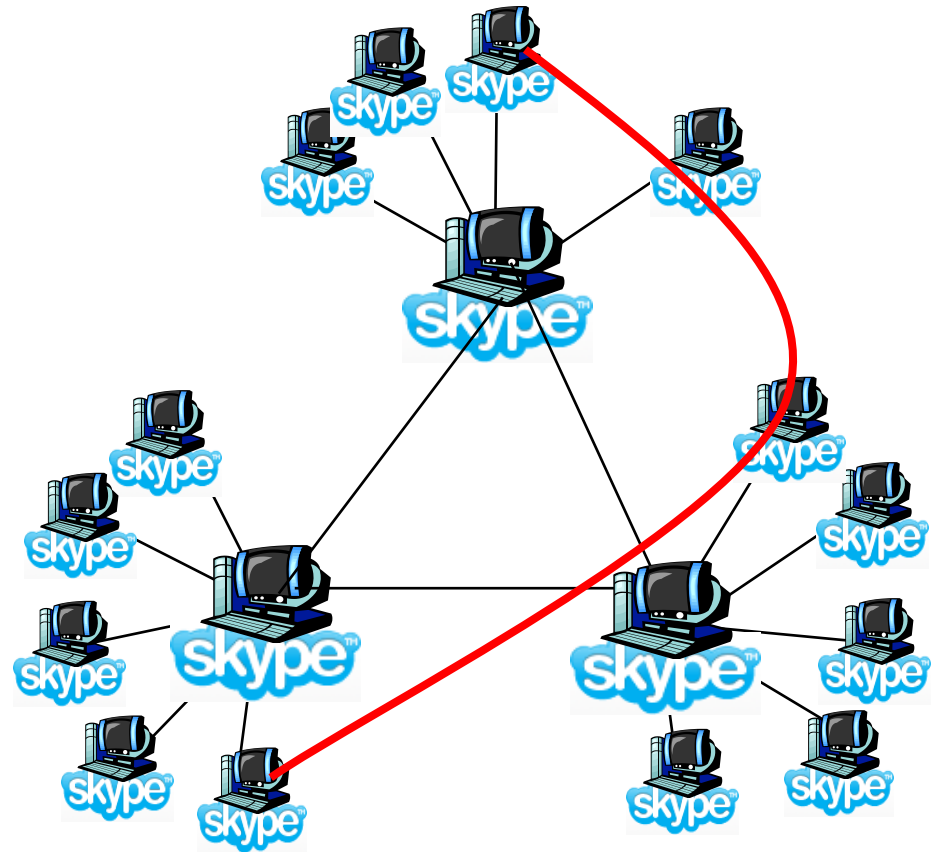

Summary.

- Apps need protocols too
- We covered examples from
 - Traditional Applications (web)
 - Scaling and Speeding the web (CDN/Cache tricks)
- Infrastructure Services (DNS)
 - Cache and Hierarchy
- Multimedia Applications (SIP)
 - Extremely hard to do better than worst-effort
- P2P Network examples