

Topic 5 – Transport

Our goals:

- understand principles behind transport layer services:
 - multiplexing/
demultiplexing
 - reliable data transfer
 - flow control
 - congestion control
- learn about transport layer protocols in the Internet:
 - UDP: connectionless transport
 - TCP: connection-oriented transport
 - TCP congestion control

Transport Layer

- Commonly a layer **at end-hosts**, between the application and network layer

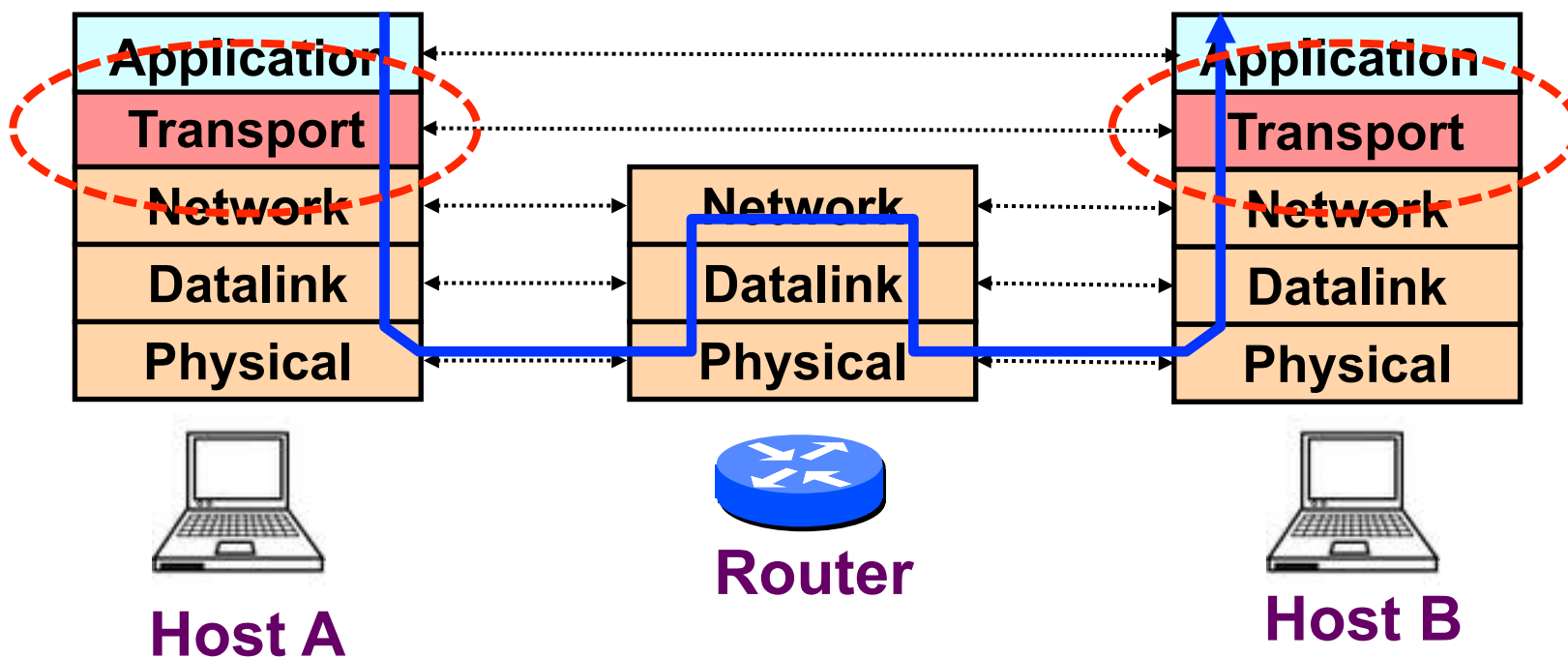

Why a transport layer?

- IP packets are addressed to a host but end-to-end communication is between application processes at hosts
 - Need a way to decide which packets go to which applications (*more multiplexing*)

Why a transport layer?

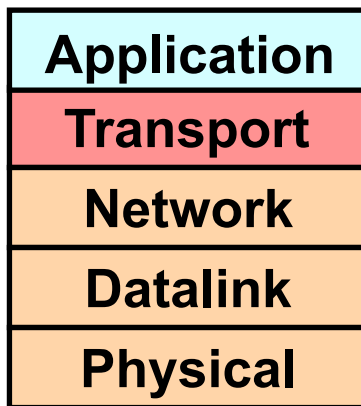

Host A

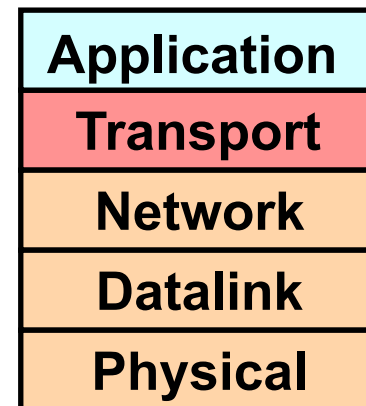

Host B

Why a transport layer?

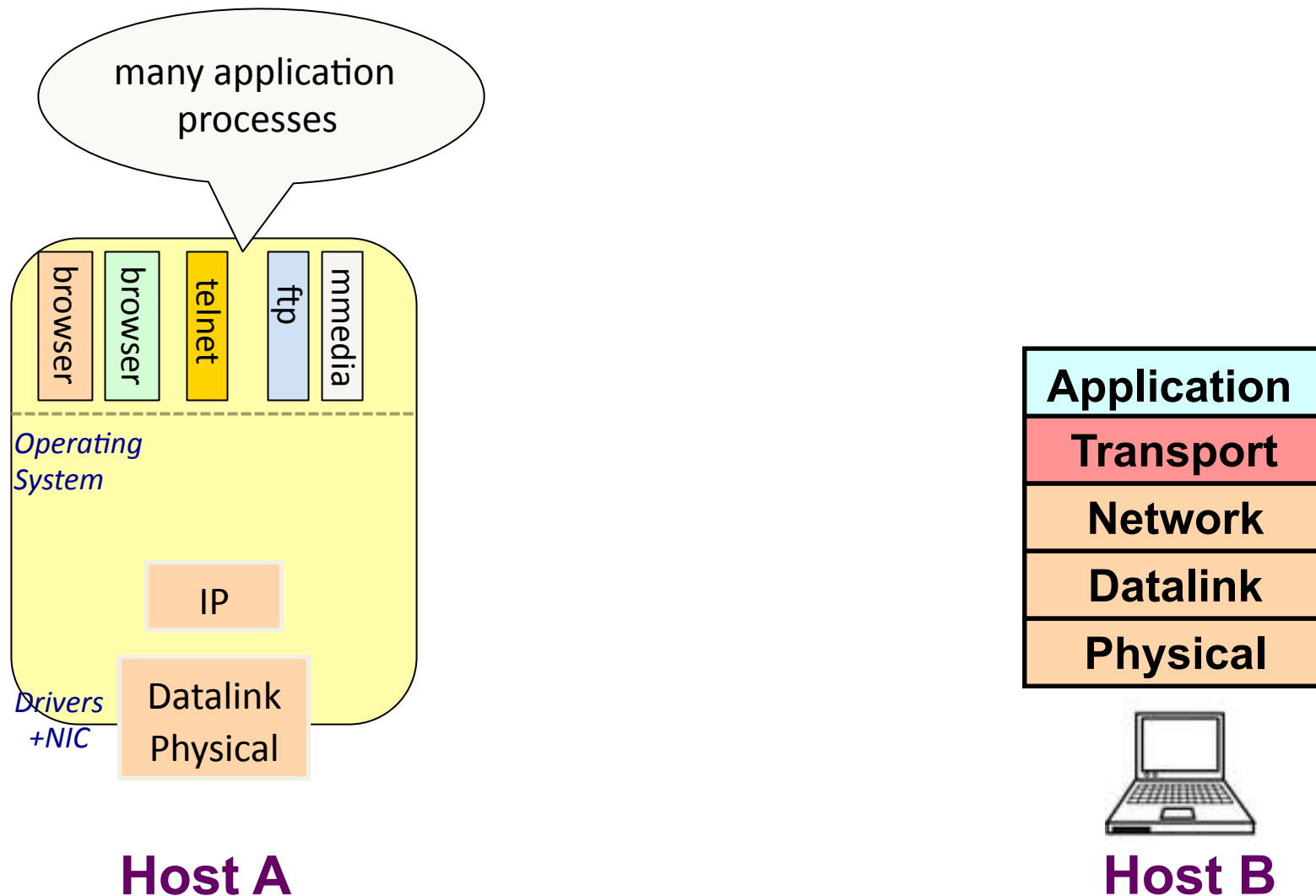

Why a transport layer?

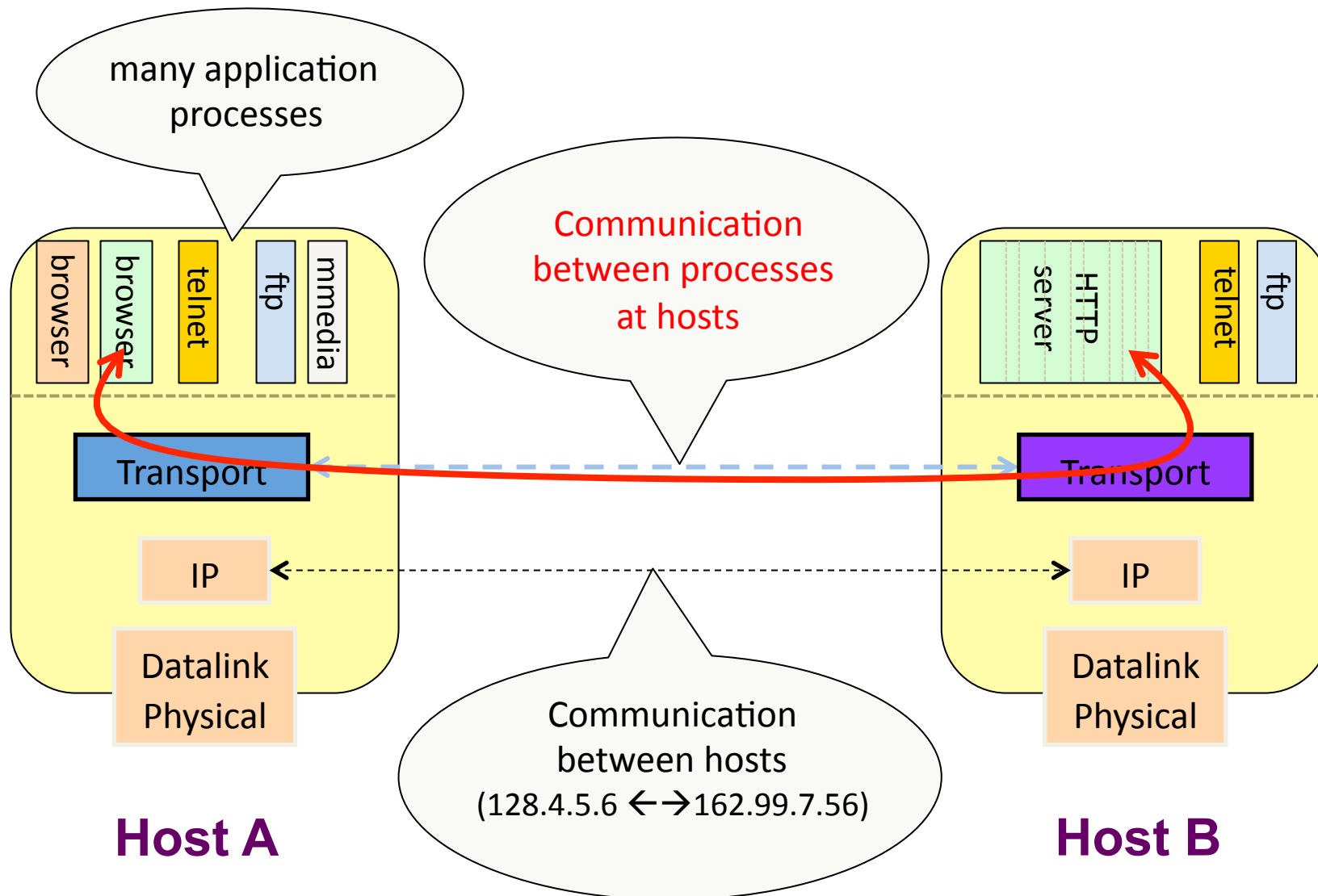

Why a transport layer?

- IP packets are addressed to a host but end-to-end communication is between application processes at hosts
 - Need a way to decide which packets go to which applications (mux/demux)
- IP provides a weak service model (*best-effort*)
 - Packets can be corrupted, delayed, dropped, reordered, duplicated
 - No guidance on how much traffic to send and when
 - Dealing with this is tedious for application developers

Role of the Transport Layer

- Communication between application processes
 - Multiplexing between application processes
 - Implemented using *ports*

Role of the Transport Layer

- Communication between application processes
- Provide common end-to-end services for app layer [optional]
 - Reliable, in-order data delivery
 - Paced data delivery: flow and congestion-control
 - too fast may overwhelm the network
 - too slow is not efficient

Role of the Transport Layer

- Communication between processes
- Provide common end-to-end services for app layer [optional]
- TCP and UDP are the common transport protocols
 - also SCTP, MTCP, SST, RDP, DCCP, ...

Role of the Transport Layer

- Communication between processes
- Provide common end-to-end services for app layer [optional]
- TCP and UDP are the common transport protocols
- **UDP is a minimalist, no-frills transport protocol**
 - only provides mux/demux capabilities

Role of the Transport Layer

- Communication between processes
- Provide common end-to-end services for app layer [optional]
- TCP and UDP are the common transport protocols
- UDP is a minimalist, no-frills transport protocol
- TCP is the *totus porcus* protocol
 - offers apps a reliable, in-order, byte-stream abstraction
 - with congestion control
 - but **no** performance (delay, bandwidth, ...) guarantees

Role of the Transport Layer

- Communication between processes
 - mux/demux from and to application processes
 - implemented using ports

Context: Applications and Sockets

- Socket: software abstraction by which an application process exchanges network messages with the (transport layer in the) operating system
 - `socketID = socket(..., socket.TYPE)`
 - `socketID.sendto(message, ...)`
 - `socketID.recvfrom(...)`
- Two important types of sockets
 - UDP socket: TYPE is `SOCK_DGRAM`
 - TCP socket: TYPE is `SOCK_STREAM`

Ports

- Problem: deciding which app (socket) gets which packets
- Solution: *port* as a transport layer identifier
 - 16 bit identifier
 - OS stores mapping between sockets and *ports*
 - a packet carries a source and destination port number in its transport layer header
- For UDP ports (SOCK_DGRAM)
 - OS stores (local port, local IP address) \leftrightarrow socket
- For TCP ports (SOCK_STREAM)
 - OS stores (local port, local IP, remote port, remote IP) \leftrightarrow socket

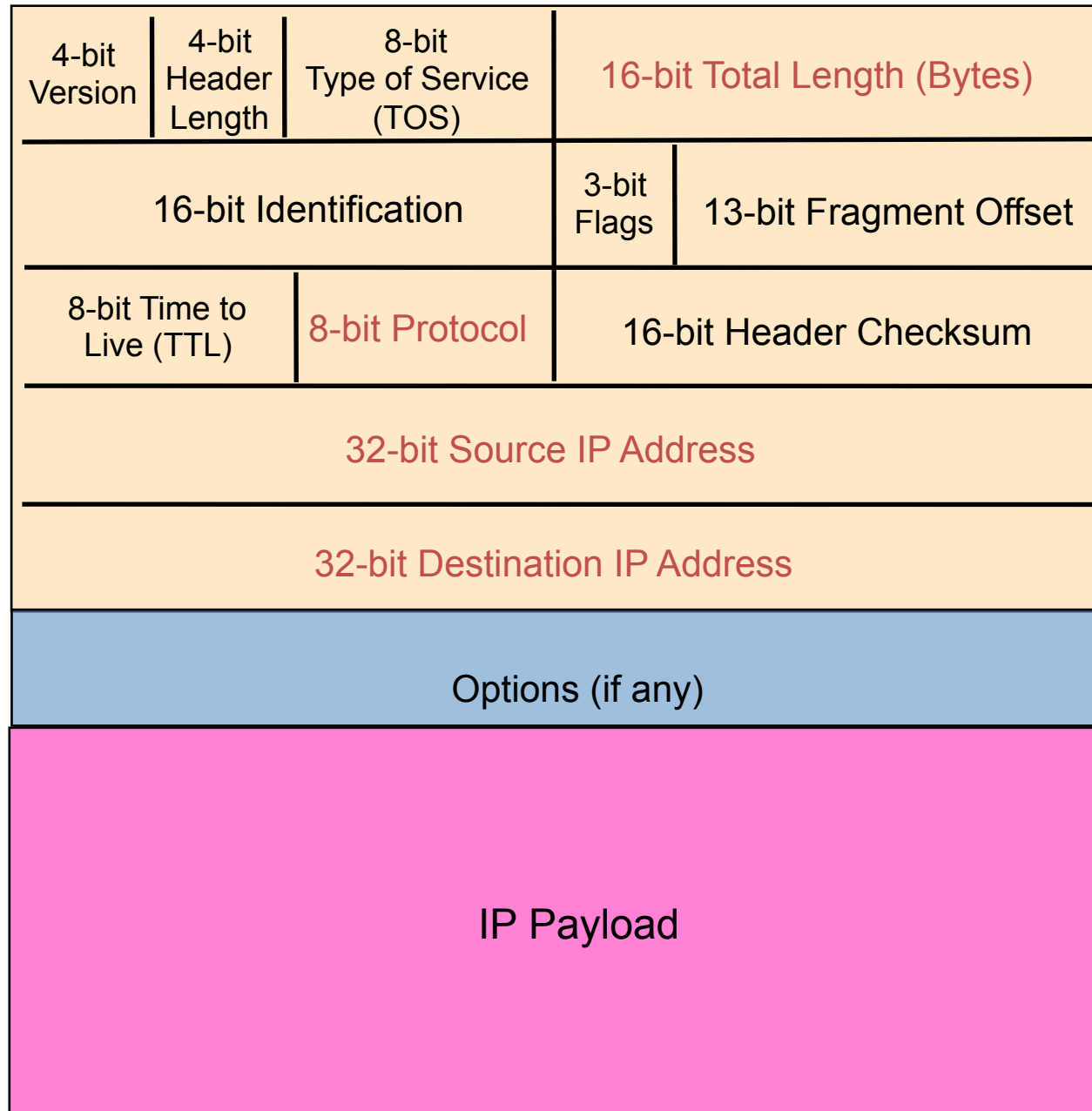

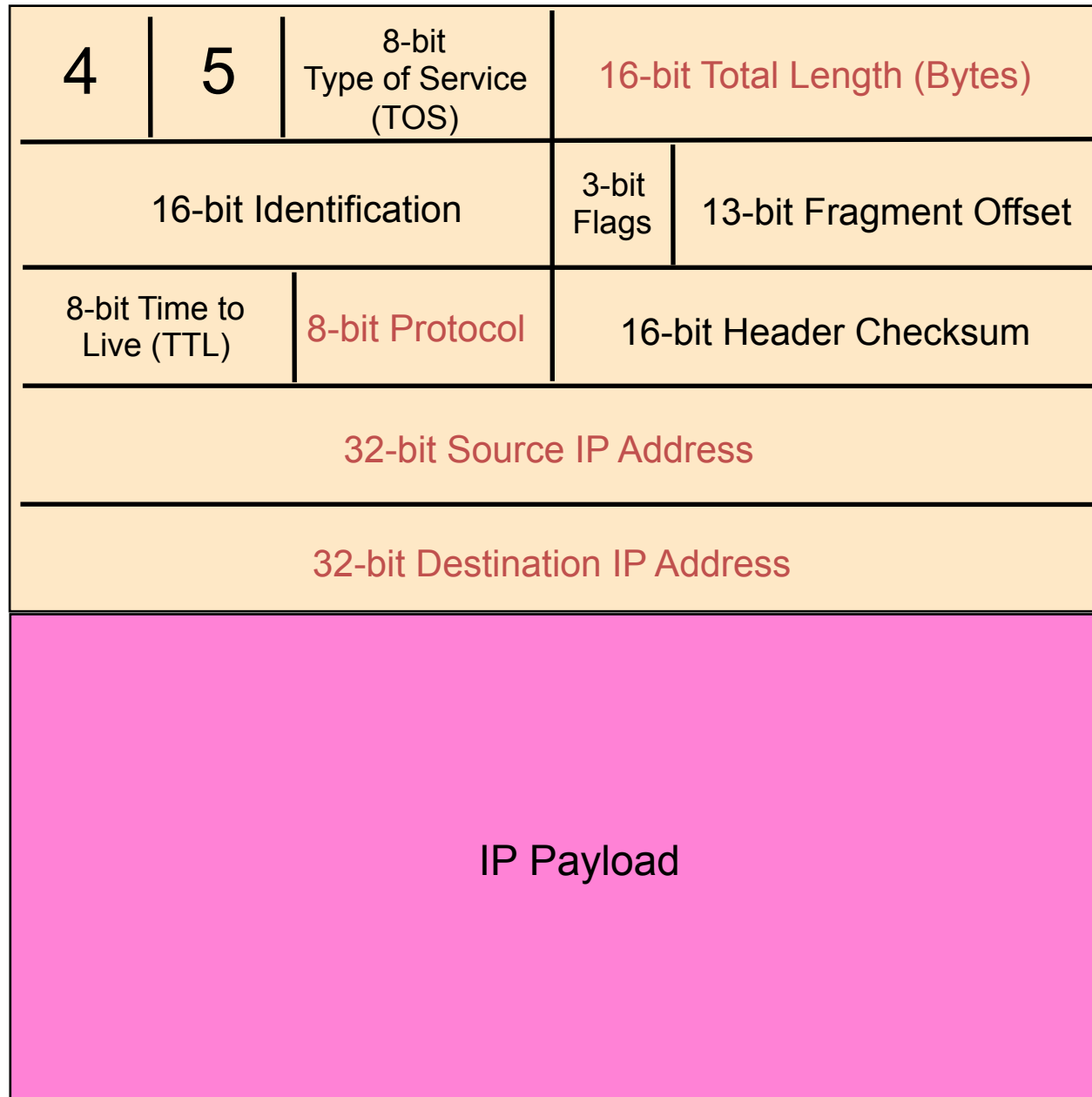

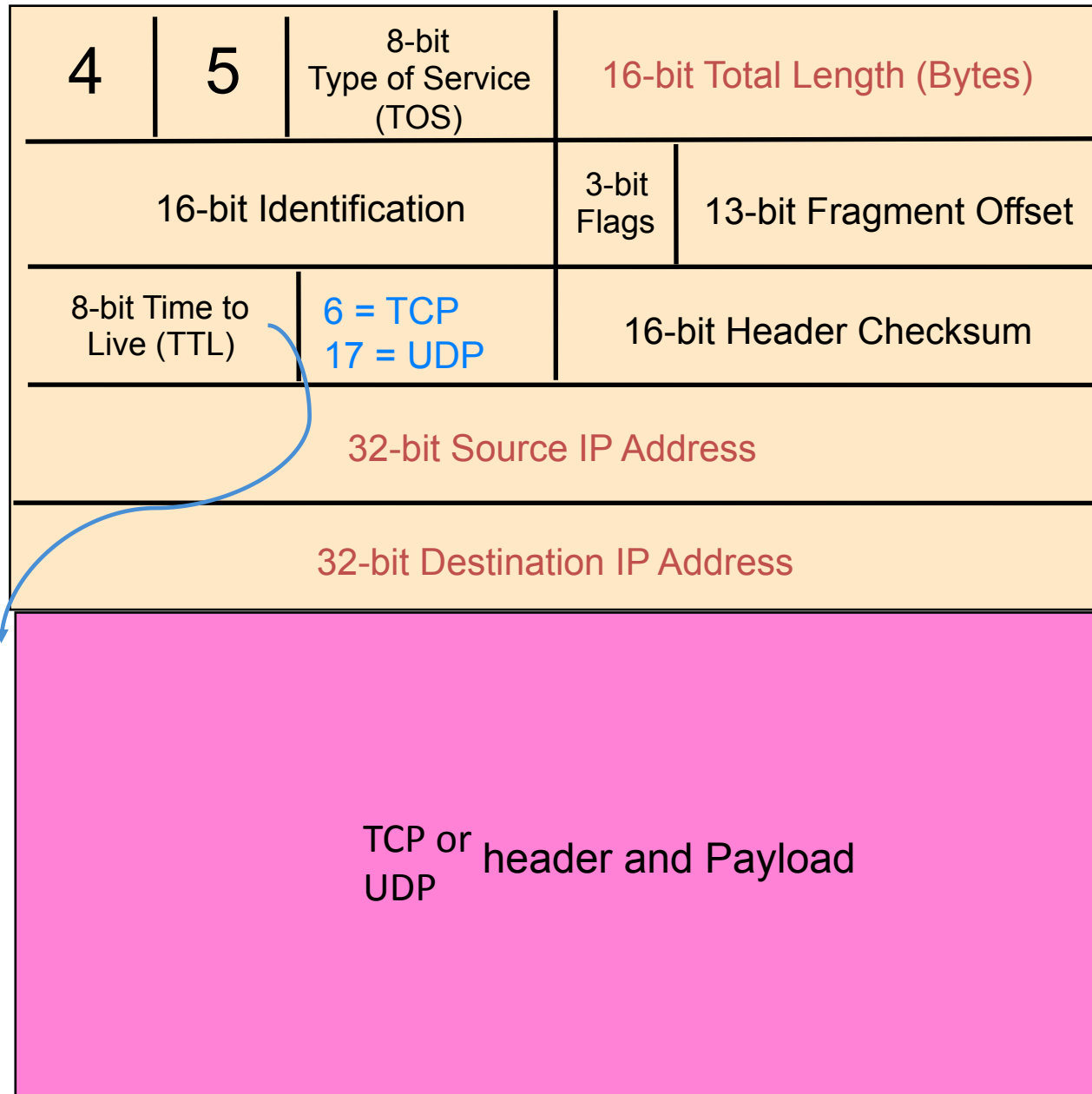

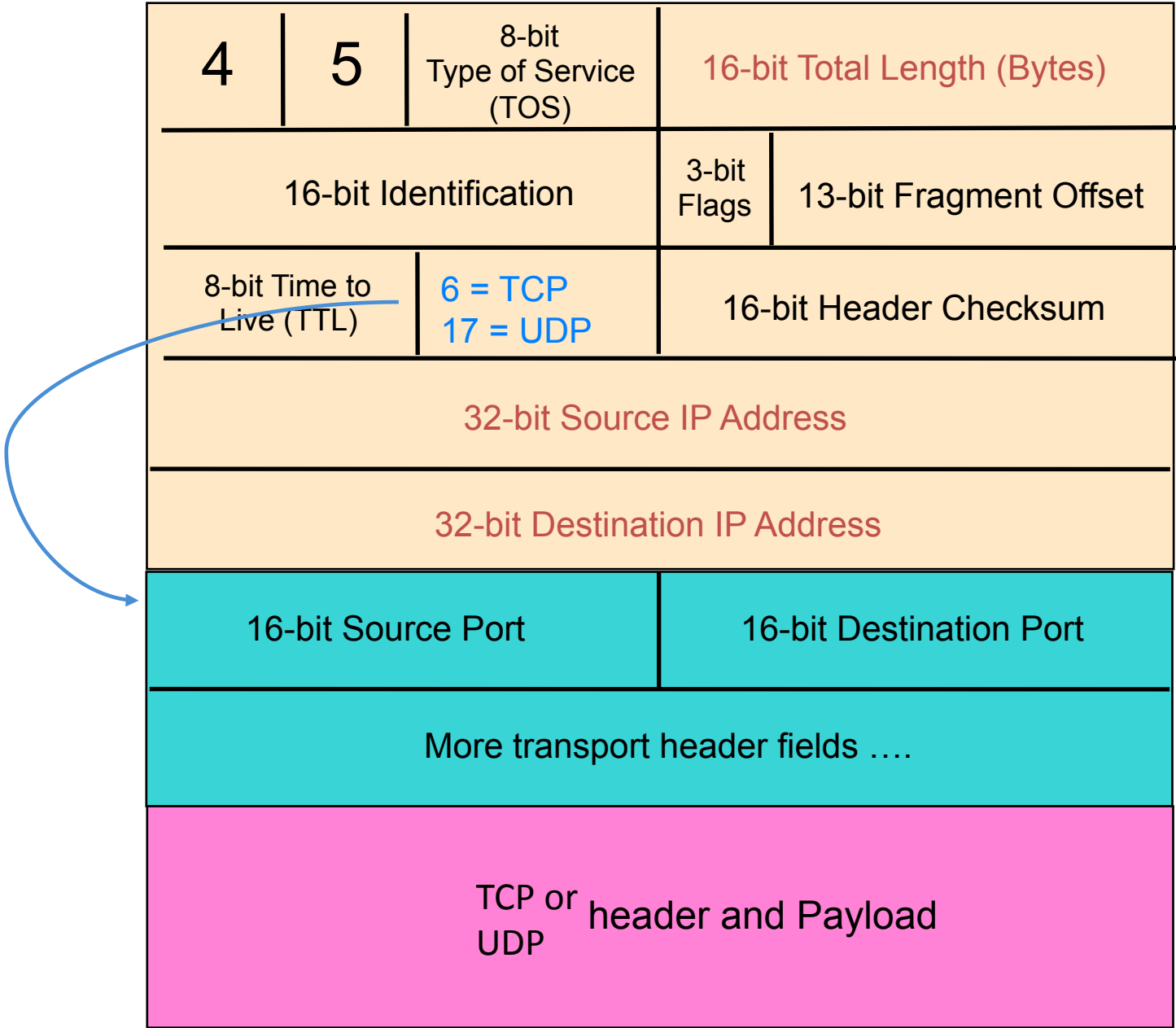

Recap: Multiplexing and Demultiplexing

- Host receives IP packets
 - Each IP header has source and destination **IP address**
 - Each Transport Layer header has source and destination **port** number
- Host uses IP addresses and port numbers to direct the message to appropriate **socket**

More on Ports

- Separate 16-bit port address space for UDP and TCP
- “Well known” ports (0-1023): everyone agrees which services run on these ports
 - e.g., ssh:22, http:80
 - helps client know server’s port
- Ephemeral ports (most 1024-65535): dynamically selected: as the source port for a client process

UDP: User Datagram Protocol

- Lightweight communication between processes
 - Avoid overhead and delays of ordered, reliable delivery
- UDP described in RFC 768 – (1980!)
 - Destination IP address and port to support demultiplexing
 - Optional error checking on the packet contents
 - (checksum field of 0 means “don’t verify checksum”)

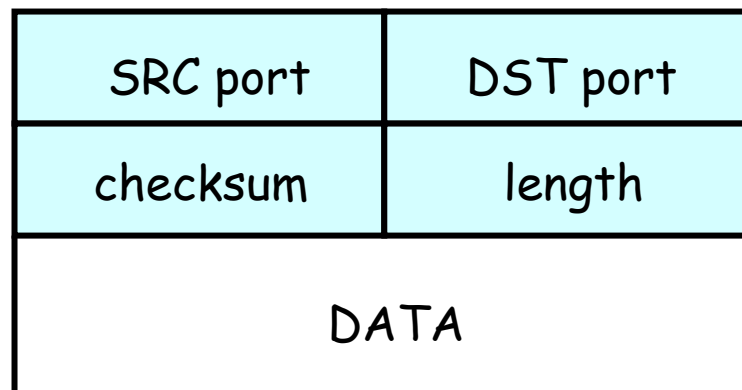

Why a transport layer?

- IP packets are addressed to a host but end-to-end communication is between application processes at hosts
 - Need a way to decide which packets go to which applications (mux/demux)
- IP provides a weak service model (*best-effort*)
 - Packets can be corrupted, delayed, dropped, reordered, duplicated

Principles of Reliable data transfer

- important in app., transport, link layers
- top-10 list of important networking topics!

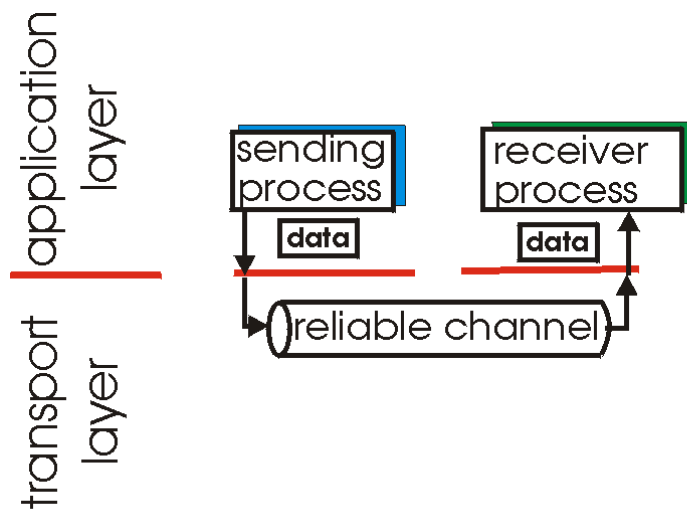

(a) provided service

- In a perfect world, reliable transport is easy

But the Internet default is *best-effort*

- All the bad things best-effort can do
 - a packet is corrupted (bit errors)
 - a packet is lost
 - a packet is delayed (*why?*)
 - packets are reordered (*why?*)
 - a packet is duplicated (*why?*)

Principles of Reliable data transfer

- important in app., transport, link layers
- top-10 list of important networking topics!

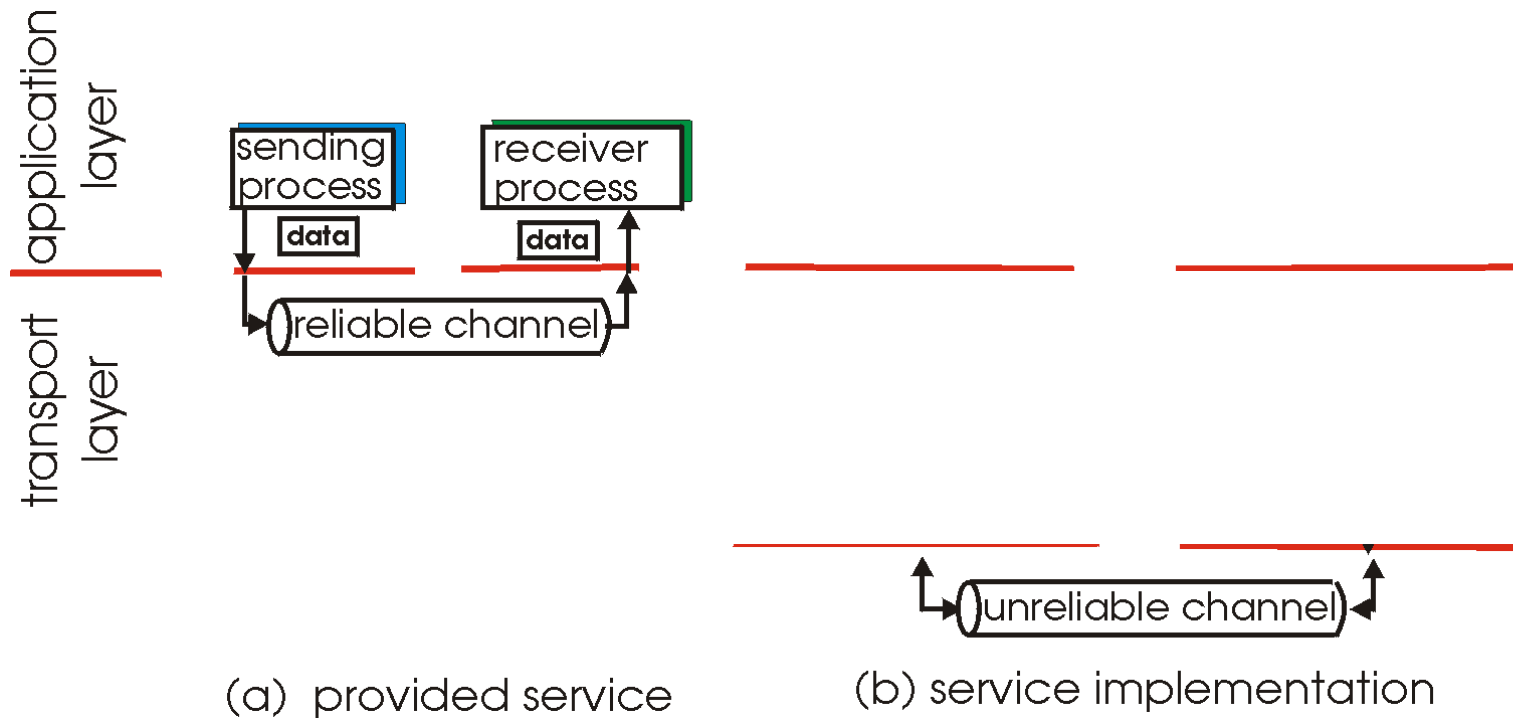

- characteristics of unreliable channel will determine complexity of reliable data transfer protocol (rdt)

Principles of Reliable data transfer

- important in app., transport, link layers
- top-10 list of important networking topics!

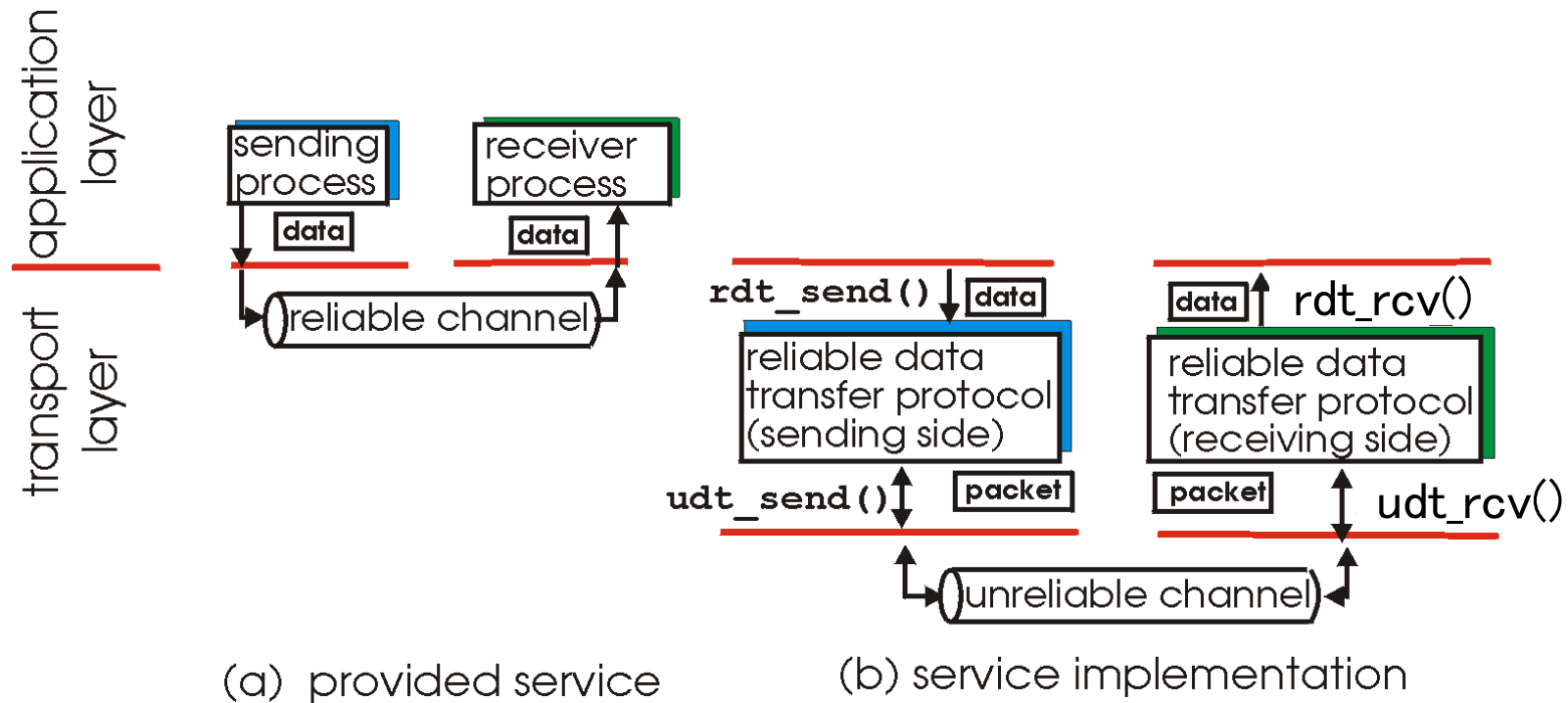

- characteristics of unreliable channel will determine complexity of reliable data transfer protocol (rdt)

Reliable data transfer: getting started

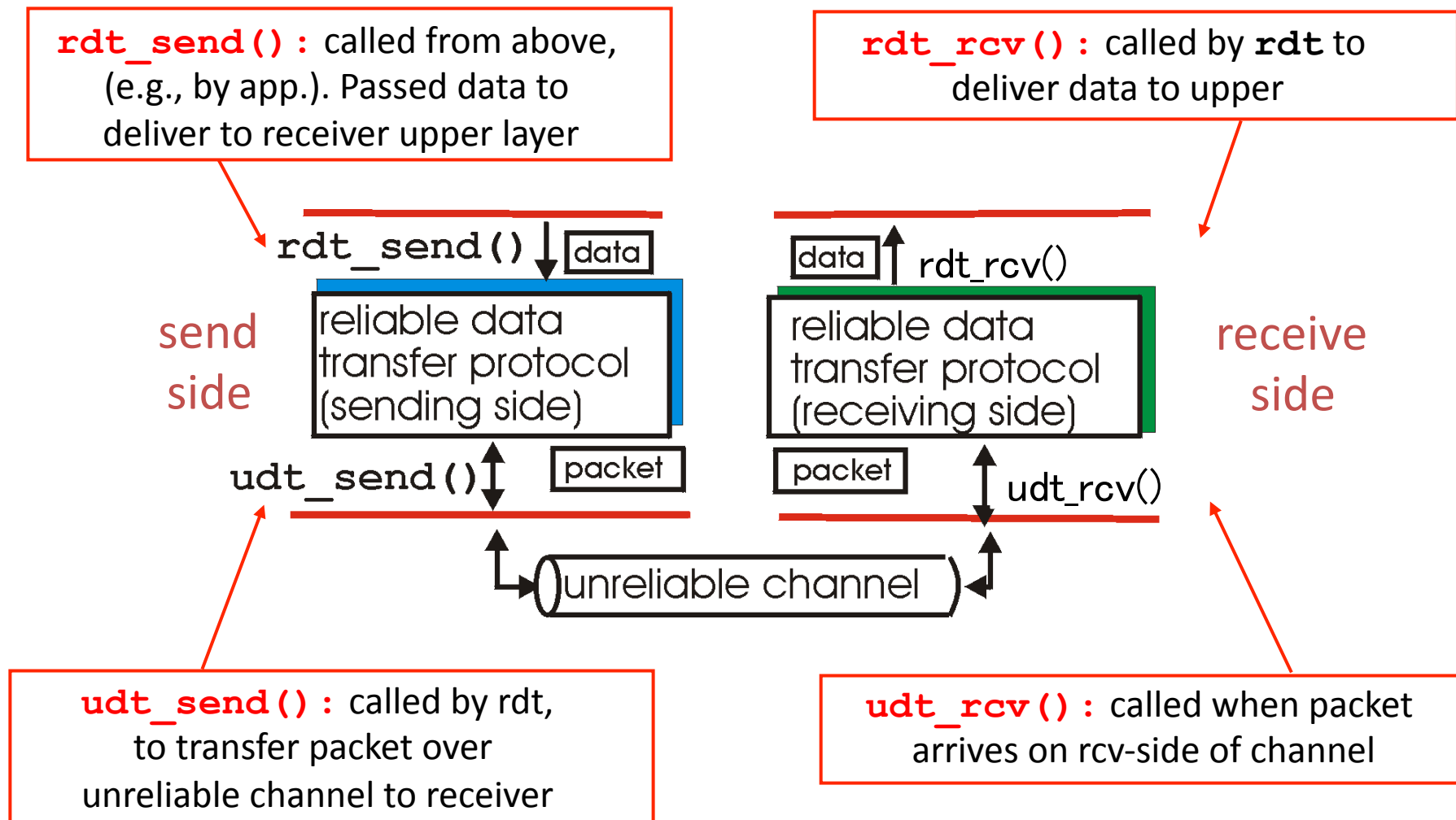

Reliable data transfer: getting started

We' ll:

- incrementally develop sender, receiver sides of reliable data transfer protocol (rdt)
- consider only unidirectional data transfer
 - but control info will flow on both directions!
- use finite state machines (FSM) to specify sender, receiver

state: when in this “state”
next state uniquely
determined by next
event

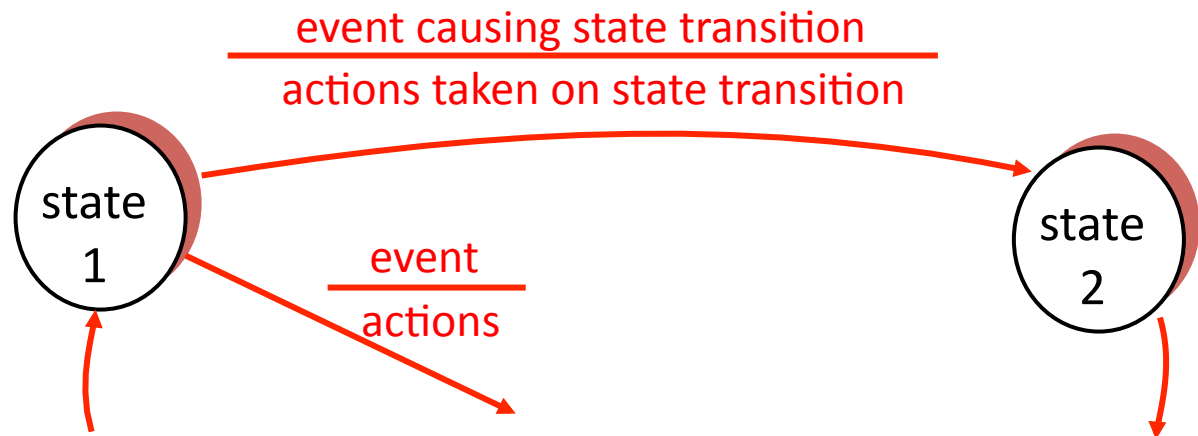

KR state machines – a note.

Beware

Kurose and Ross has a confusing/confused attitude to state-machines.

I've attempted to normalise the representation.

UPSHOT: these slides have differing information to the KR book (from which the RDT example is taken.)

in KR “actions taken” appear wide-ranging, my interpretation is more specific/relevant.

state: when in this “state”
next state uniquely
determined by next
event

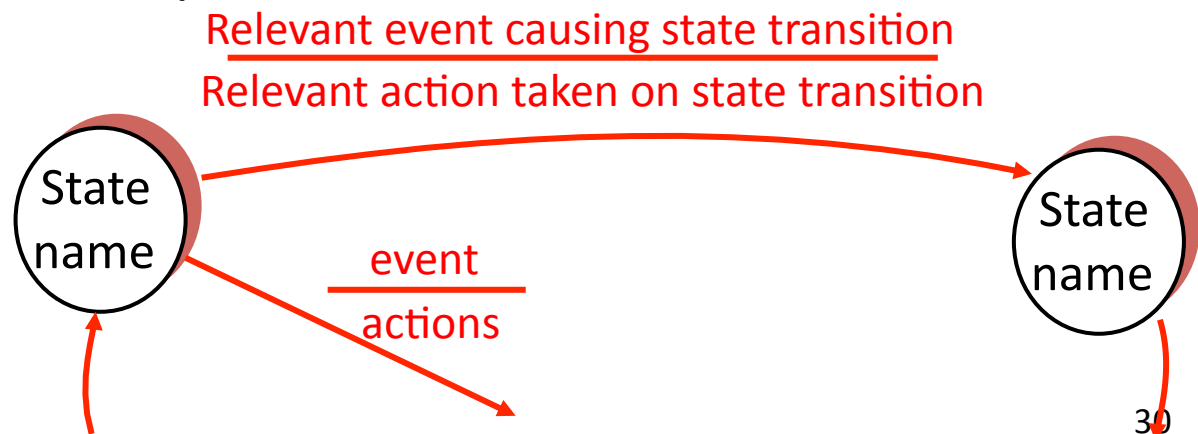

Rdt1.0: reliable transfer over a reliable channel

- underlying channel perfectly reliable
 - no bit errors
 - no loss of packets
- separate FSMs for sender, receiver:
 - sender sends data into underlying channel
 - receiver read data from underlying channel

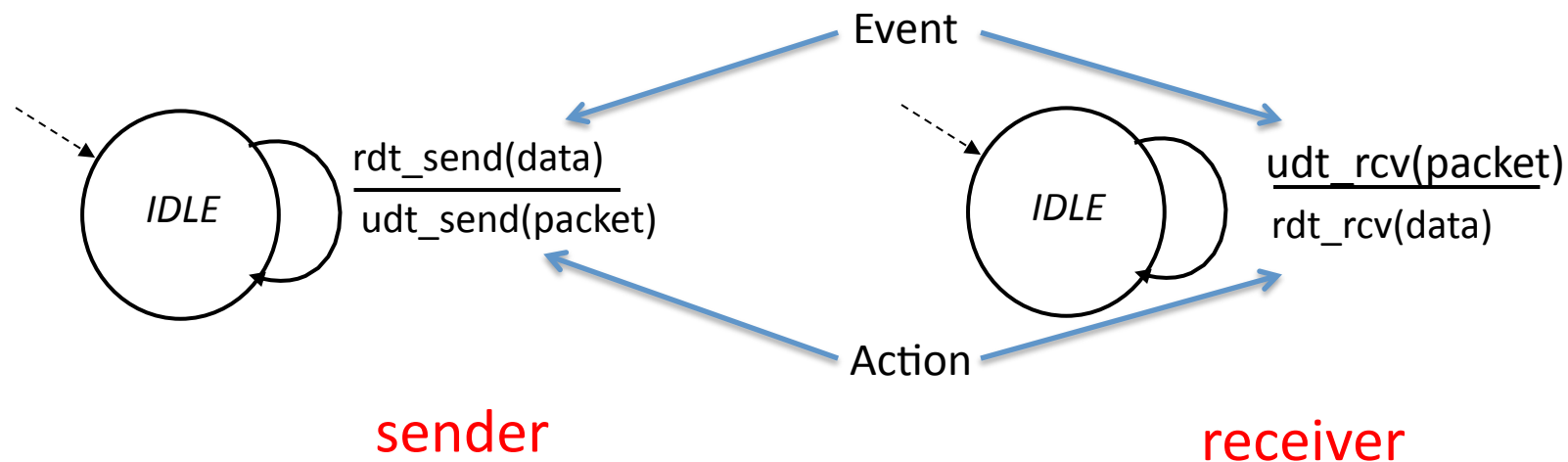

Rdt2.0: channel with bit errors

- underlying channel may flip bits in packet
 - checksum to detect bit errors
- *the* question: how to recover from errors:
 - *acknowledgements (ACKs)*: receiver explicitly tells sender that packet received is OK
 - *negative acknowledgements (NAKs)*: receiver explicitly tells sender that packet had errors
 - sender retransmits packet on receipt of NAK
- new mechanisms in **rdt2.0** (beyond **rdt1.0**):
 - error detection
 - receiver feedback: control msgs (ACK,NAK) receiver->sender

Dealing with Packet Corruption

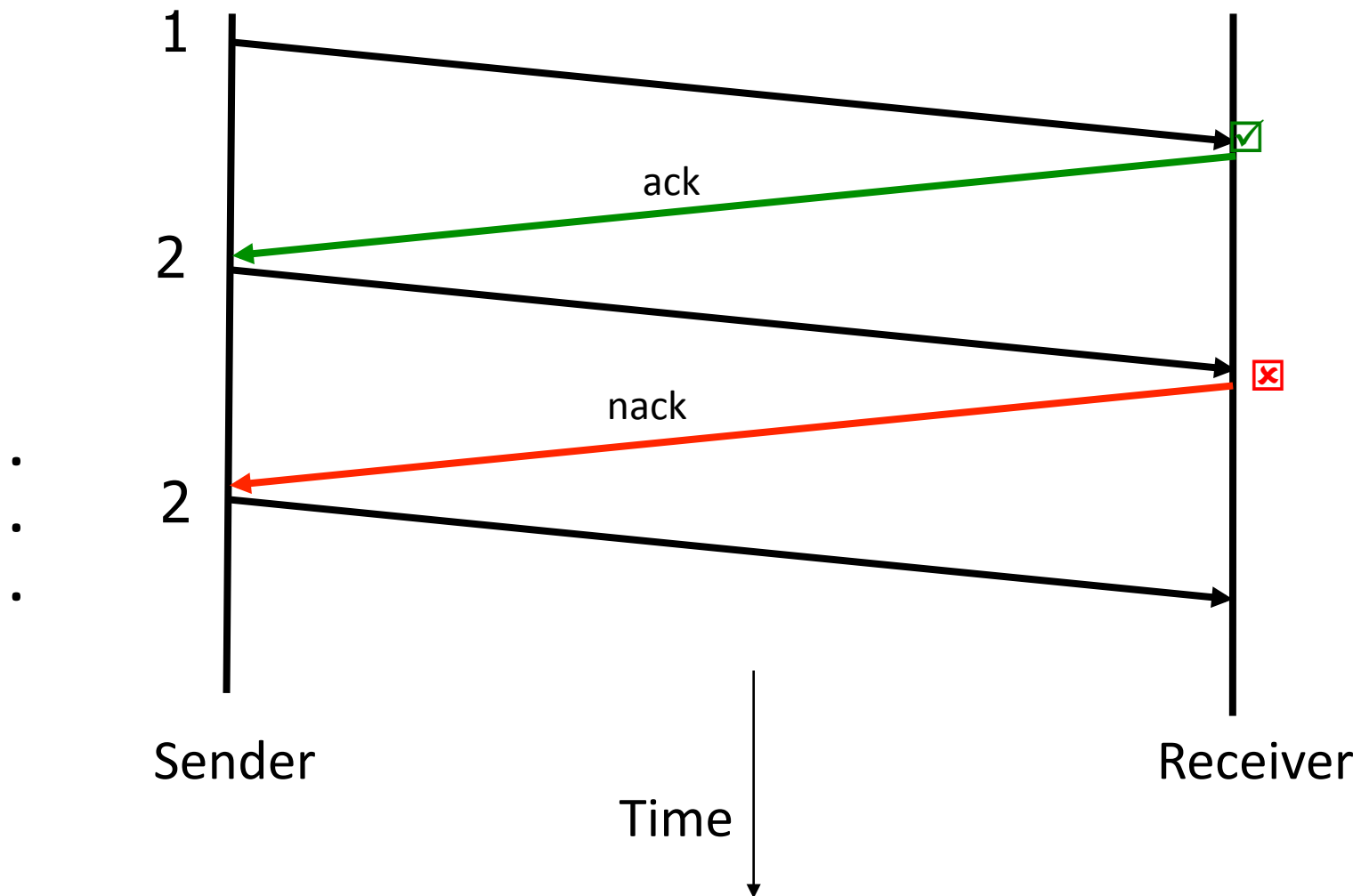

rdt2.0: FSM specification

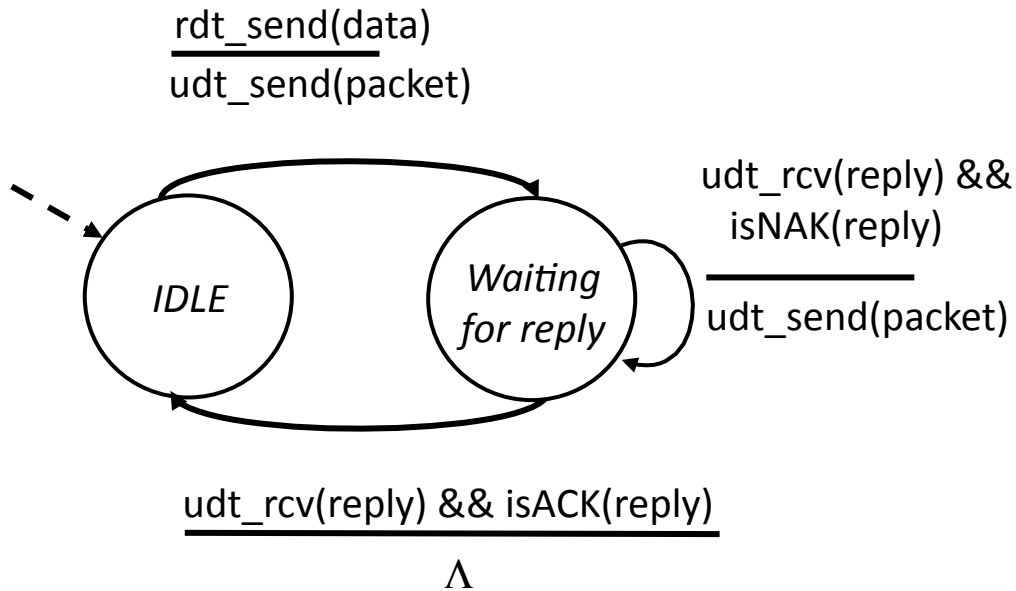

sender

Note: the sender holds a copy of the packet being sent until the delivery is acknowledged.

receiver

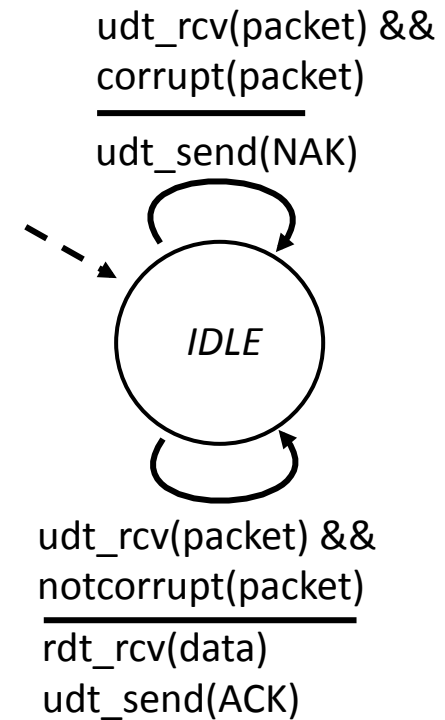

rdt2.0: operation with no errors

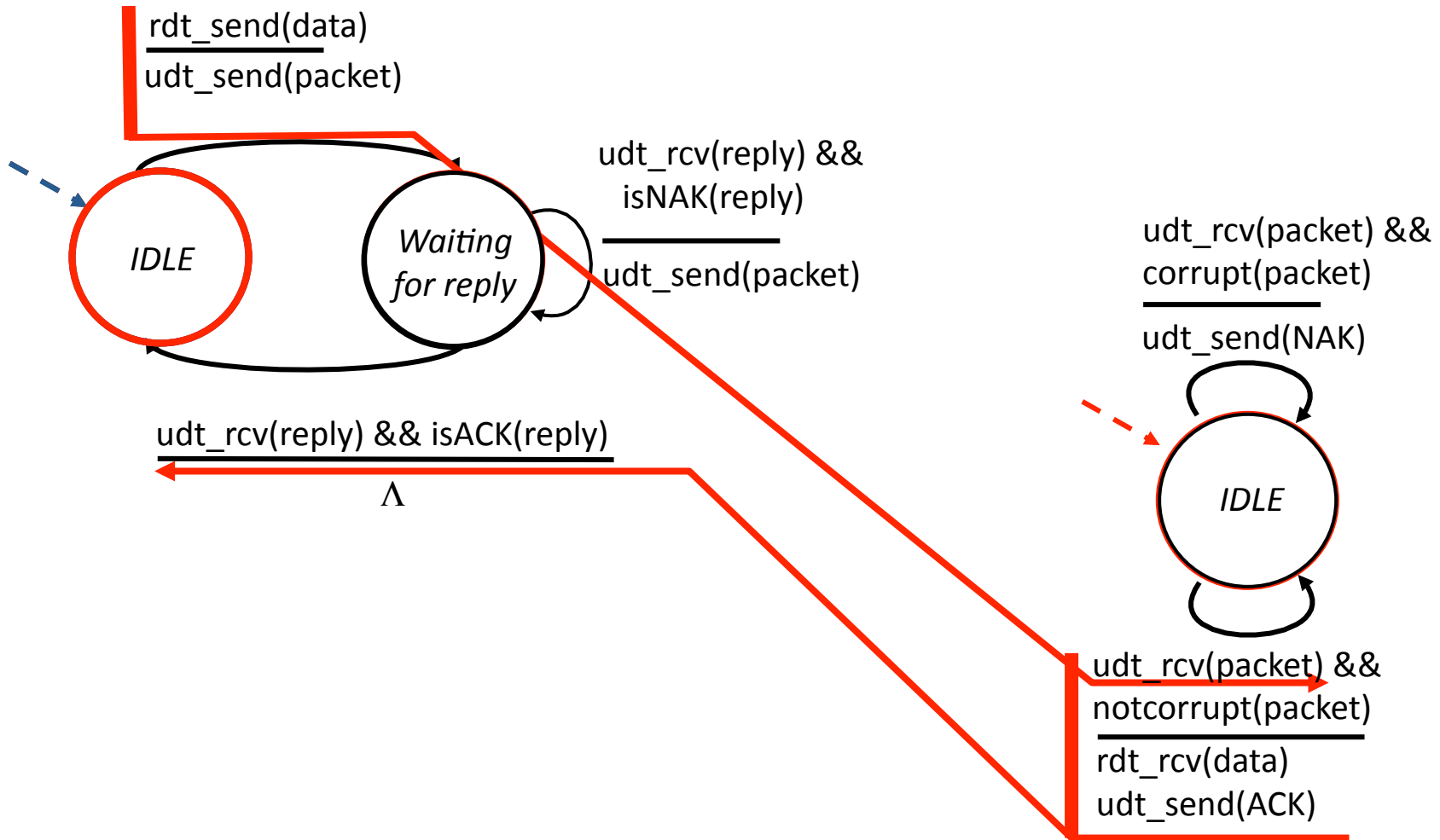

rdt2.0: error scenario

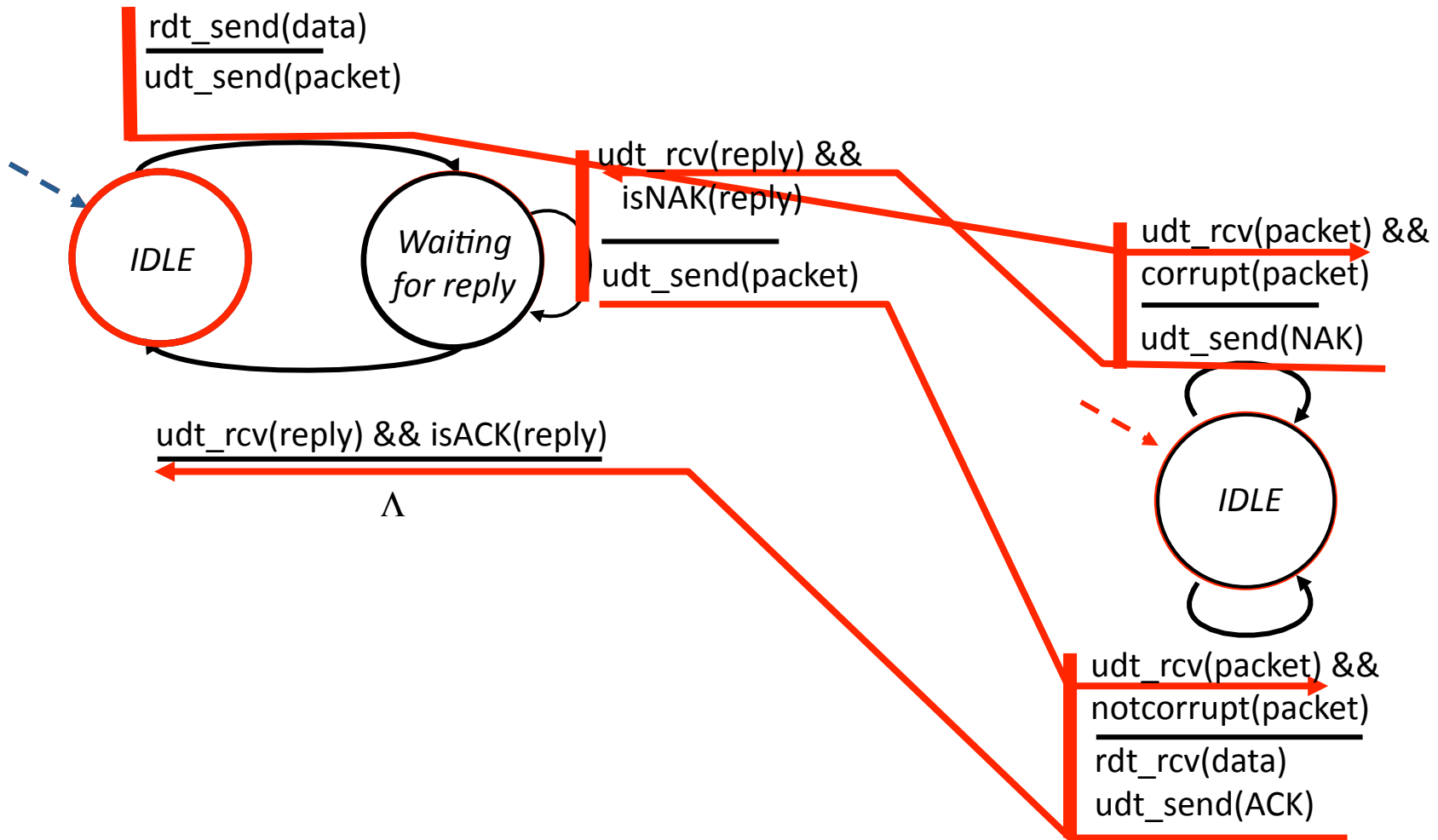

rdt2.0 has a fatal flaw!

What happens if ACK/NAK corrupted?

- sender doesn't know what happened at receiver!
- can't just retransmit: possible duplicate

Handling duplicates:

- sender retransmits current packet if ACK/NAK garbled
- sender adds *sequence number* to each packet
- receiver discards (doesn't deliver) duplicate packet

stop and wait

Sender sends one packet, then waits for receiver response

Dealing with Packet Corruption

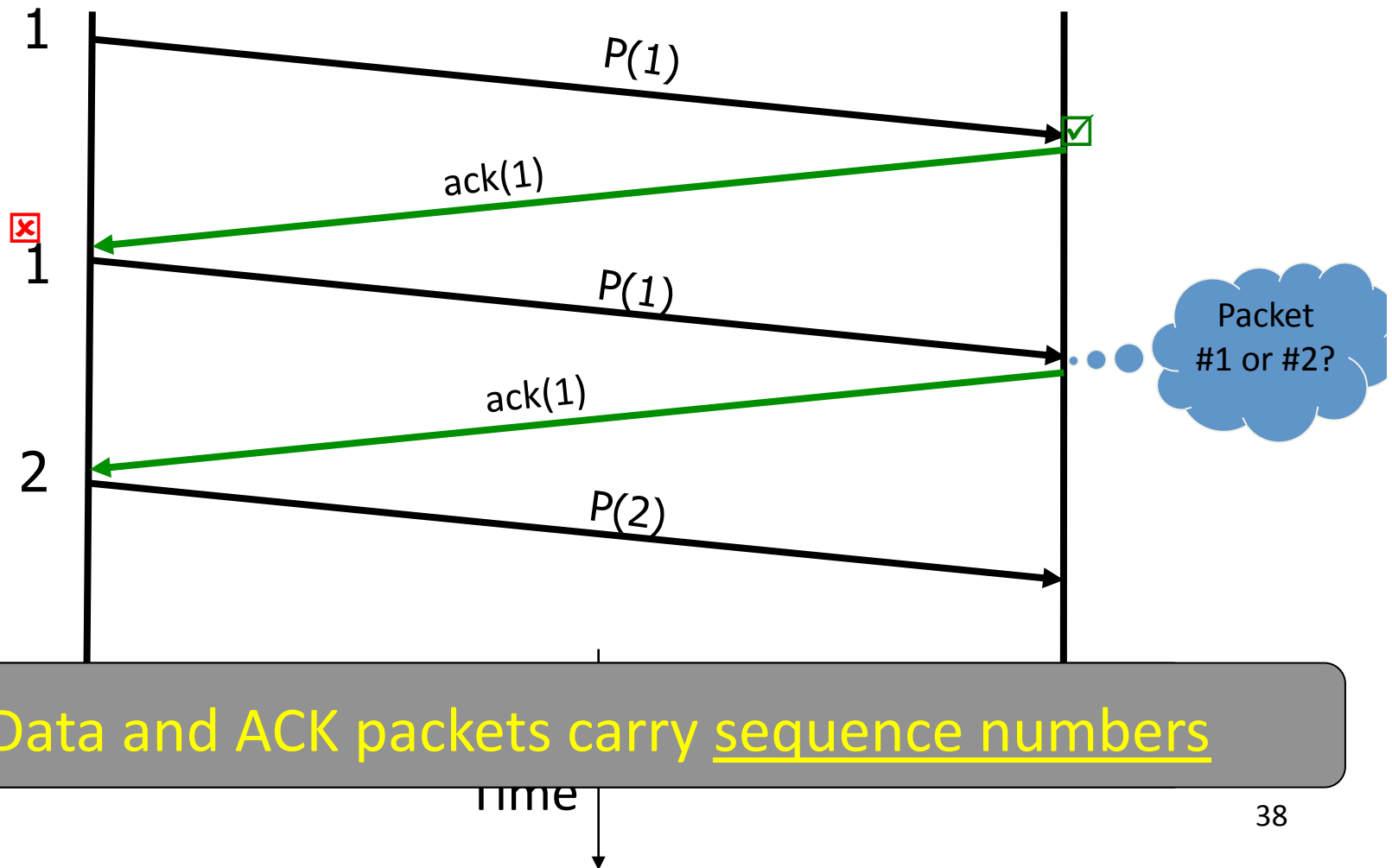

rdt2.1: sender, handles garbled ACK/NAKs

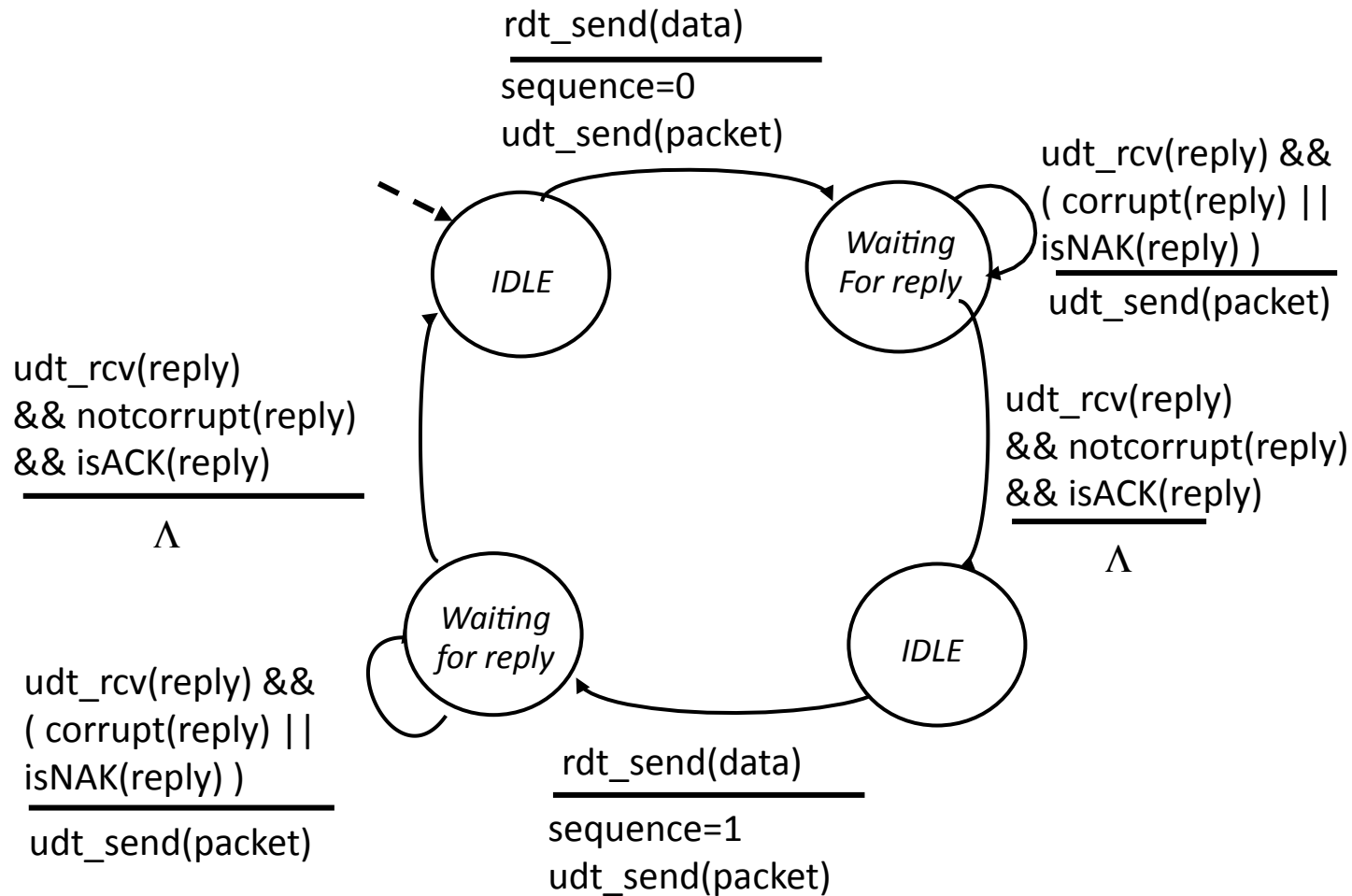

rdt2.1: receiver, handles garbled ACK/NAKs

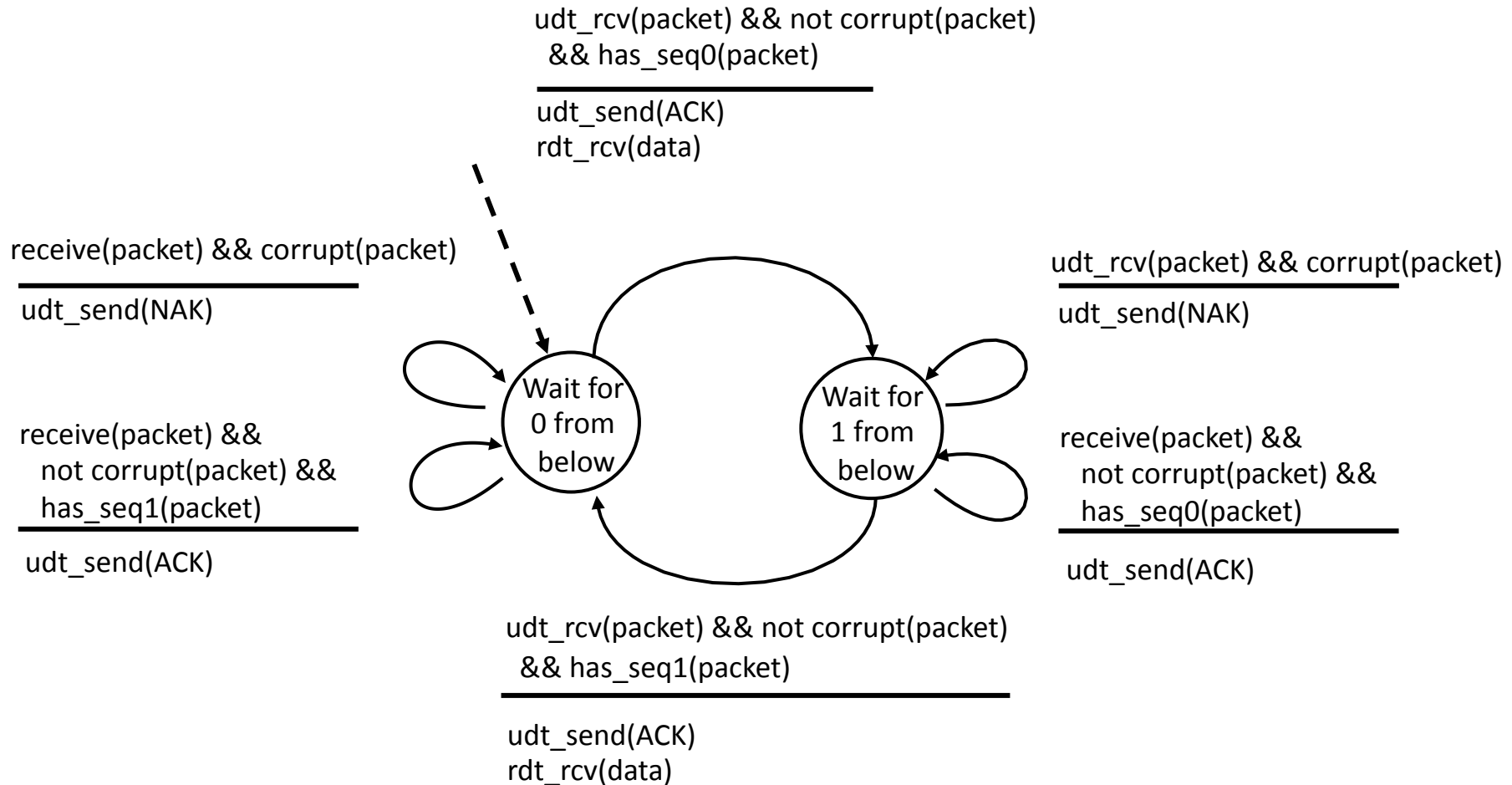

rdt2.1: discussion

Sender:

- seq # added to pkt
- two seq. #'s (0,1) will suffice. Why?
- must check if received ACK/NAK corrupted
- twice as many states
 - state must “remember” whether “current” pkt has a 0 or 1 sequence number

Receiver:

- must check if received packet is duplicate
 - state indicates whether 0 or 1 is expected pkt seq #
- note: receiver can *not* know if its last ACK/NAK received OK at sender

rdt2.2: a NAK-free protocol

- same functionality as rdt2.1, using ACKs only
- instead of NAK, receiver sends ACK for last pkt received OK
 - receiver must *explicitly* include seq # of pkt being ACKed
- duplicate ACK at sender results in same action as NAK:
retransmit current pkt

rdt2.2: sender, receiver fragments

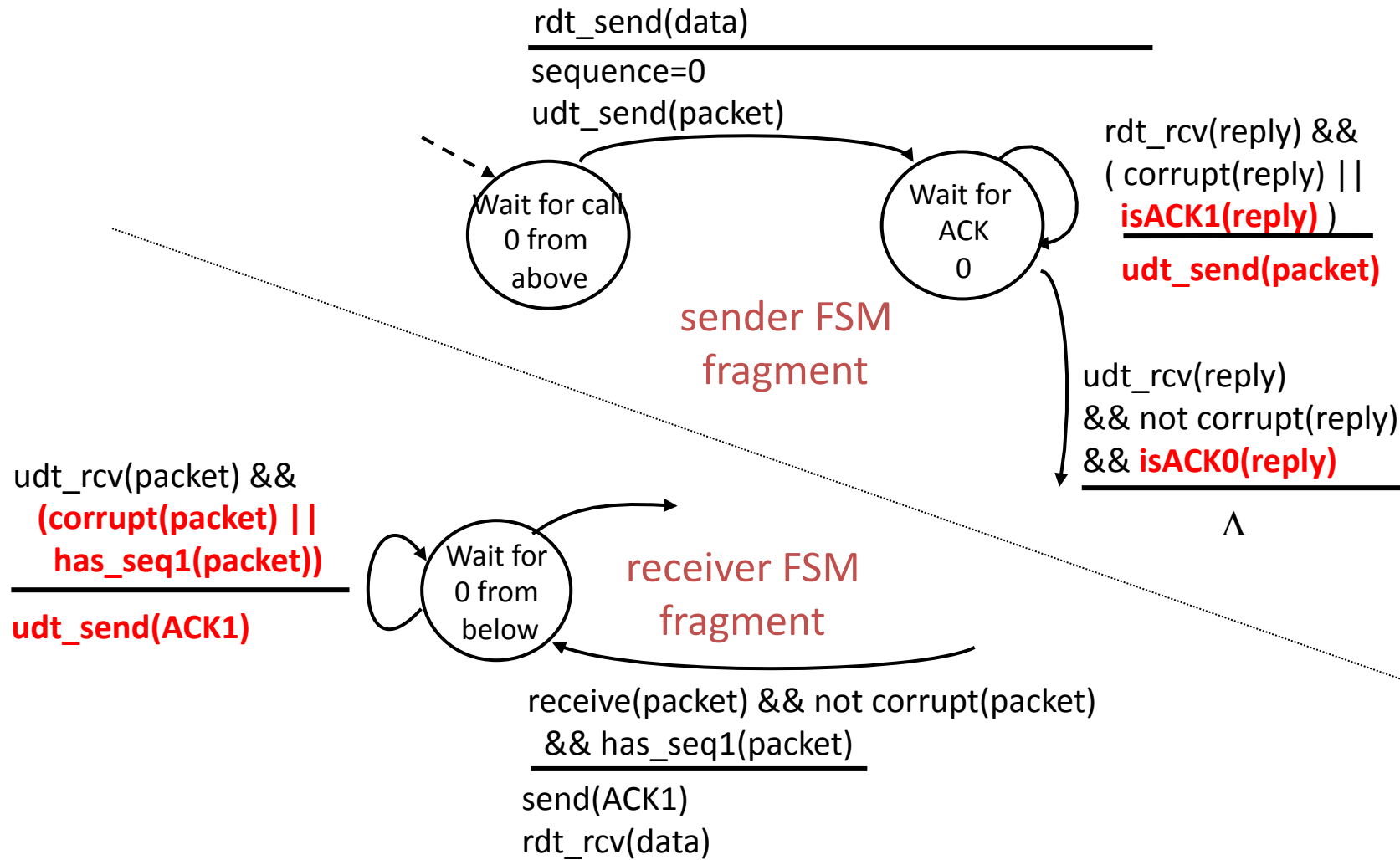

rdt3.0: channels with errors *and* loss

New assumption: underlying channel can also lose packets (data or ACKs)

- checksum, seq. #, ACKs, retransmissions will be of help, but not enough

Approach: sender waits “reasonable” amount of time for ACK

- retransmits if no ACK received in this time
- if pkt (or ACK) just delayed (not lost):
 - retransmission will be duplicate, but use of seq. #'s already handles this
 - receiver must specify seq # of pkt being ACKed
- requires countdown timer

rdt3.0 sender

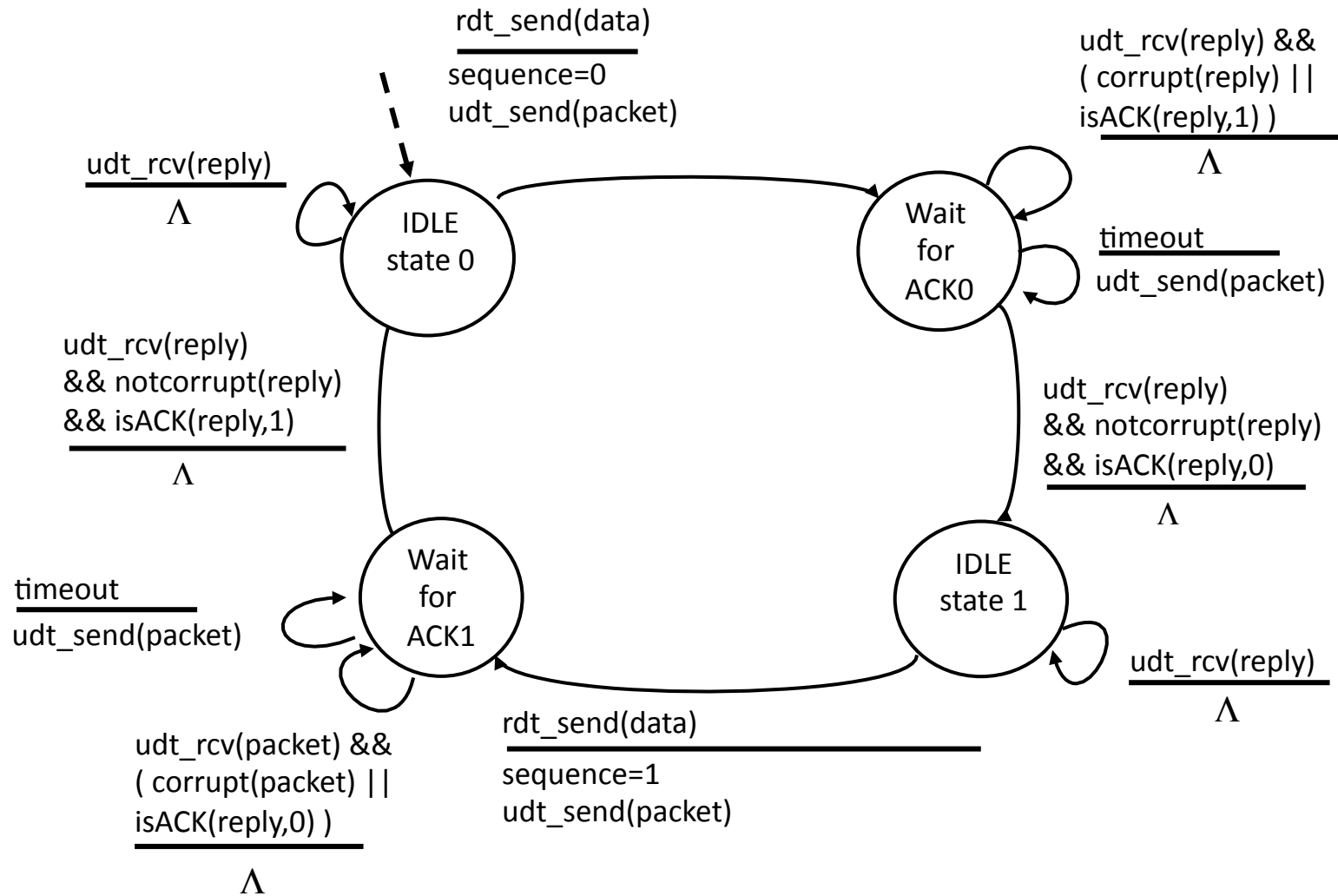

Dealing with Packet Loss

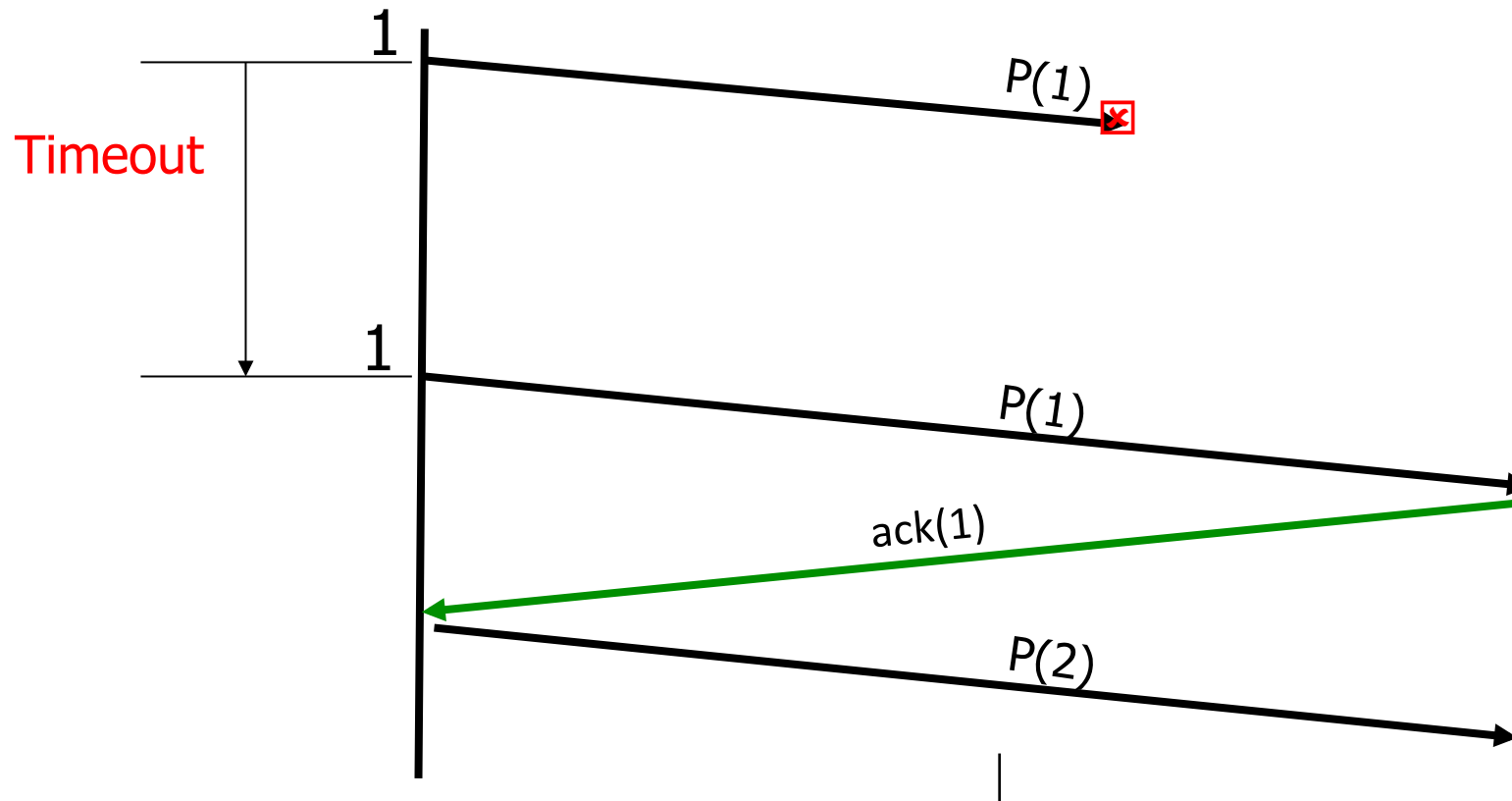

Timer-driven loss detection
Set timer when packet is sent; retransmit on timeout

Dealing with Packet Loss

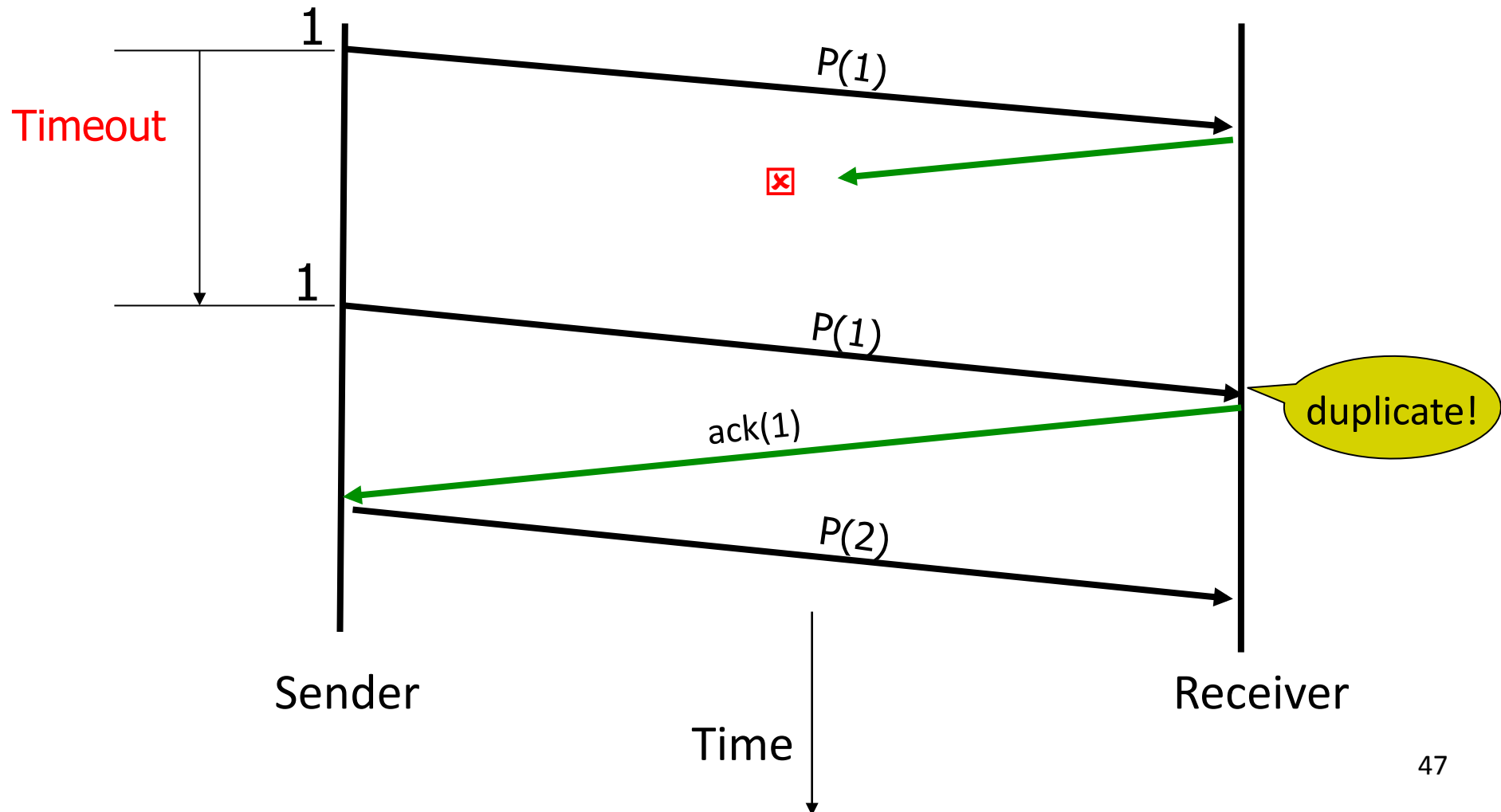

Dealing with Packet Loss

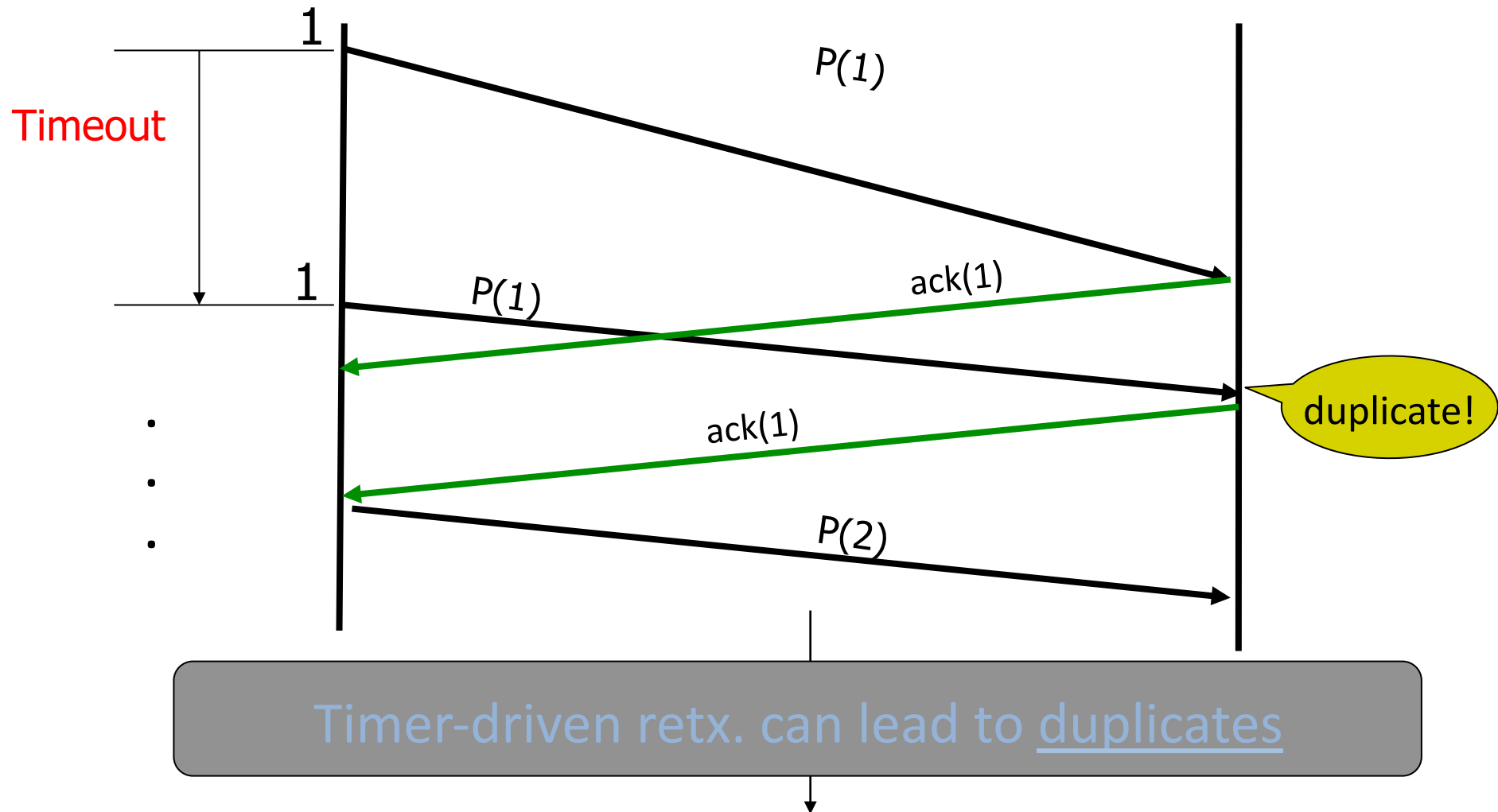

Performance of rdt3.0

- rdt3.0 works, but performance stinks
- ex: 1 Gbps link, 15 ms prop. delay, 8000 bit packet:

$$d_{trans} = \frac{L}{R} = \frac{8000\text{bits}}{10^9\text{bps}} = 8\text{microseconds}$$

- U_{sender} : **utilization** – fraction of time sender busy sending

$$U_{\text{sender}} = \frac{L / R}{RTT + L / R} = \frac{.008}{30.008} = 0.00027$$

- 1KB pkt every 30 msec -> 33kB/sec throughput over 1 Gbps link
- network protocol limits use of physical resources!

rdt3.0: stop-and-wait operation

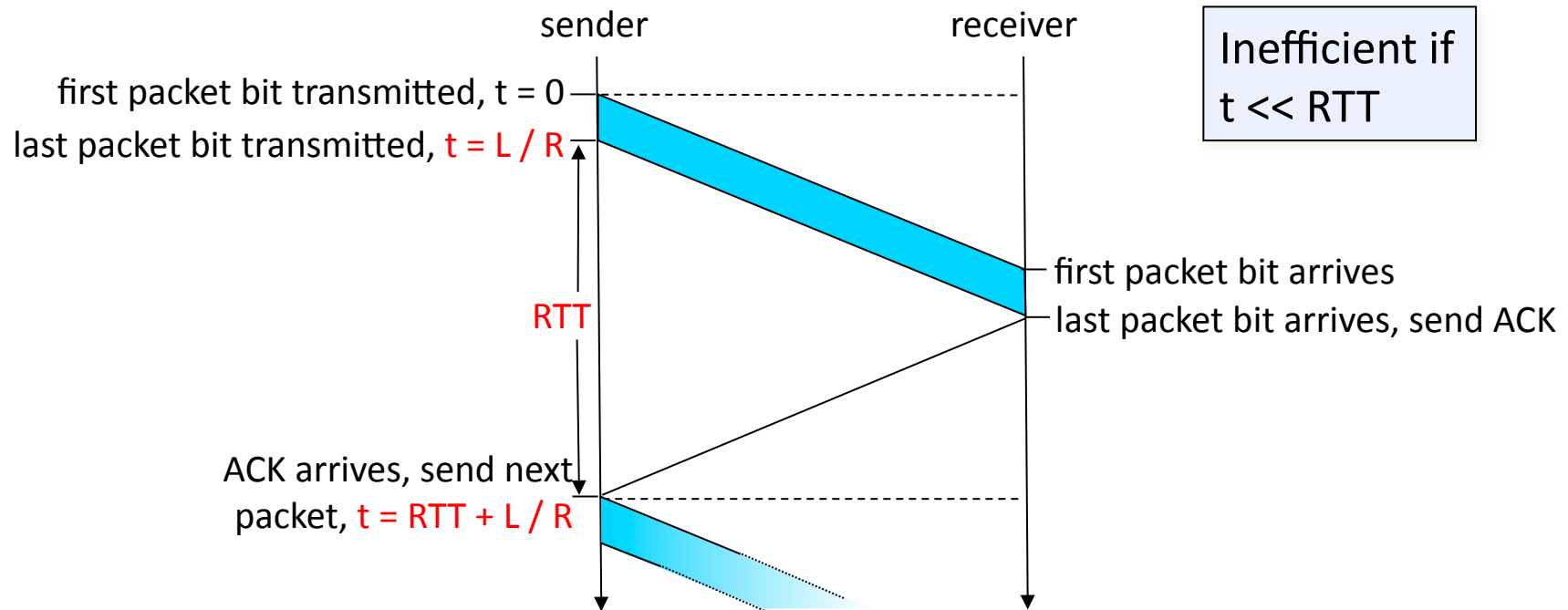

$$U_{\text{sender}} = \frac{L/R}{RTT + L/R} = \frac{.008}{30.008} = 0.00027$$

Pipelined (Packet-Window) protocols

Pipelining: sender allows multiple, “in-flight”, yet-to-be-acknowledged pkts

- range of sequence numbers must be increased
- buffering at sender and/or receiver

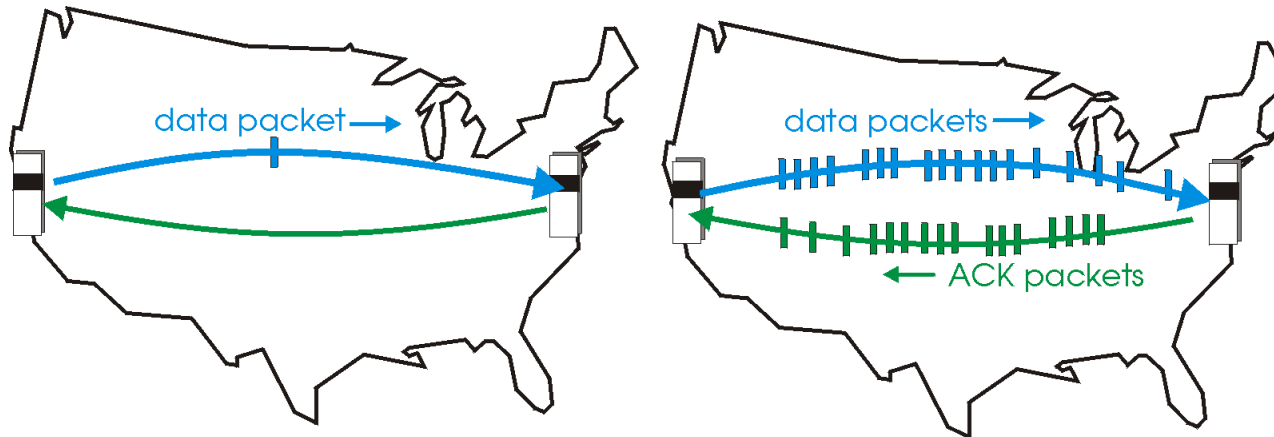

(a) a stop-and-wait protocol in operation

(b) a pipelined protocol in operation

A Sliding Packet Window

- **window** = set of adjacent sequence numbers
 - The size of the set is the **window size**; assume window size is n
- General idea: send up to n packets at a time
 - Sender can send packets in its window
 - Receiver can accept packets in its window
 - Window of acceptable packets “slides” on successful reception/acknowledgement

A Sliding Packet Window

- Let A be the **last ack'd packet of sender without gap**;
then window of sender = {A+1, A+2, ..., A+n}

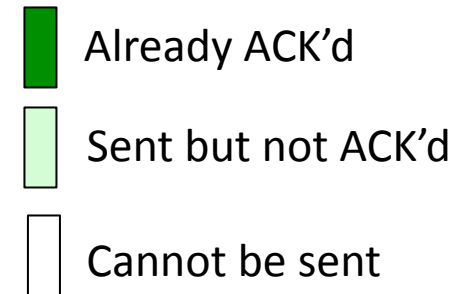
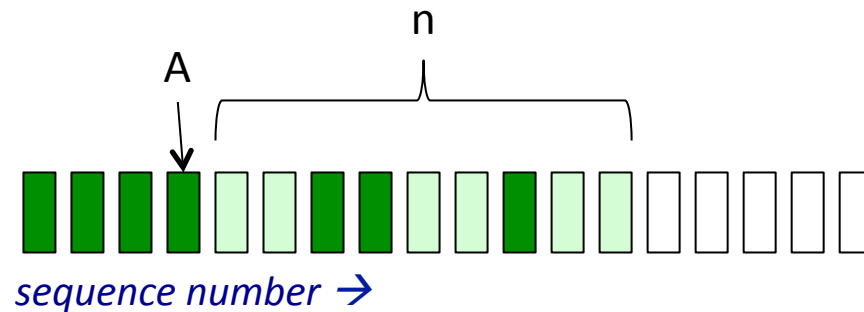

- Let B be the **last received packet without gap** by receiver,
then window of receiver = {B+1, ..., B+n}

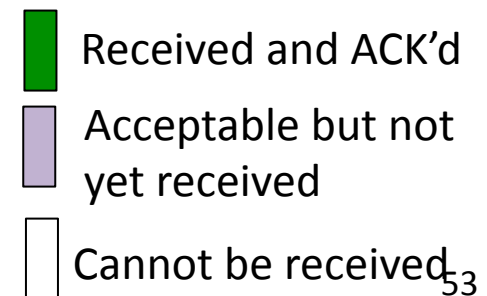
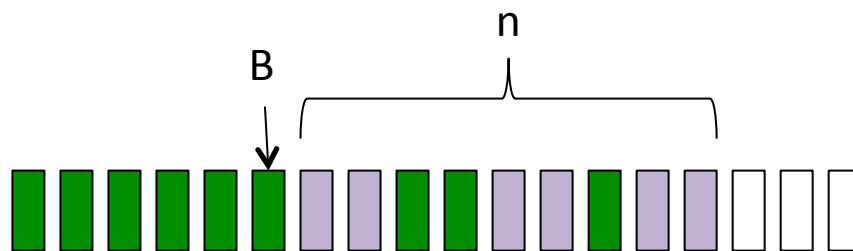

Acknowledgements w/ Sliding Window

- Two common options
 - cumulative ACKs: ACK carries next in-order sequence number that the receiver expects

Cumulative Acknowledgements (1)

- At receiver

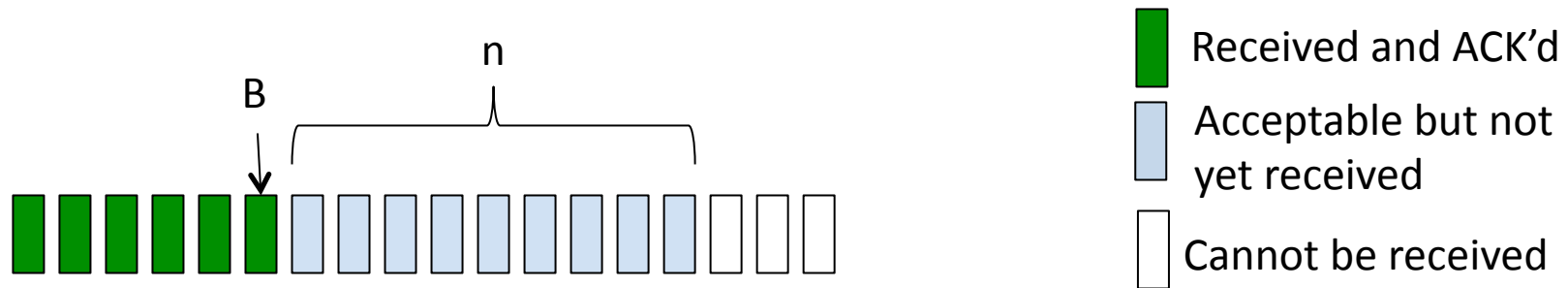

- After receiving B+1, B+2

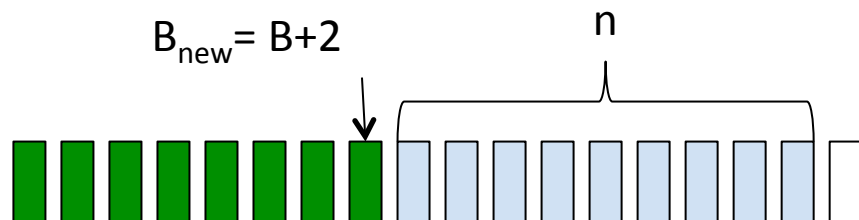

- Receiver sends ACK(B_{new}+1)

Cumulative Acknowledgements (2)

- At receiver

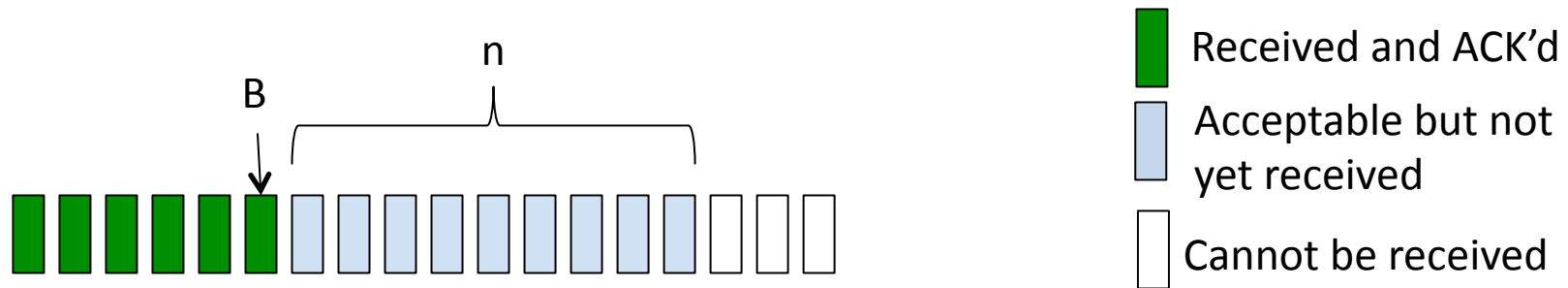

- After receiving B+4, B+5

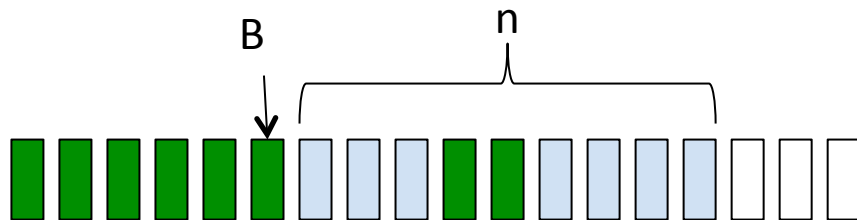

- Receiver sends **ACK(B+1)**

How do we recover?

Go-Back-N (GBN)

- Sender transmits up to n unacknowledged packets
- Receiver only accepts packets in order
 - discards out-of-order packets (i.e., packets other than $B+1$)
- Receiver uses **cumulative acknowledgements**
 - i.e., sequence# in ACK = next expected in-order sequence#
- Sender sets timer for 1st outstanding ack ($A+1$)
- If timeout, retransmit $A+1, \dots, A+n$

Sliding Window with GBN

- Let A be the **last ack'd packet of sender without gap**;
then window of sender = {A+1, A+2, ..., A+n}

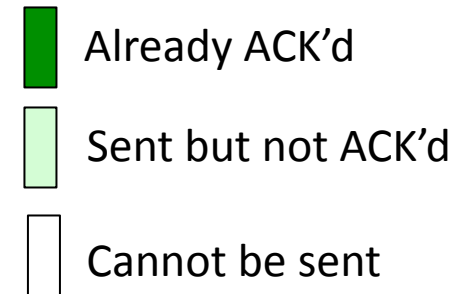
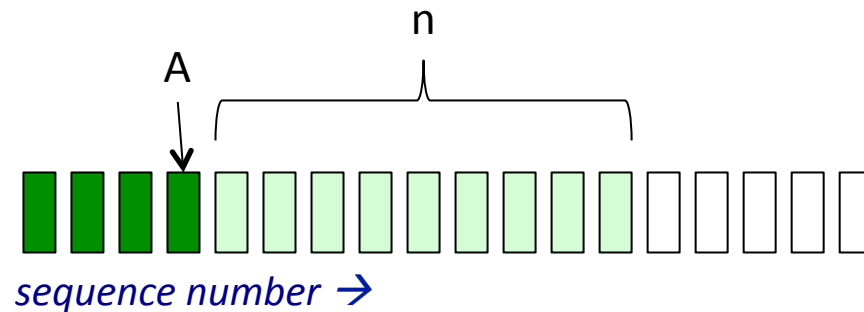

- Let B be the **last received packet without gap** by receiver,
then window of receiver = {B+1, ..., B+n}

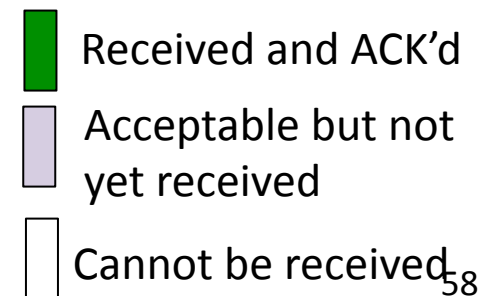
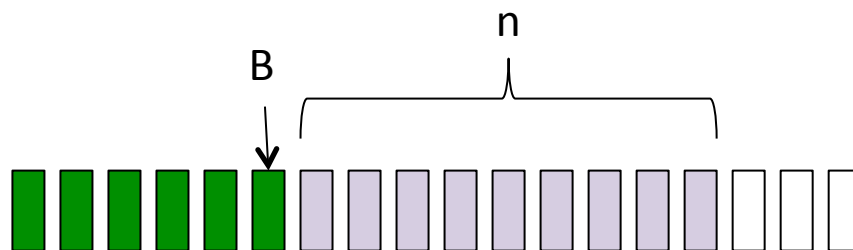

GBN Example w/o Errors

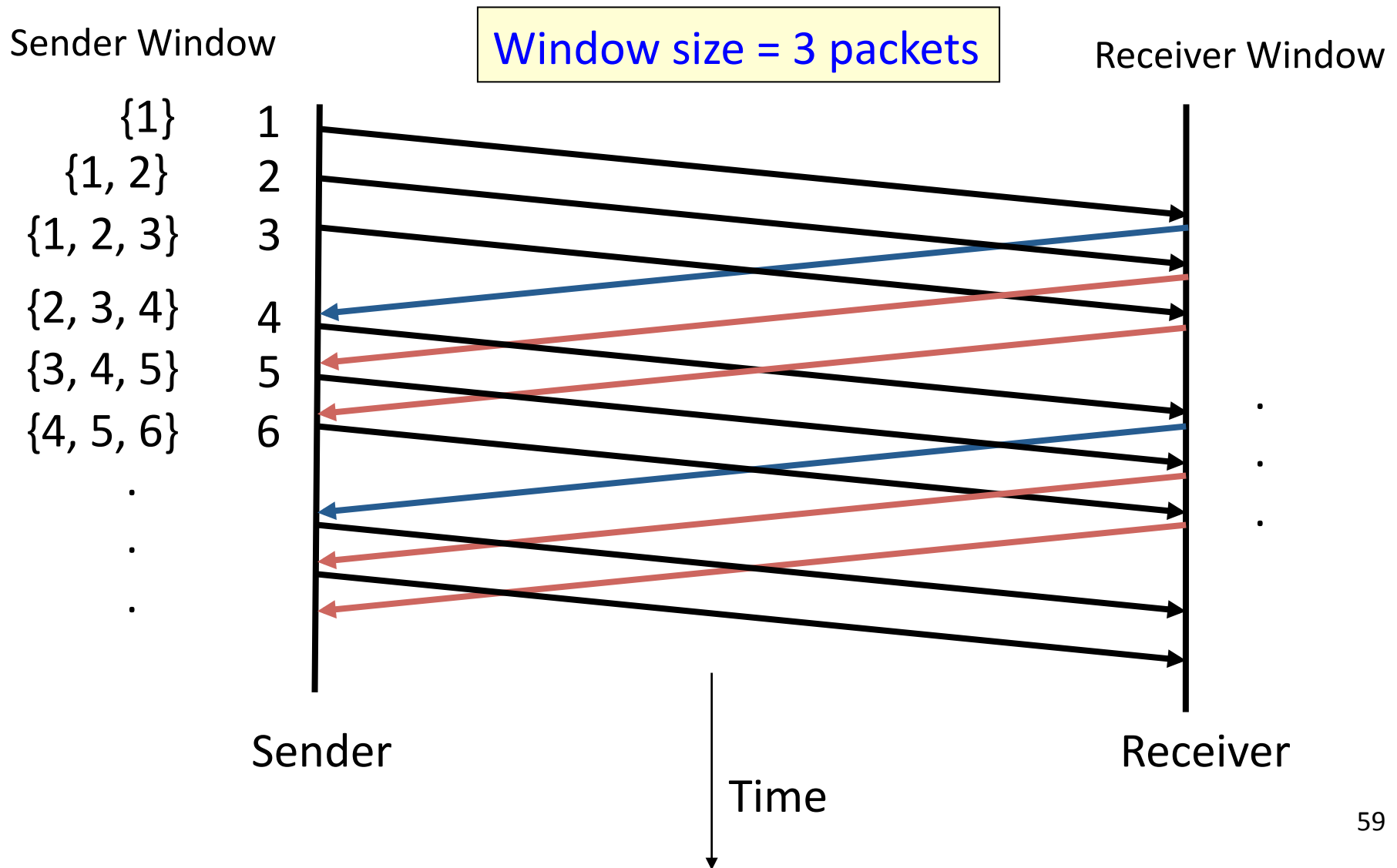

GBN Example with Errors

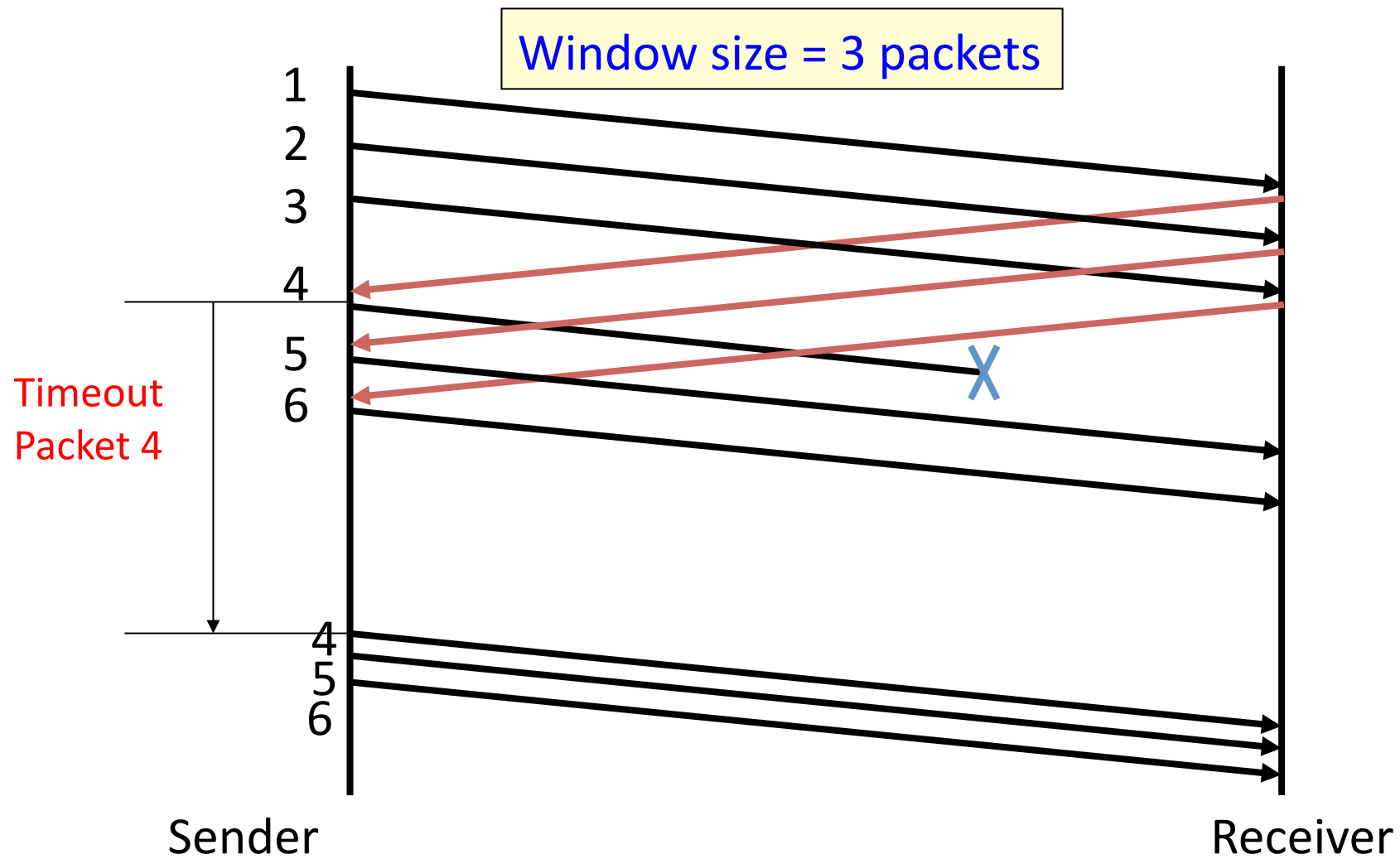

GBN: sender extended FSM

```

rdt_send(data)
if (nextseqnum < base+N) {
  udt_send(packet[nextseqnum])
  nextseqnum++
}
else
  refuse_data(data) Block?
  
```

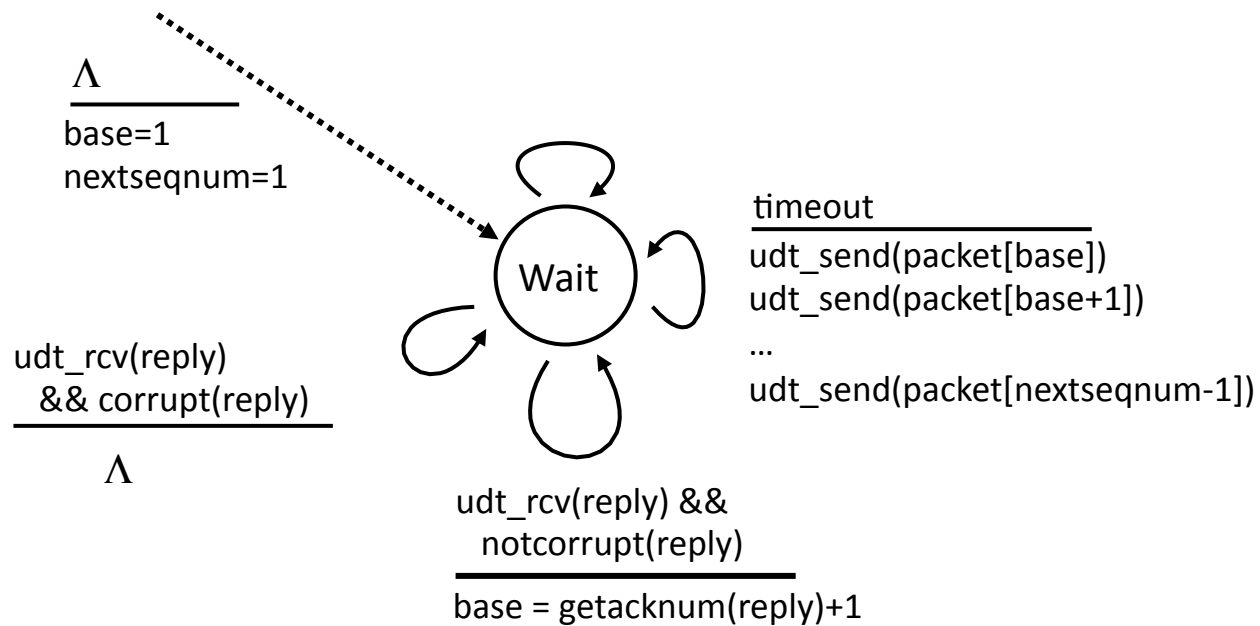

GBN: receiver extended FSM

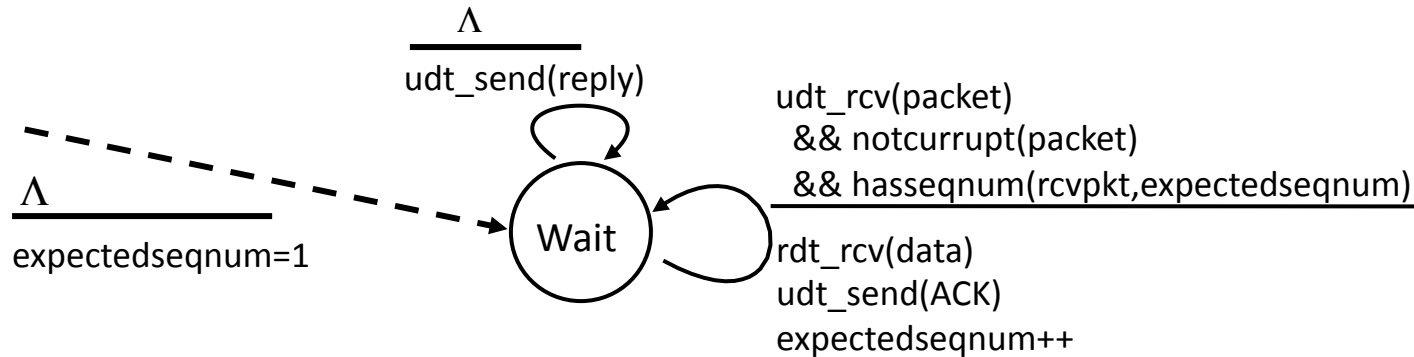

ACK-only: always send an ACK for correctly-received packet with the highest *in-order* seq #

- may generate duplicate ACKs
- need only remember **expectedseqnum**
- out-of-order packet:
 - discard (don't buffer) -> **no receiver buffering!**
 - Re-ACK packet with highest in-order seq #

Acknowledgements w/ Sliding Window

- Two common options
 - cumulative ACKs: ACK carries next in-order sequence number the receiver expects
 - selective ACKs: ACK individually acknowledges correctly received packets
- Selective ACKs offer more precise information but require more complicated book-keeping
- Many variants that differ in implementation details

Selective Repeat (SR)

- Sender: transmit up to n unacknowledged packets
- Assume packet k is lost, $k+1$ is not
- Receiver: indicates packet $k+1$ correctly received
- Sender: retransmit only packet k on timeout
- Efficient in retransmissions but complex book-keeping
 - need a timer per packet

SR Example with Errors

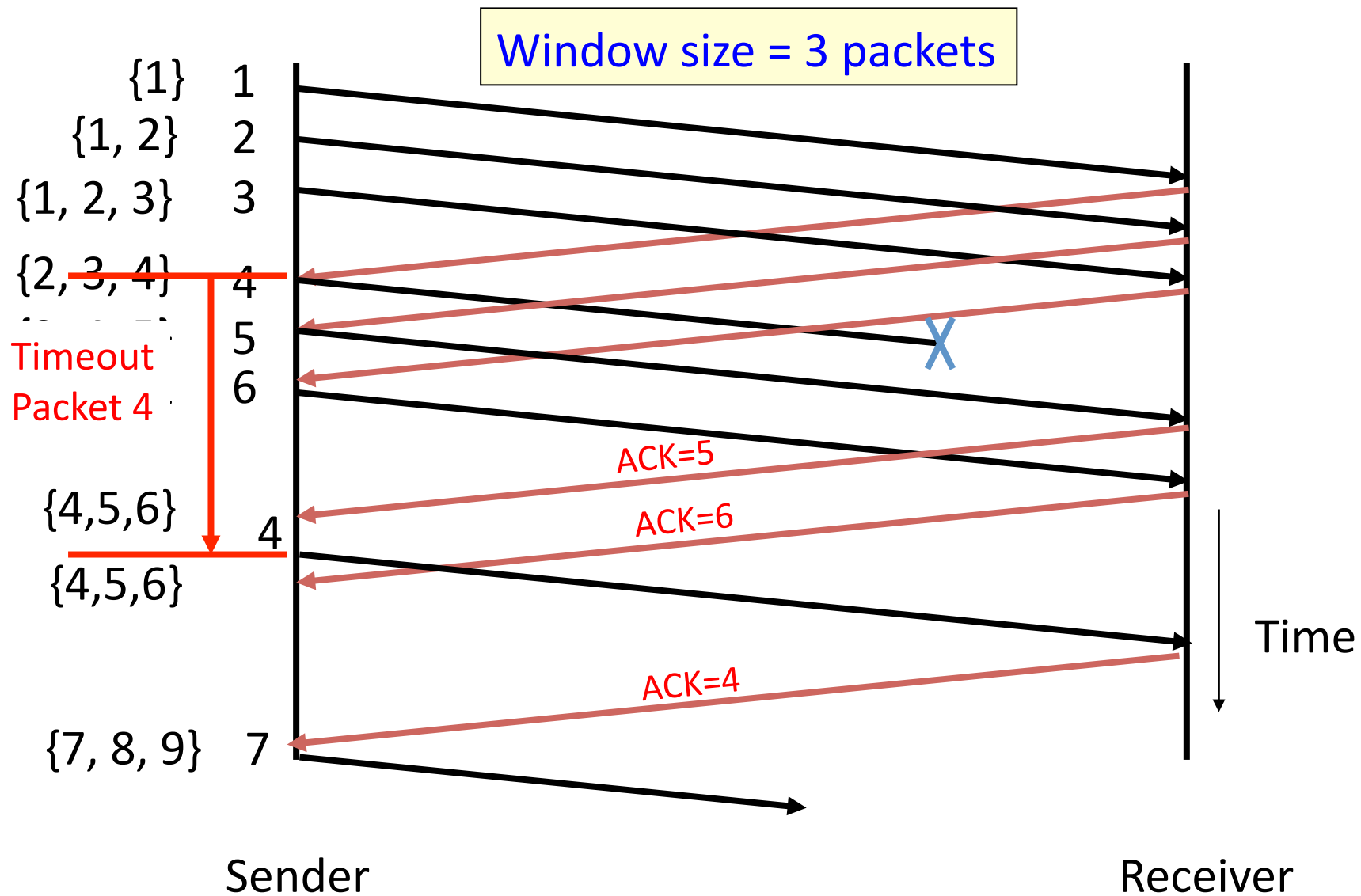

Observations

- With sliding windows, it is possible to fully utilize a link, provided the window size is large enough.
Throughput is $\sim (n/RTT)$
 - Stop & Wait is like $n = 1$.
- Sender has to buffer all unacknowledged packets, because they may require retransmission
- Receiver may be able to accept out-of-order packets, but only up to its buffer limits
- Implementation complexity depends on protocol details (GBN vs. SR)

Recap: components of a solution

- Checksums (for error detection)
- Timers (for loss detection)
- Acknowledgments
 - cumulative
 - selective
- Sequence numbers (duplicates, windows)
- Sliding Windows (for efficiency)

- Reliability protocols use the above to decide when and what to retransmit or acknowledge

What does TCP do?

Most of our previous tricks + a few differences

- Sequence numbers are byte offsets
- Sender and receiver maintain a sliding window
- Receiver sends cumulative acknowledgements (like GBN)
- Sender maintains a single retx. timer
- Receivers do not drop out-of-sequence packets (like SR)
- Introduces **fast retransmit** : optimization that uses duplicate ACKs to trigger early retx (next time)
- Introduces timeout estimation algorithms (next time)

Automatic Repeat Request (ARQ)

+ Self-clocking (Automatic)

Next lets move from
the generic to the
specific....

+ Adaptive

+ Flexible

TCP arguably the most
successful protocol in the
Internet.....

- Slow to start / adapt

consider high Bandwidth/Delay product

its an ARQ protocol

TCP Header

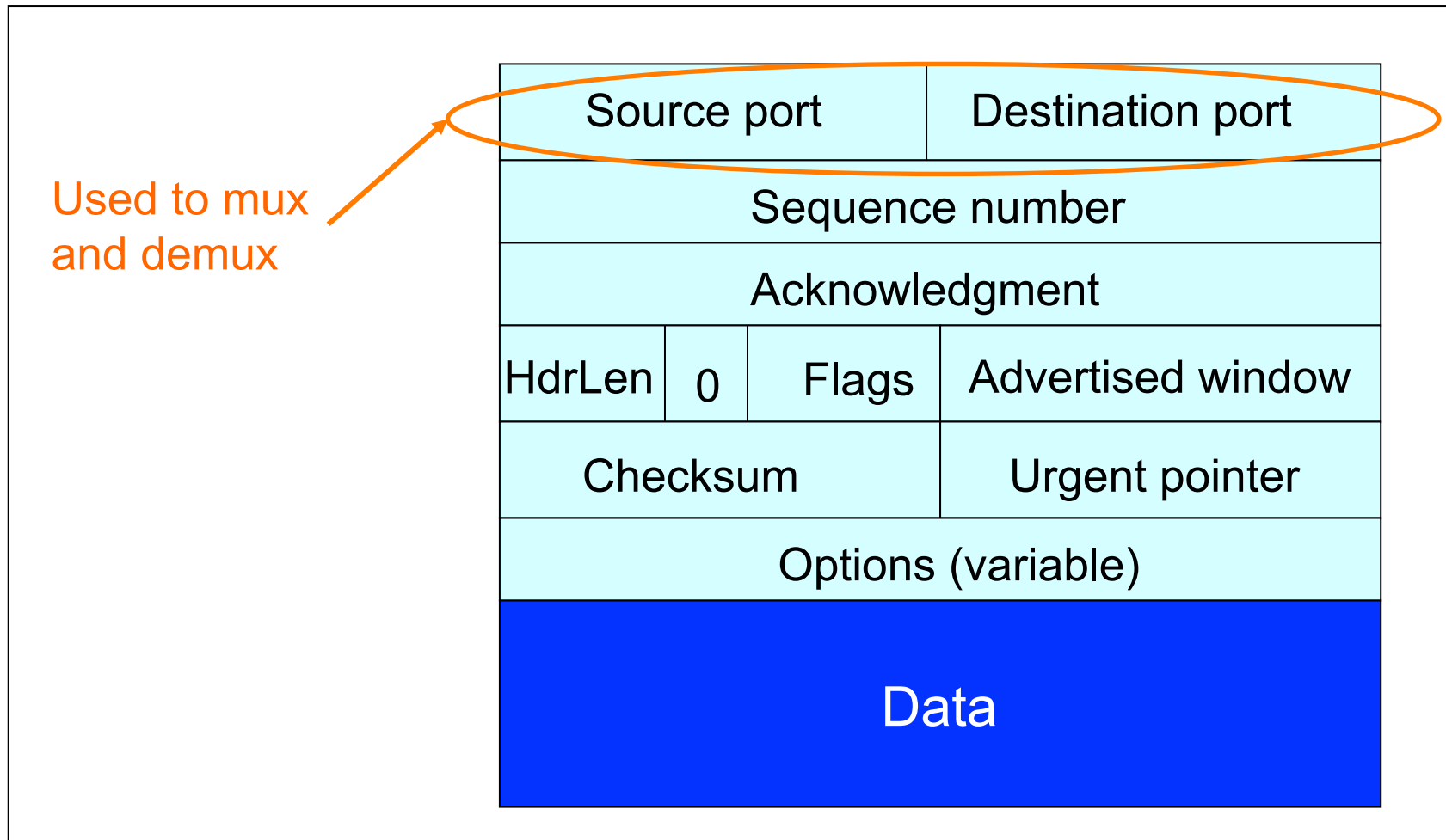

Last time: Components of a solution for reliable transport

- Checksums (for error detection)
- Timers (for loss detection)
- Acknowledgments
 - cumulative
 - selective
- Sequence numbers (duplicates, windows)
- Sliding Windows (for efficiency)
 - Go-Back-N (GBN)
 - Selective Replay (SR)

What does TCP do?

Many of our previous ideas, but some key differences

- Checksum

TCP Header

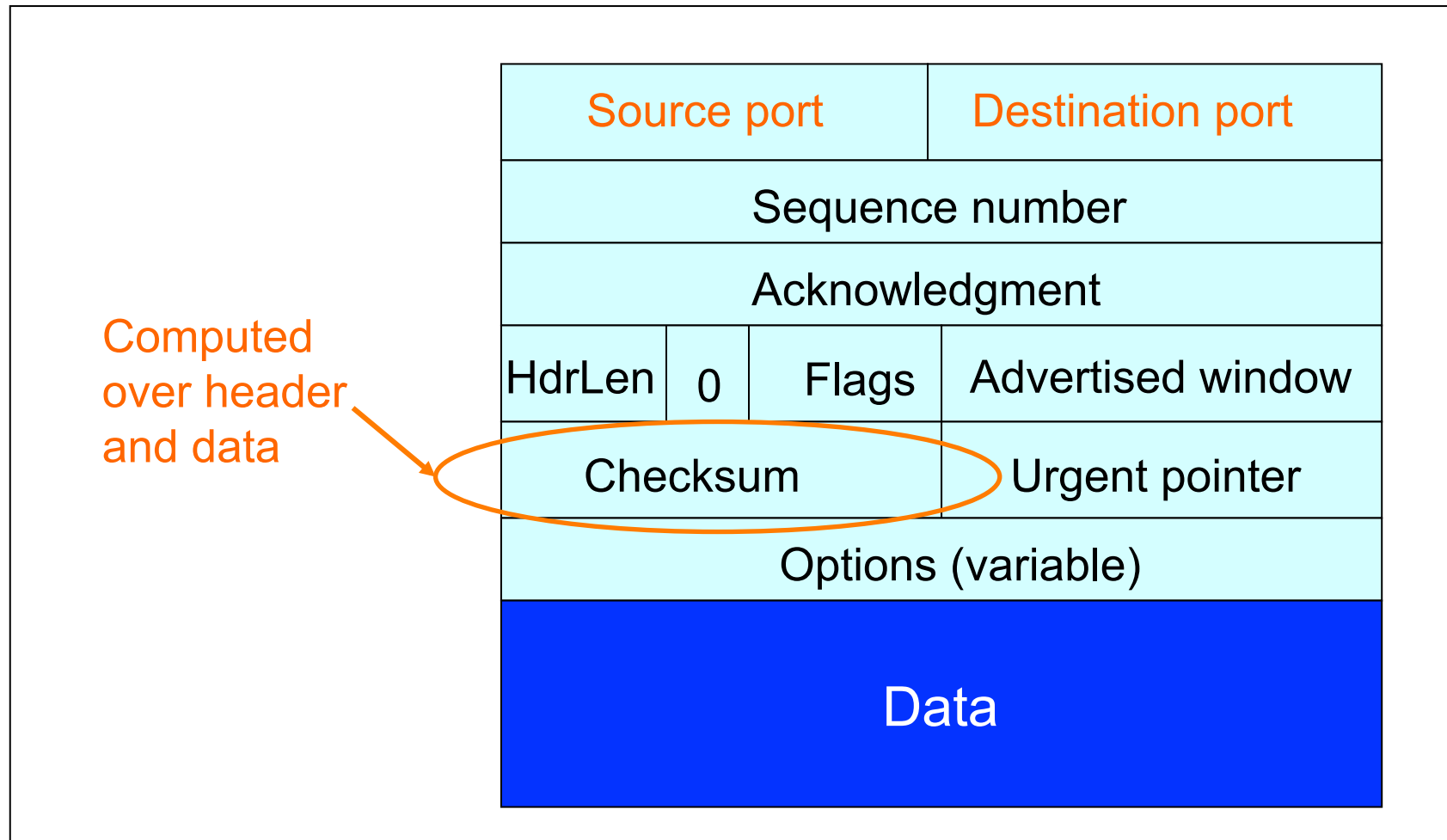

What does TCP do?

Many of our previous ideas, but some key differences

- Checksum
- **Sequence numbers are byte offsets**

TCP: Segments and Sequence Numbers

TCP “Stream of Bytes” Service...

Application @ Host A

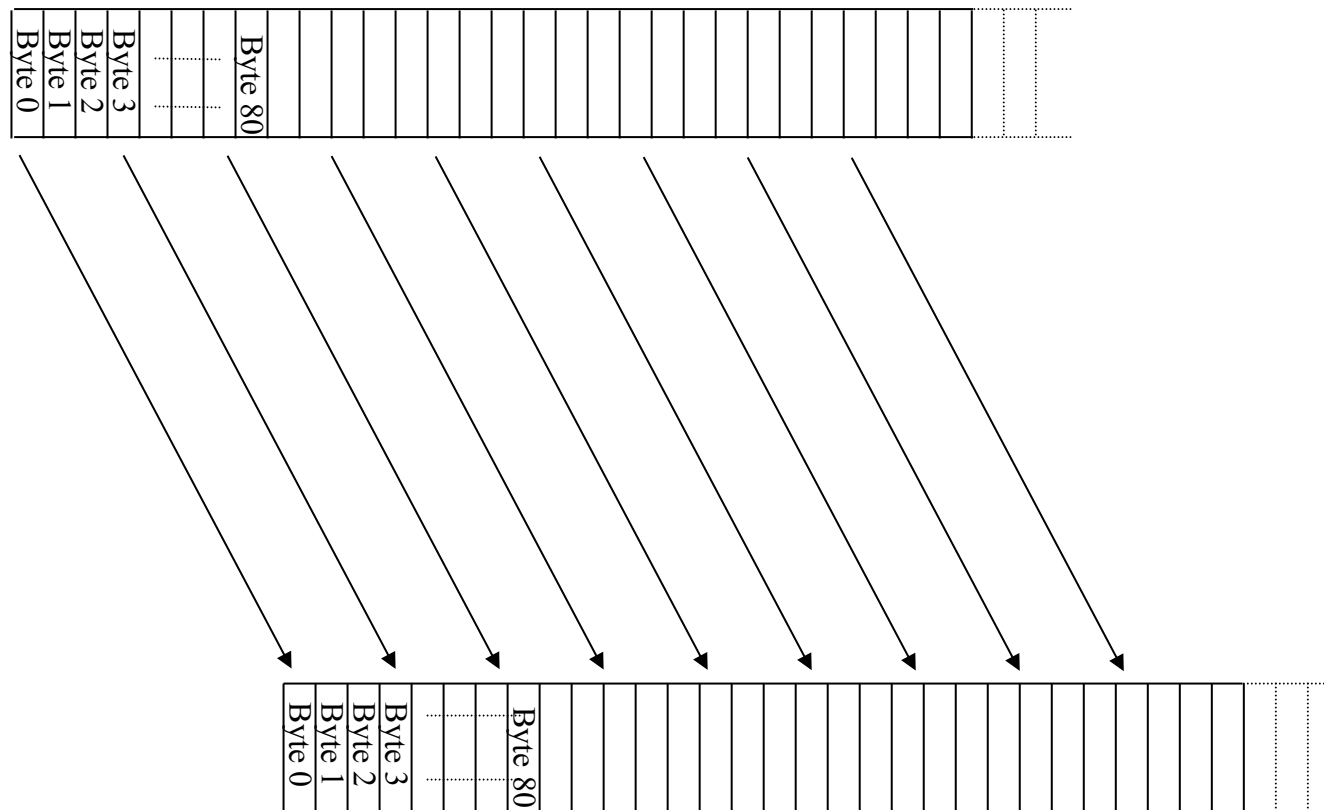

Application @ Host B

... Provided Using TCP “Segments”

Host A

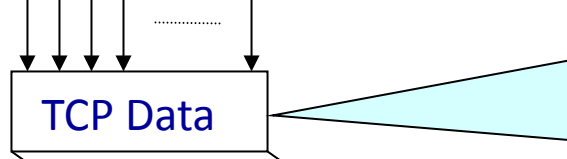
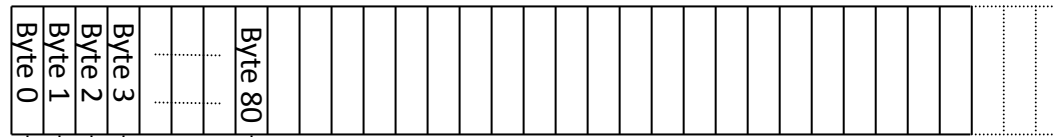

Segment sent when:

1. Segment full (Max Segment Size),
2. Not full, but times out

Host B

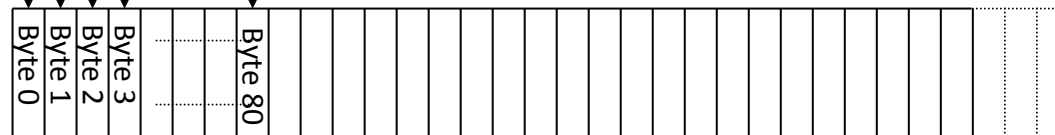

TCP Segment

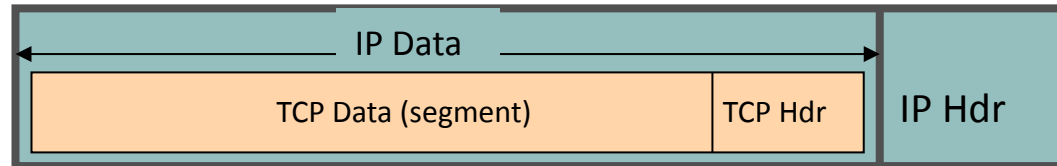

- IP packet
 - No bigger than Maximum Transmission Unit (**MTU**)
 - E.g., up to 1500 bytes with Ethernet
- TCP packet
 - IP packet with a TCP header and data inside
 - TCP header ≥ 20 bytes long
- **TCP segment**
 - No more than **Maximum Segment Size** (MSS) bytes
 - E.g., up to 1460 consecutive bytes from the stream
 - $MSS = MTU - (IP\ header) - (TCP\ header)$

Sequence Numbers

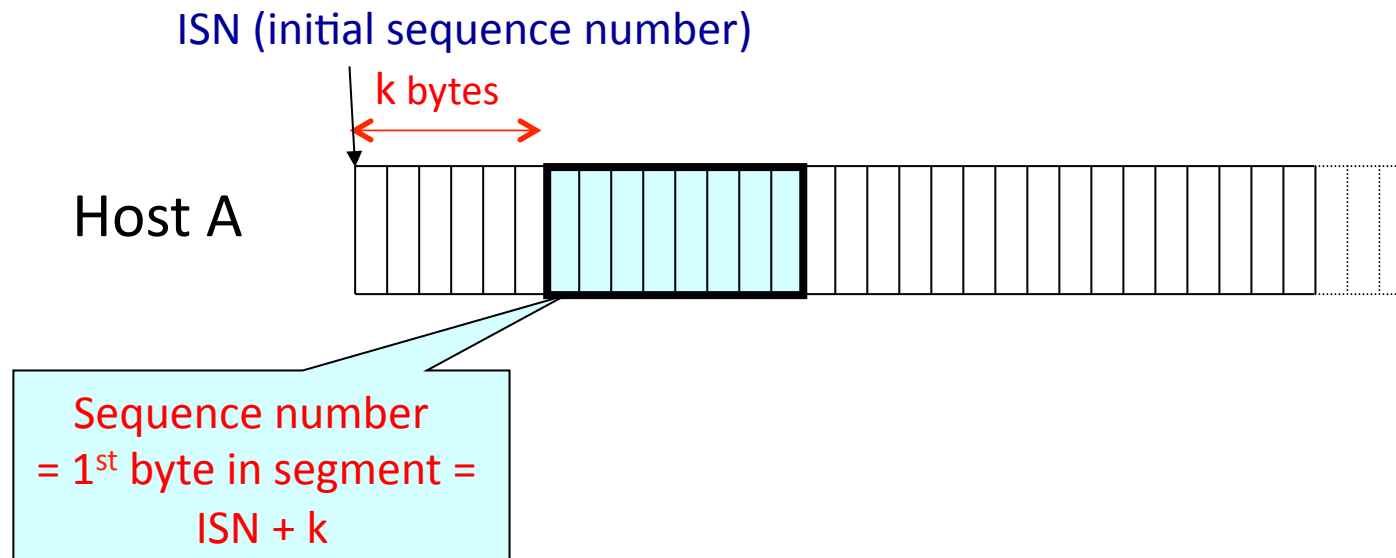

Sequence Numbers

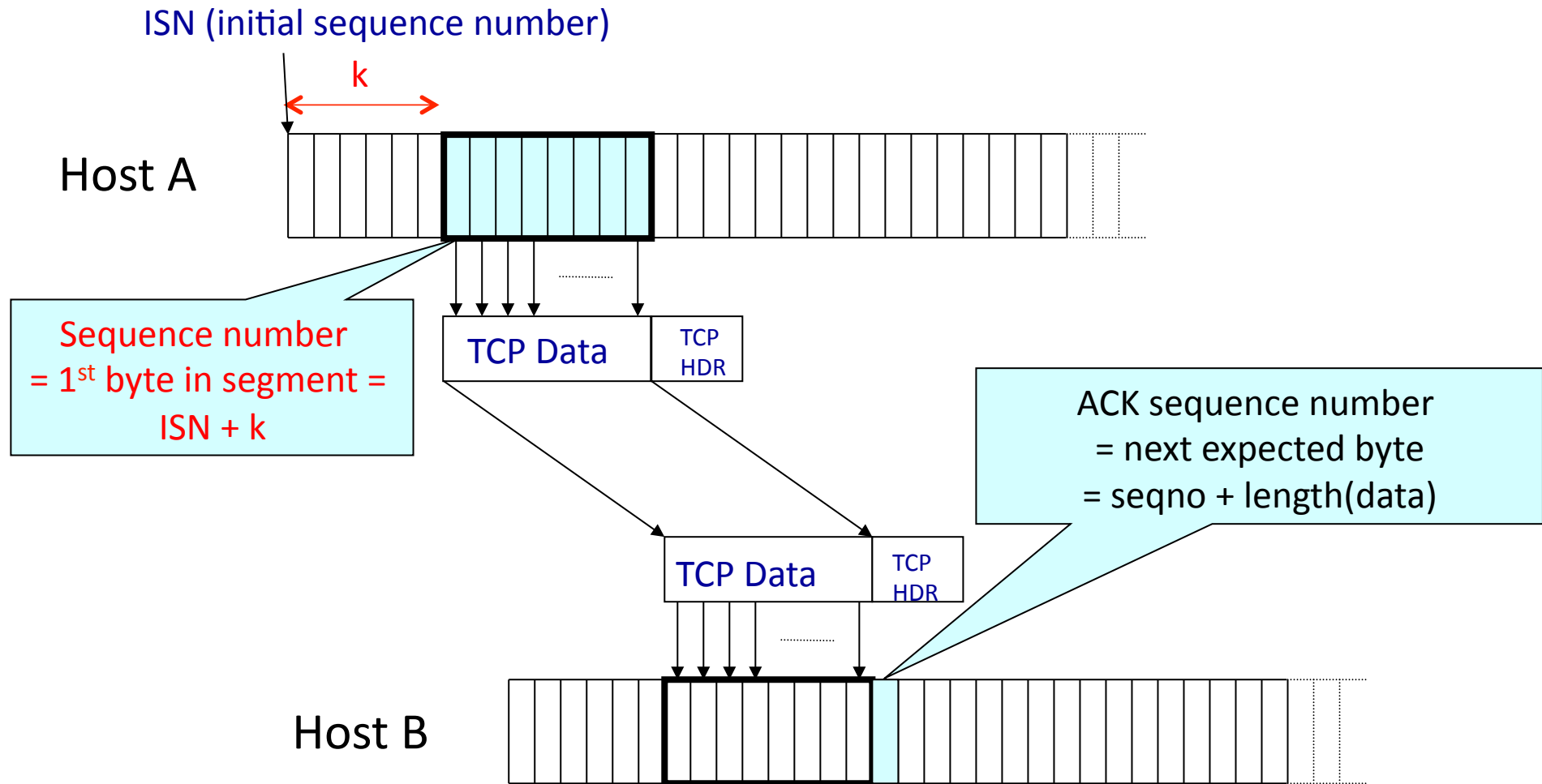

TCP Header

Starting byte
offset of data
carried in this
segment

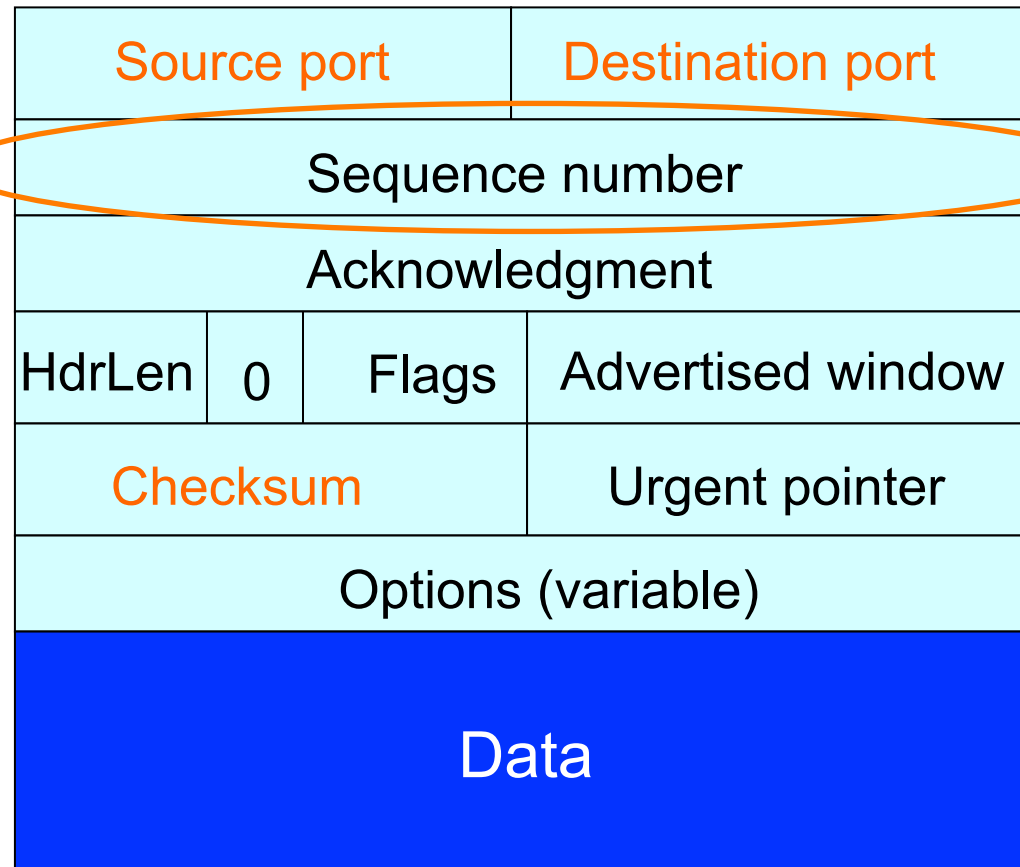

- What does TCP do?

What does TCP do?

Most of our previous tricks, but a few differences

- Checksum
- Sequence numbers are byte offsets
- Receiver sends cumulative acknowledgements (like GBN)

ACKing and Sequence Numbers

- Sender sends packet
 - Data starts with sequence number X
 - Packet contains B bytes [$X, X+1, X+2, \dots, X+B-1$]
- Upon receipt of packet, receiver sends an ACK
 - If all data prior to X already received:
 - ACK acknowledges $X+B$ (because that is next expected byte)
 - If highest in-order byte received is Y s.t. $(Y+1) < X$
 - ACK acknowledges $Y+1$
 - Even if this has been ACKed before

Normal Pattern

- Sender: seqno= X , length= B
- Receiver: ACK= $X+B$
- Sender: seqno= $X+B$, length= B
- Receiver: ACK= $X+2B$
- Sender: seqno= $X+2B$, length= B

- Seqno of next packet is same as last ACK field

TCP Header

Acknowledgment gives seqno just beyond highest seqno received **in order** (“*What Byte is Next*”)

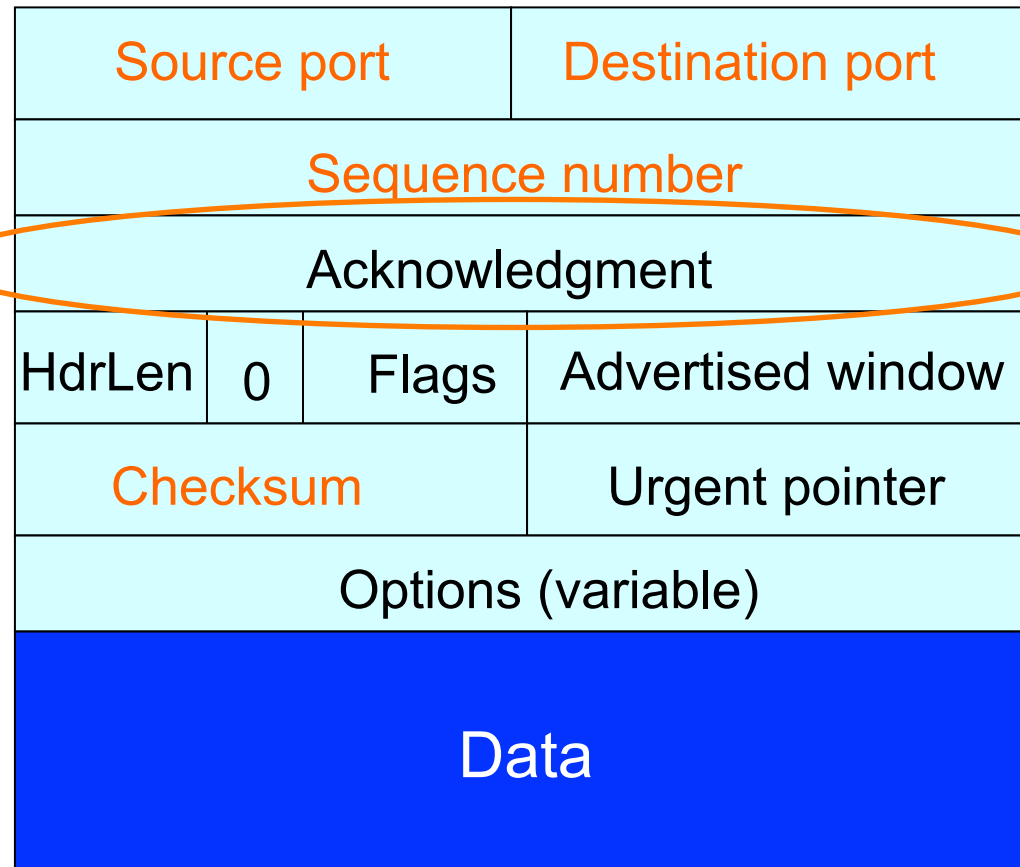

What does TCP do?

Most of our previous tricks, but a few differences

- Checksum
- Sequence numbers are byte offsets
- Receiver sends cumulative acknowledgements (like GBN)
- Receivers **can** buffer out-of-sequence packets (like SR)

Loss with cumulative ACKs

- Sender sends packets with 100B and seqnos.:
 - 100, 200, 300, 400, 500, 600, 700, 800, 900, ...
- Assume the fifth packet (seqno 500) is lost, but no others
- Stream of ACKs will be:
 - 200, 300, 400, 500, 500, 500, 500, ...

What does TCP do?

Most of our previous tricks, but a few differences

- Checksum
- Sequence numbers are byte offsets
- Receiver sends cumulative acknowledgements (like GBN)
- Receivers may not drop out-of-sequence packets (like SR)
- Introduces **fast retransmit**: optimization that uses duplicate ACKs to trigger early retransmission

Loss with cumulative ACKs

- “Duplicate ACKs” are a sign of an isolated loss
 - The lack of ACK progress means 500 hasn’t been delivered
 - Stream of ACKs means some packets are being delivered
- Therefore, could trigger resend upon receiving k duplicate ACKs
 - TCP uses $k=3$
- But response to loss is trickier....

Loss with cumulative ACKs

- Two choices:
 - Send missing packet and increase W by the number of dup ACKs
 - Send missing packet, and wait for ACK to increase W
- Which should TCP do?

What does TCP do?

Most of our previous tricks, but a few differences

- Checksum
- Sequence numbers are byte offsets
- Receiver sends cumulative acknowledgements (like GBN)
- Receivers do not drop out-of-sequence packets (like SR)
- Introduces fast retransmit: optimization that uses duplicate ACKs to trigger early retransmission
- Sender maintains a single retransmission timer (like GBN) and retransmits on timeout

Retransmission Timeout

- If the sender hasn't received an ACK by timeout, retransmit the first packet in the window
- How do we pick a timeout value?

Timing Illustration

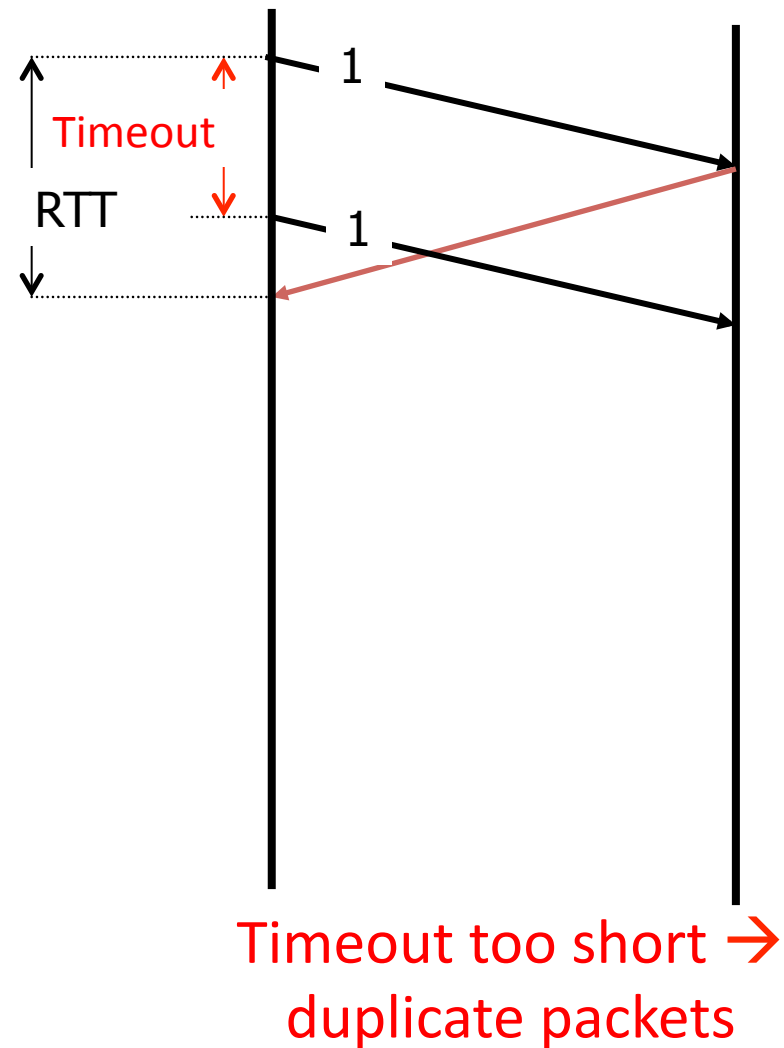
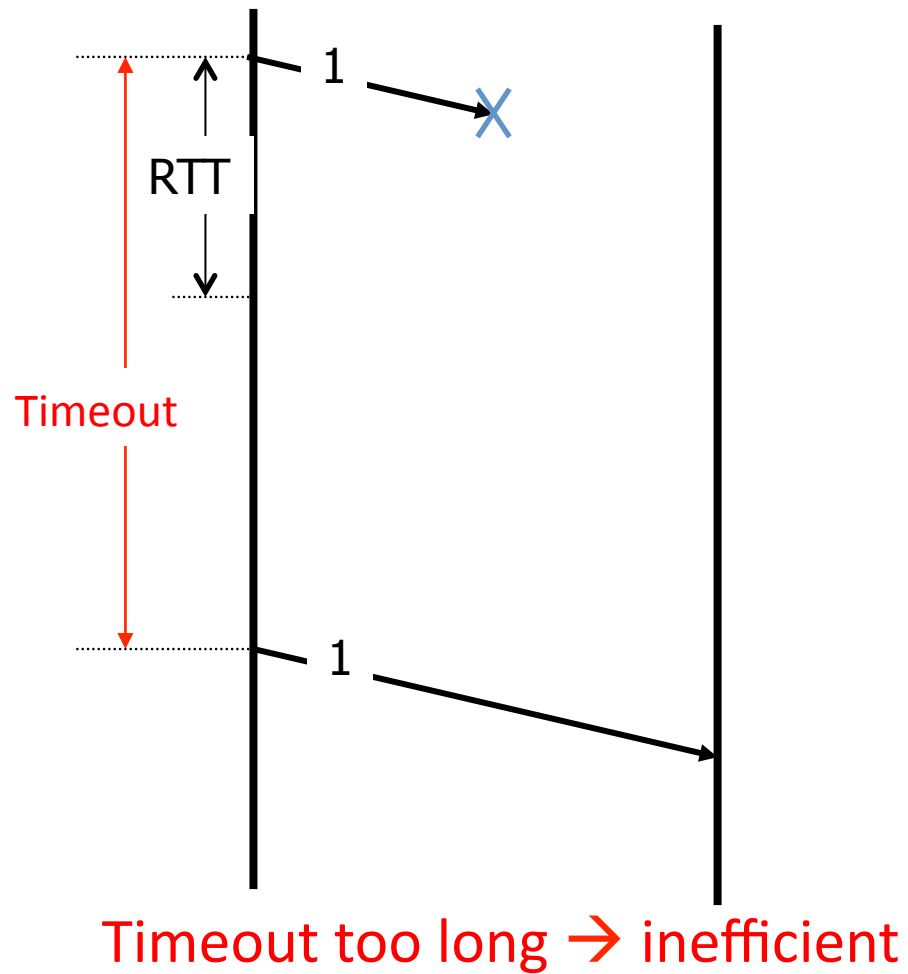

Retransmission Timeout

- If haven't received ack by timeout, retransmit the first packet in the window
- How to set timeout?
 - Too long: connection has low throughput
 - Too short: retransmit packet that was just delayed
- Solution: make timeout proportional to RTT
- But how do we measure RTT?

RTT Estimation

- Use exponential averaging of RTT samples

$$\text{SampleRTT} = \text{AckRcvdTime} - \text{SendPacketTime}$$

$$\text{EstimatedRTT} = \alpha \times \text{EstimatedRTT} + (1 - \alpha) \times \text{SampleRTT}$$

$$0 < \alpha \leq 1$$

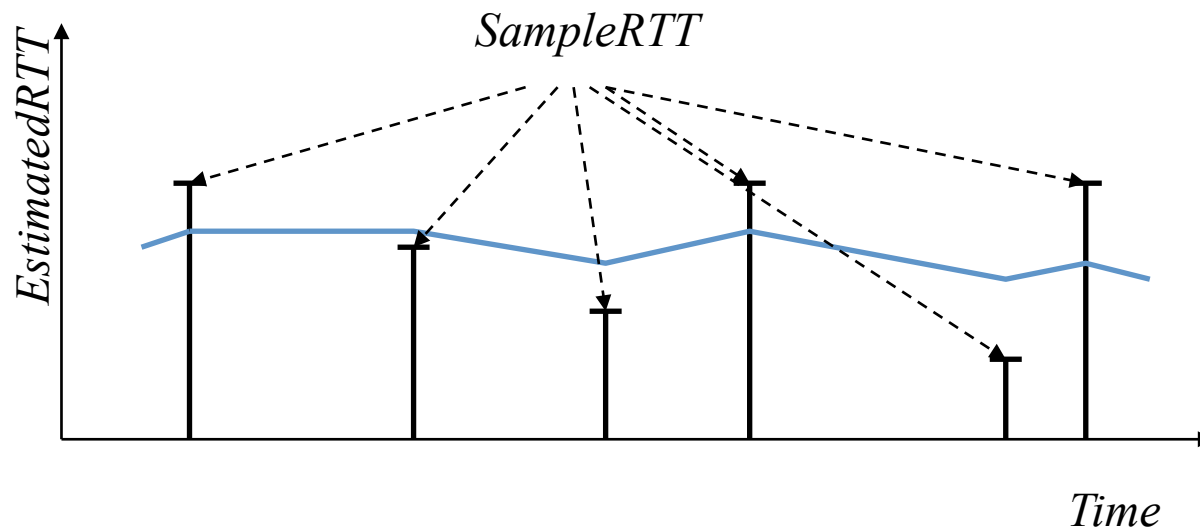

Exponential Averaging Example

$$\text{EstimatedRTT} = \alpha * \text{EstimatedRTT} + (1 - \alpha) * \text{SampleRTT}$$

Assume RTT is constant \rightarrow $\text{SampleRTT} = \text{RTT}$

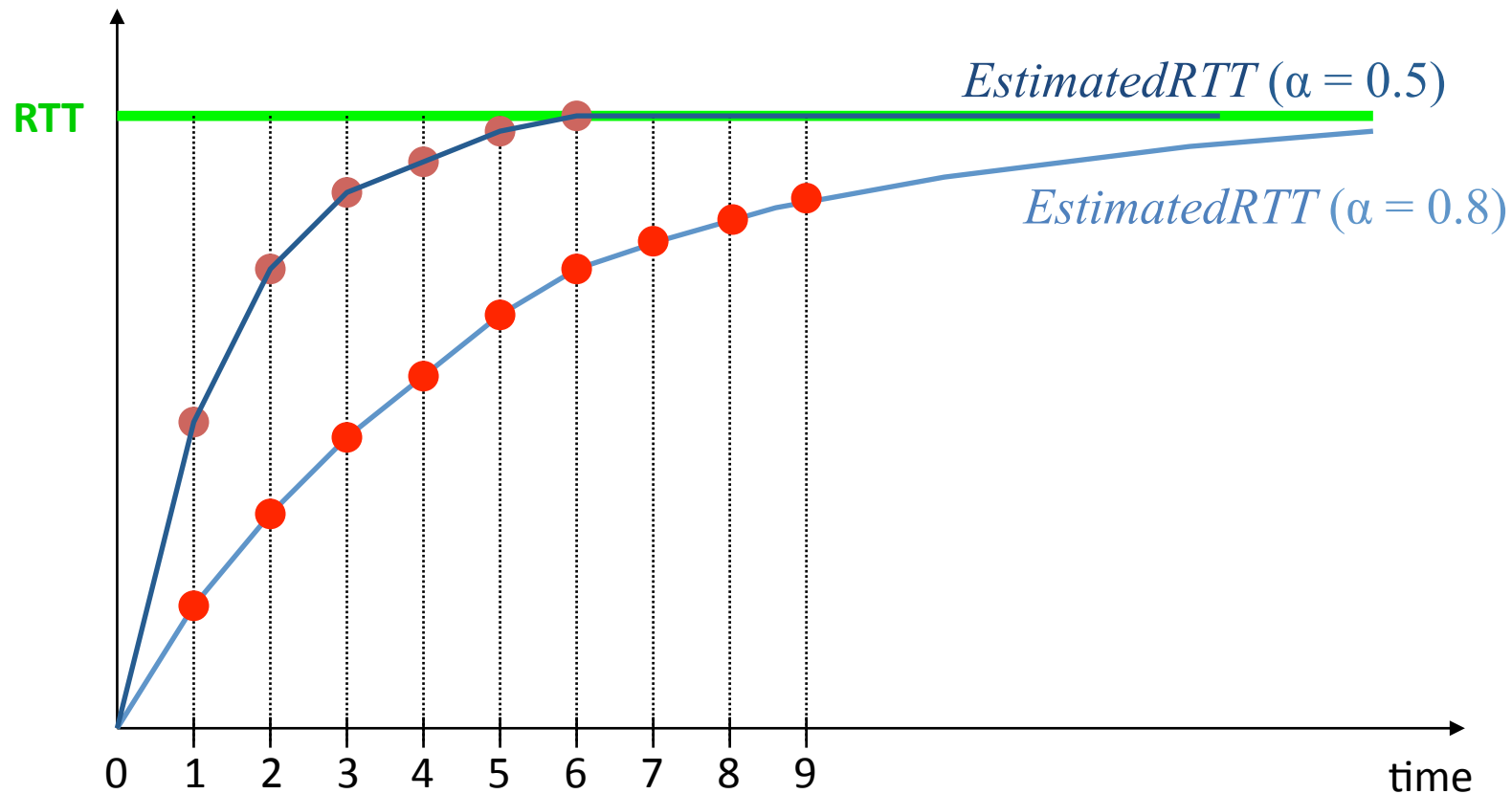

Problem: Ambiguous Measurements

- How do we differentiate between the real ACK, and ACK of the retransmitted packet?

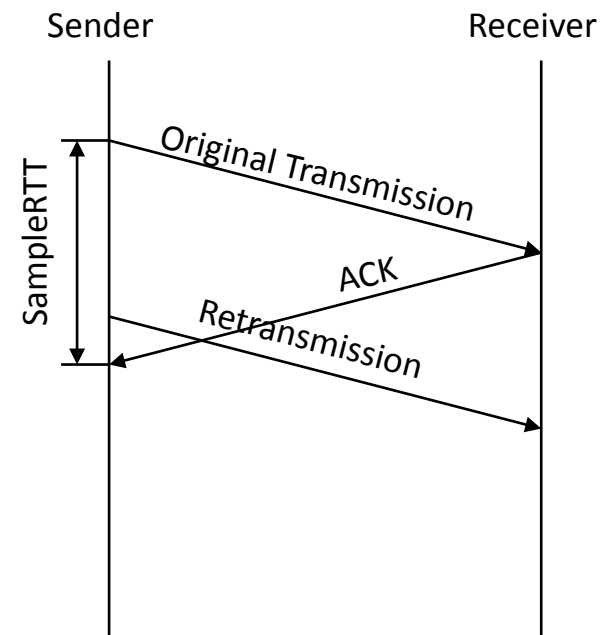
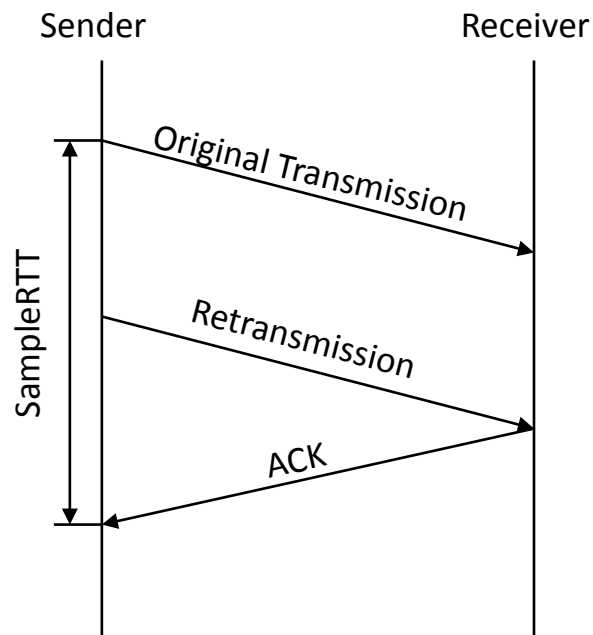

Karn/Partridge Algorithm

- Measure *SampleRTT* only for original transmissions
 - Once a segment has been retransmitted, do not use it for any further measurements
- Computes EstimatedRTT using $\alpha = 0.875$
- Timeout value (RTO) = $2 \times$ EstimatedRTT
- Employs **exponential backoff**
 - Every time RTO timer expires, set $RTO \leftarrow 2 \cdot RTO$
 - (Up to maximum ≥ 60 sec)
 - Every time new measurement comes in (= successful original transmission), collapse RTO back to $2 \times$ EstimatedRTT

Karn/Partridge in action

Figure 5: Performance of an RFC793 retransmit timer

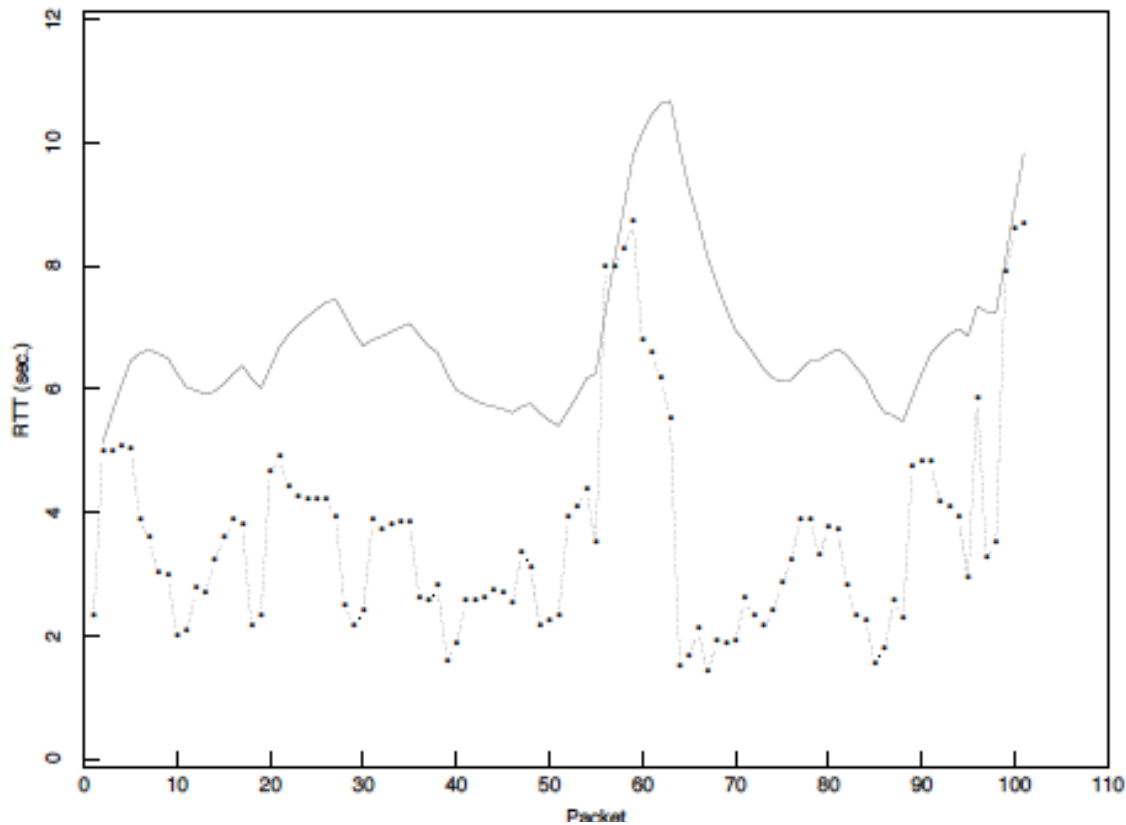

from Jacobson and Karels, SIGCOMM 1988

Jacobson/Karels Algorithm

- Problem: need to better capture variability in RTT
 - Directly measure **deviation**
- Deviation = $| \text{SampleRTT} - \text{EstimatedRTT} |$
- EstimatedDeviation: exponential average of Deviation
- $\text{RTO} = \text{EstimatedRTT} + 4 \times \text{EstimatedDeviation}$

With Jacobson/Karels

Figure 5: Performance of an RFC793 retransmit timer

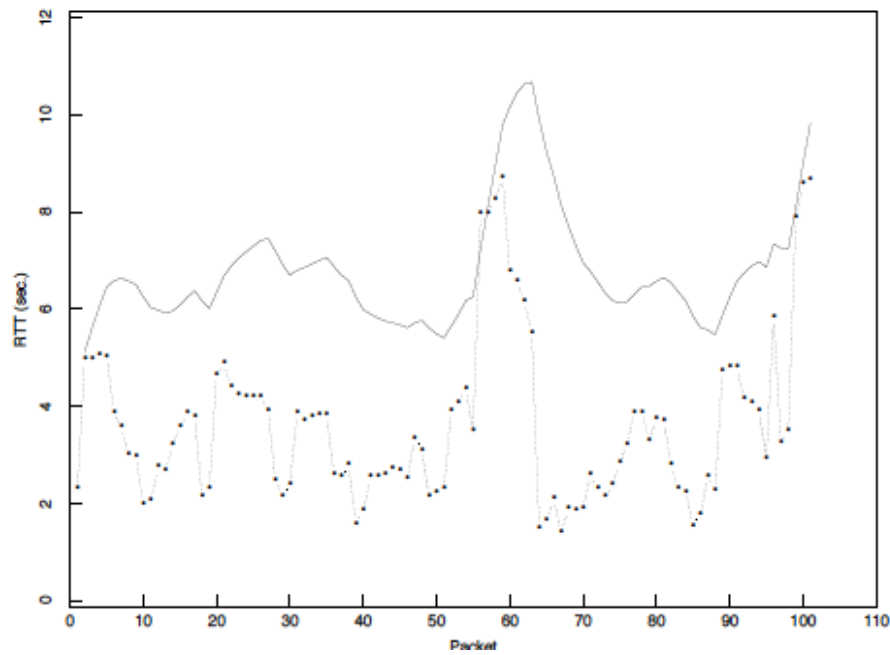
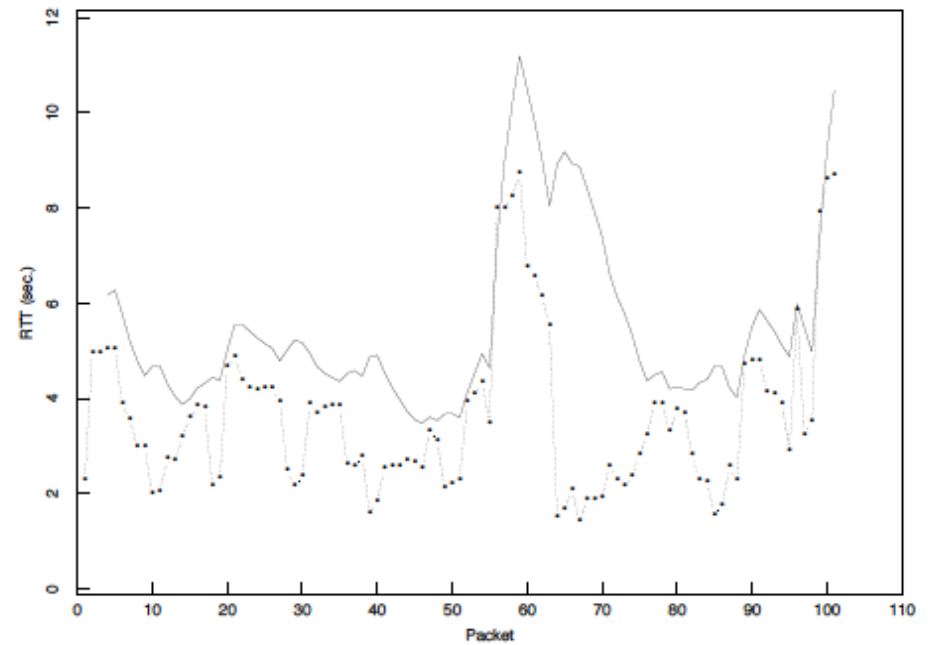

Figure 6: Performance of a Mean+Variance retransmit timer



What does TCP do?

Most of our previous ideas, but some key differences

- Checksum
- Sequence numbers are byte offsets
- Receiver sends cumulative acknowledgements (like GBN)
- Receivers do not drop out-of-sequence packets (like SR)
- Introduces fast retransmit: optimization that uses duplicate ACKs to trigger early retransmission
- Sender maintains a single retransmission timer (like GBN) and retransmits on timeout

TCP Header: What's left?

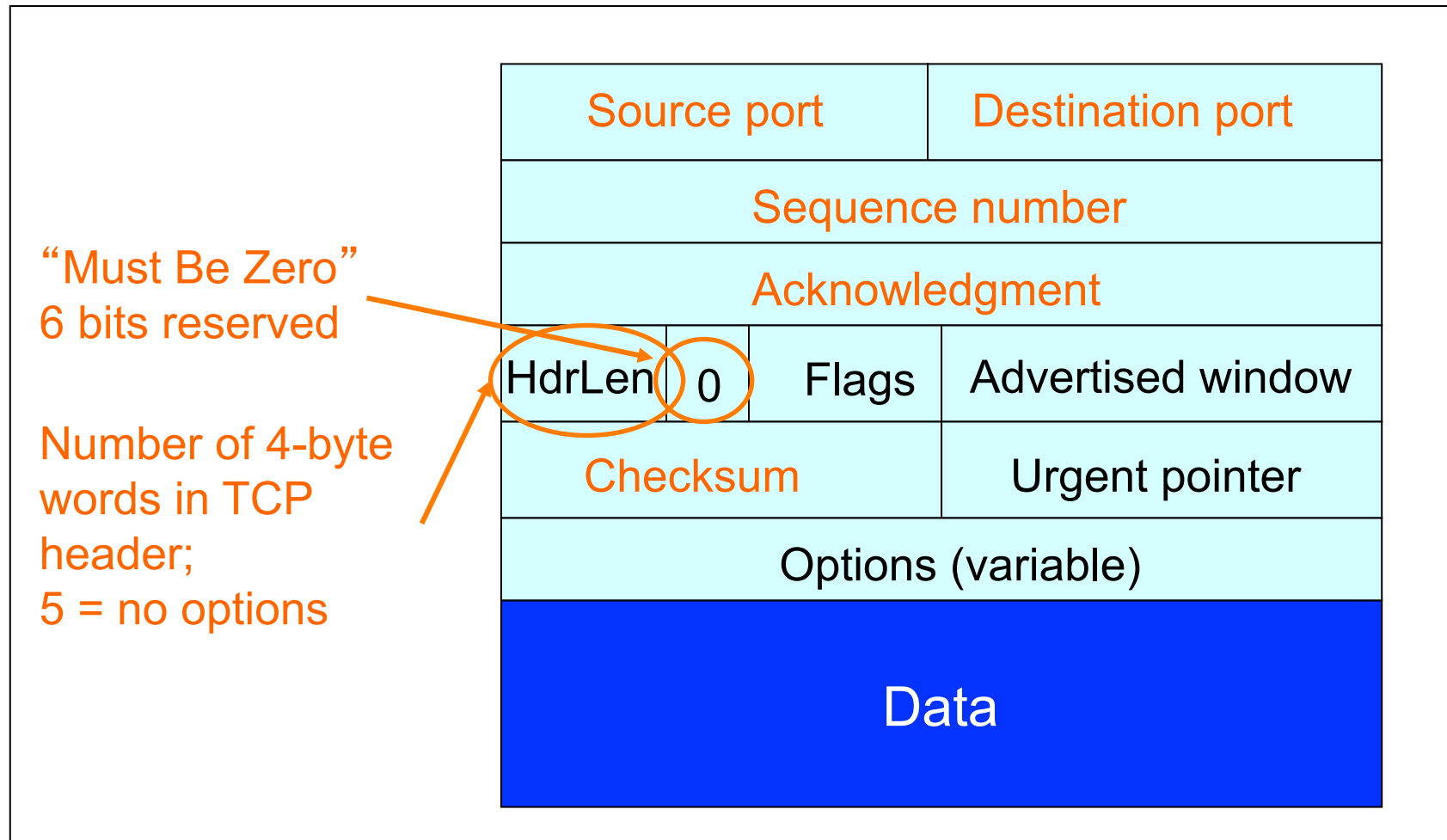

TCP Header: What's left?

Used with **URG** flag to indicate urgent data (not discussed further)

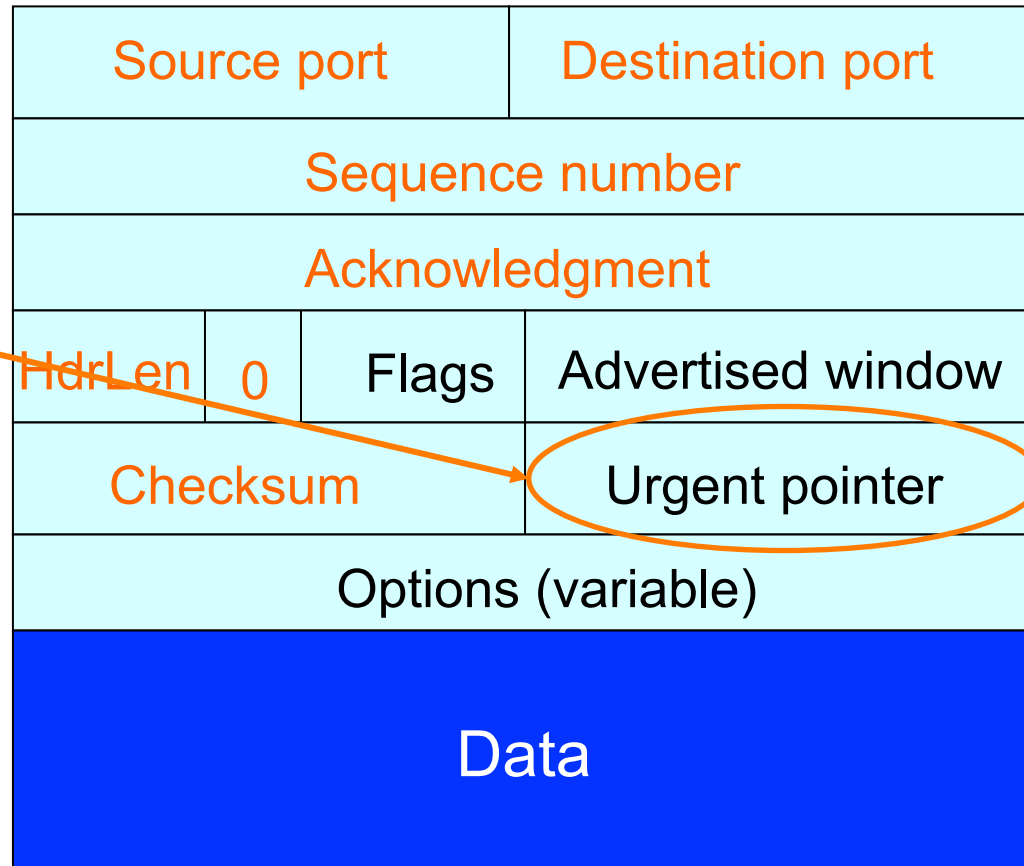

TCP Header: What's left?

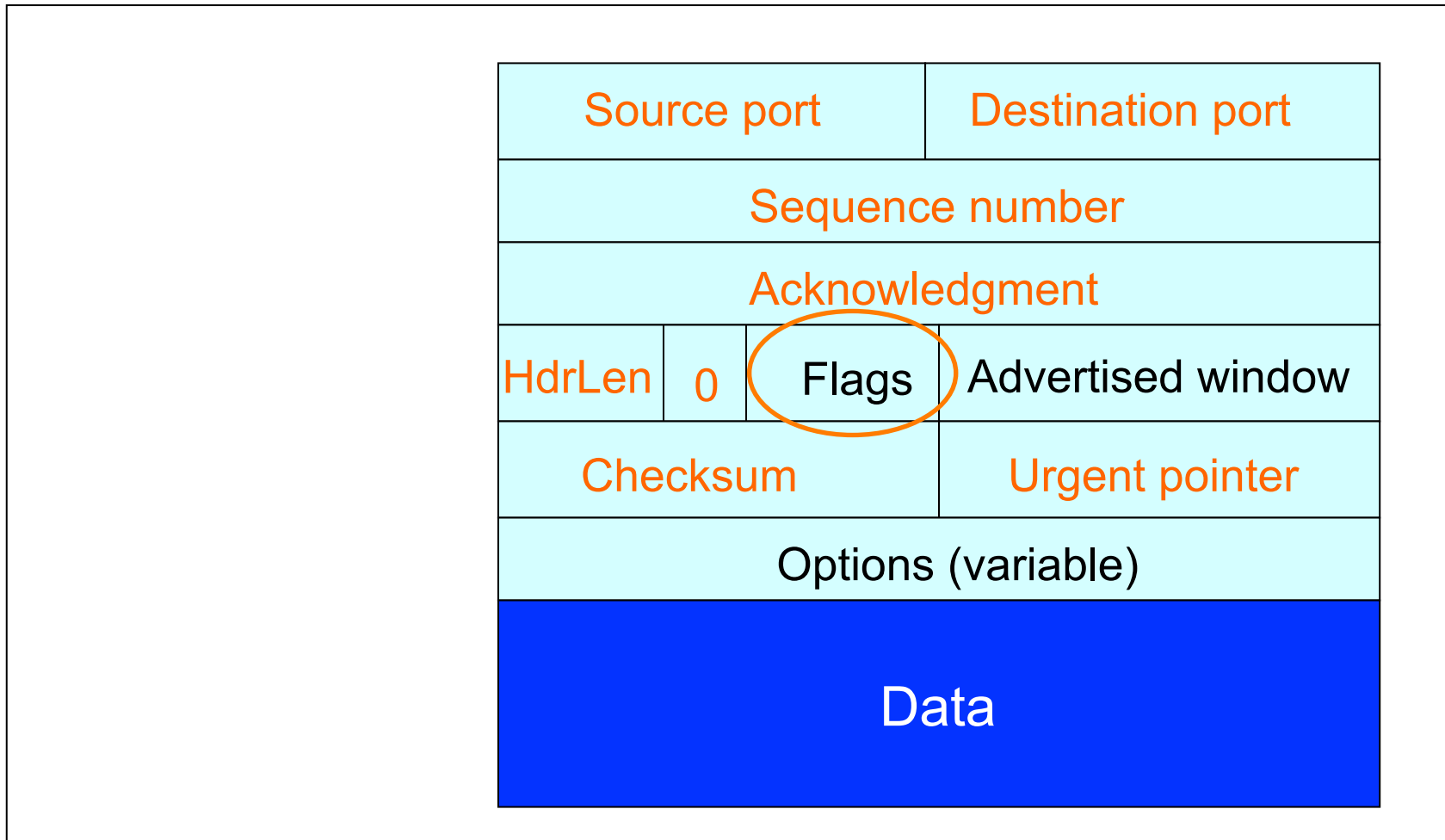

TCP Connection Establishment and Initial Sequence Numbers

Initial Sequence Number (ISN)

- Sequence number for the very first byte
- Why not just use ISN = 0?
- Practical issue
 - IP addresses and port #s uniquely identify a connection
 - Eventually, though, these port #s do get **used again**
 - ... small chance an old packet is **still in flight**
- TCP therefore **requires** changing ISN
- Hosts exchange ISNs when they establish a connection

Establishing a TCP Connection

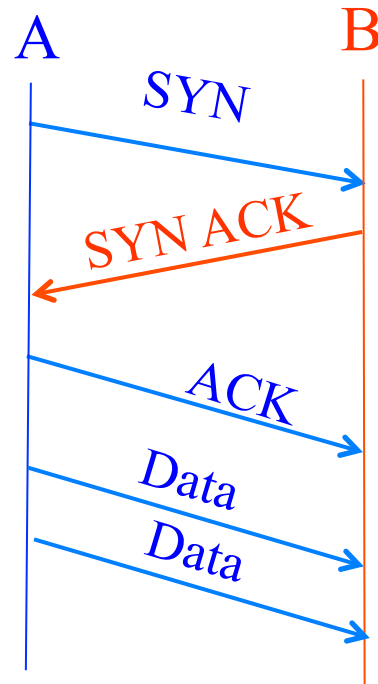

Each host tells its ISN to the other host.

- Three-way handshake to establish connection
 - Host A sends a **SYN** (open; “synchronize sequence numbers”) to host B
 - Host B returns a SYN acknowledgment (**SYN ACK**)
 - Host A sends an **ACK** to acknowledge the SYN ACK

TCP Header

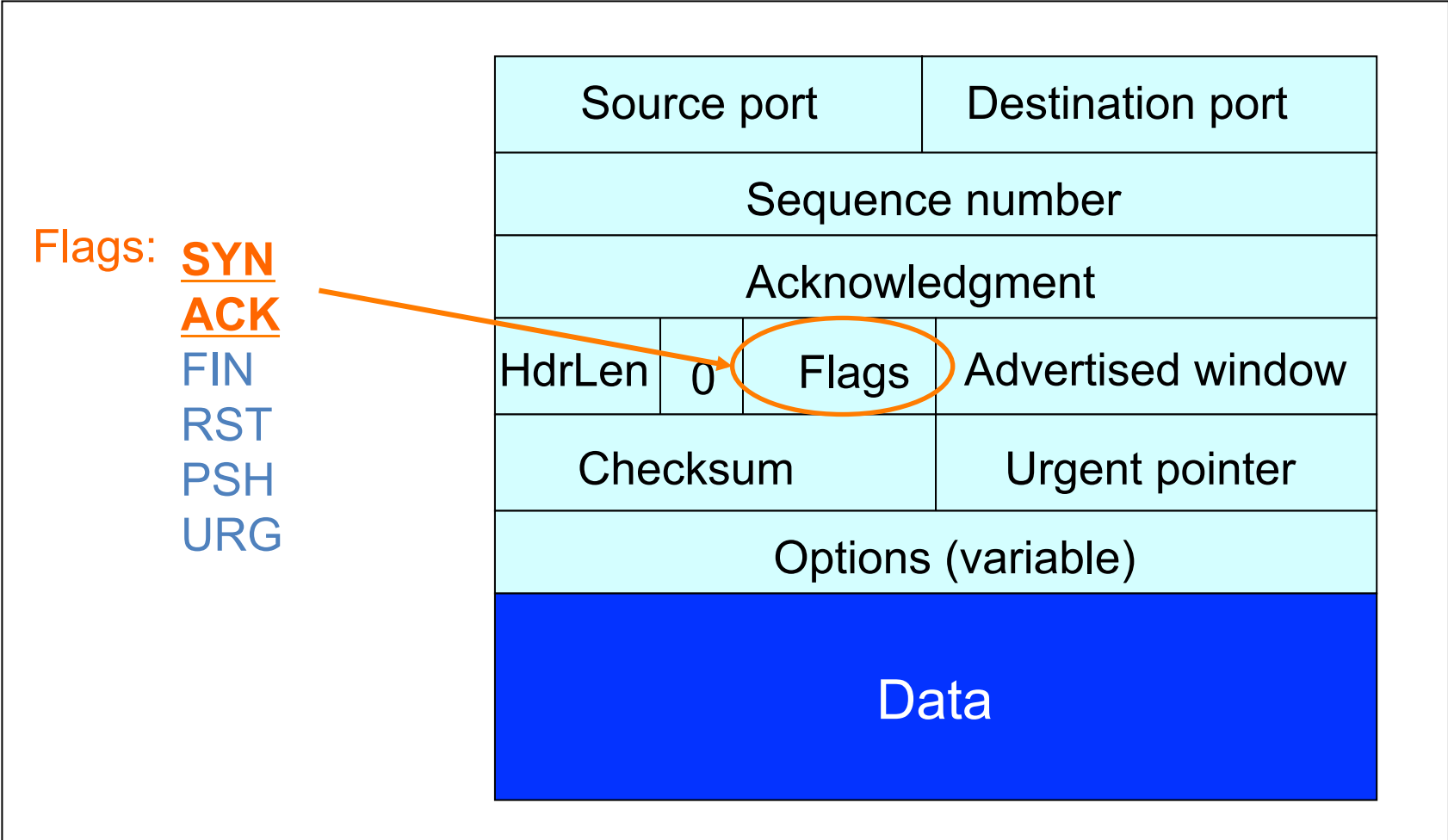

Step 1: A's Initial SYN Packet

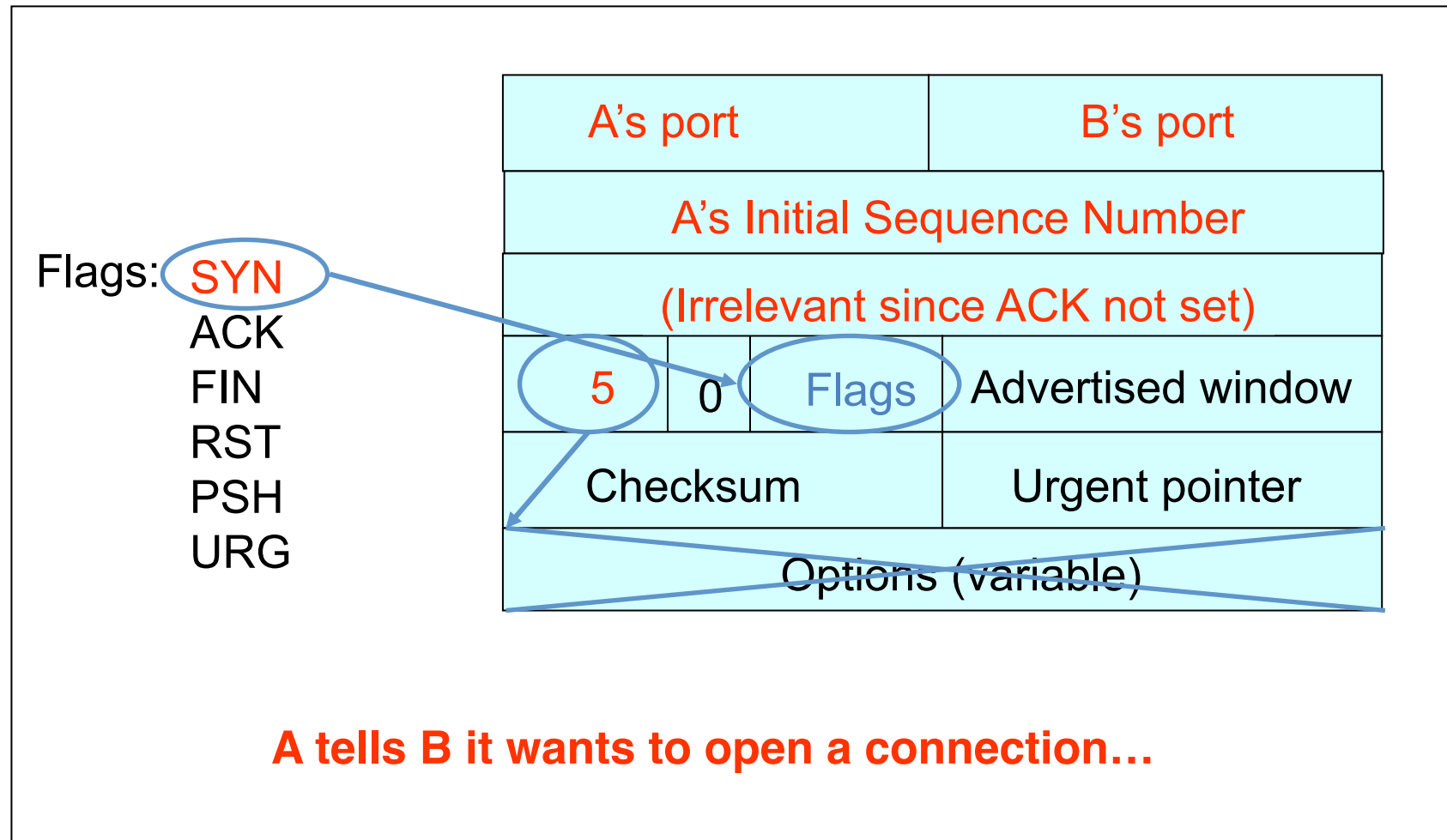

Step 2: B's SYN-ACK Packet

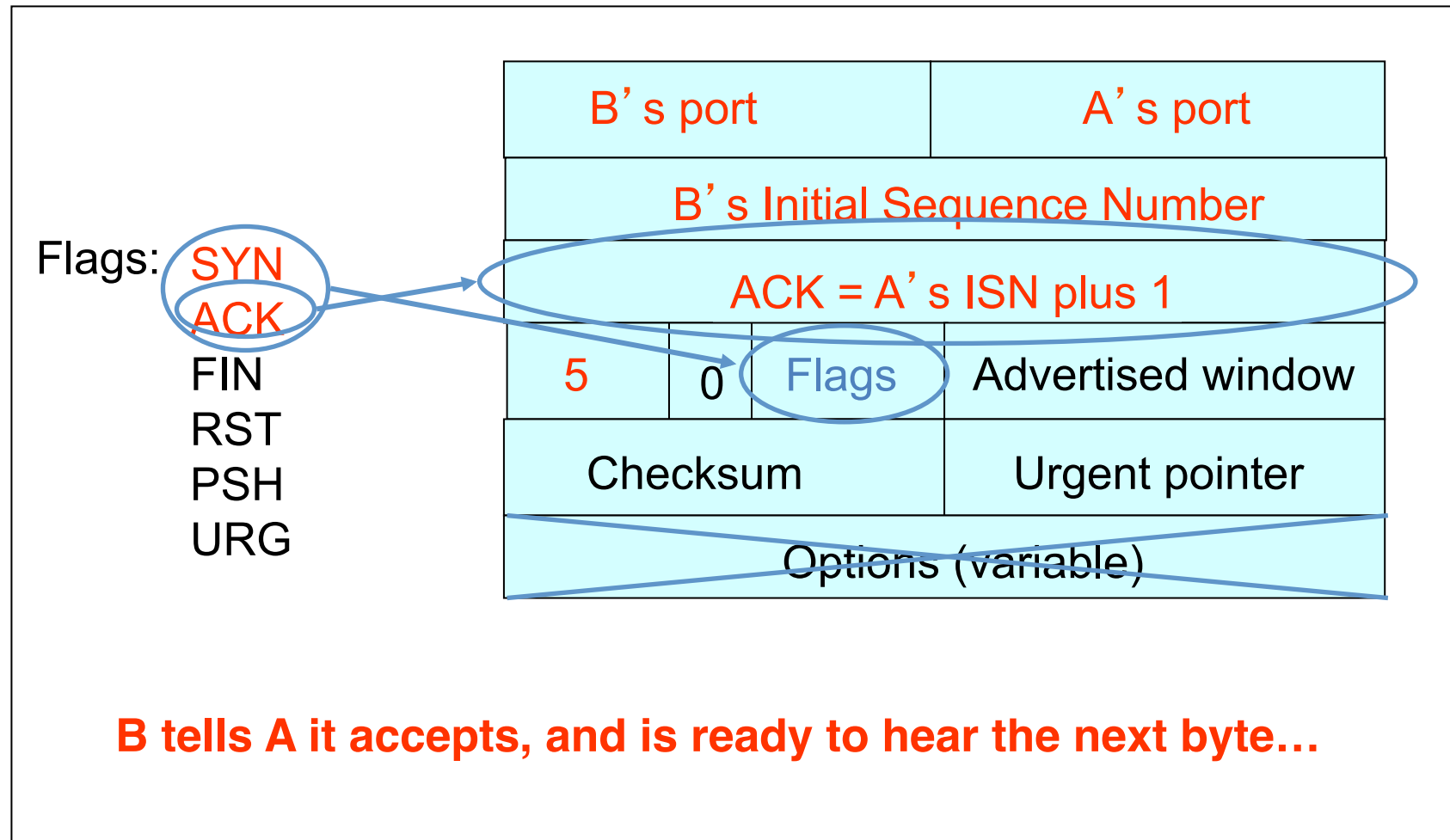

... upon receiving this packet, A can start sending data

Step 3: A's ACK of the SYN-ACK

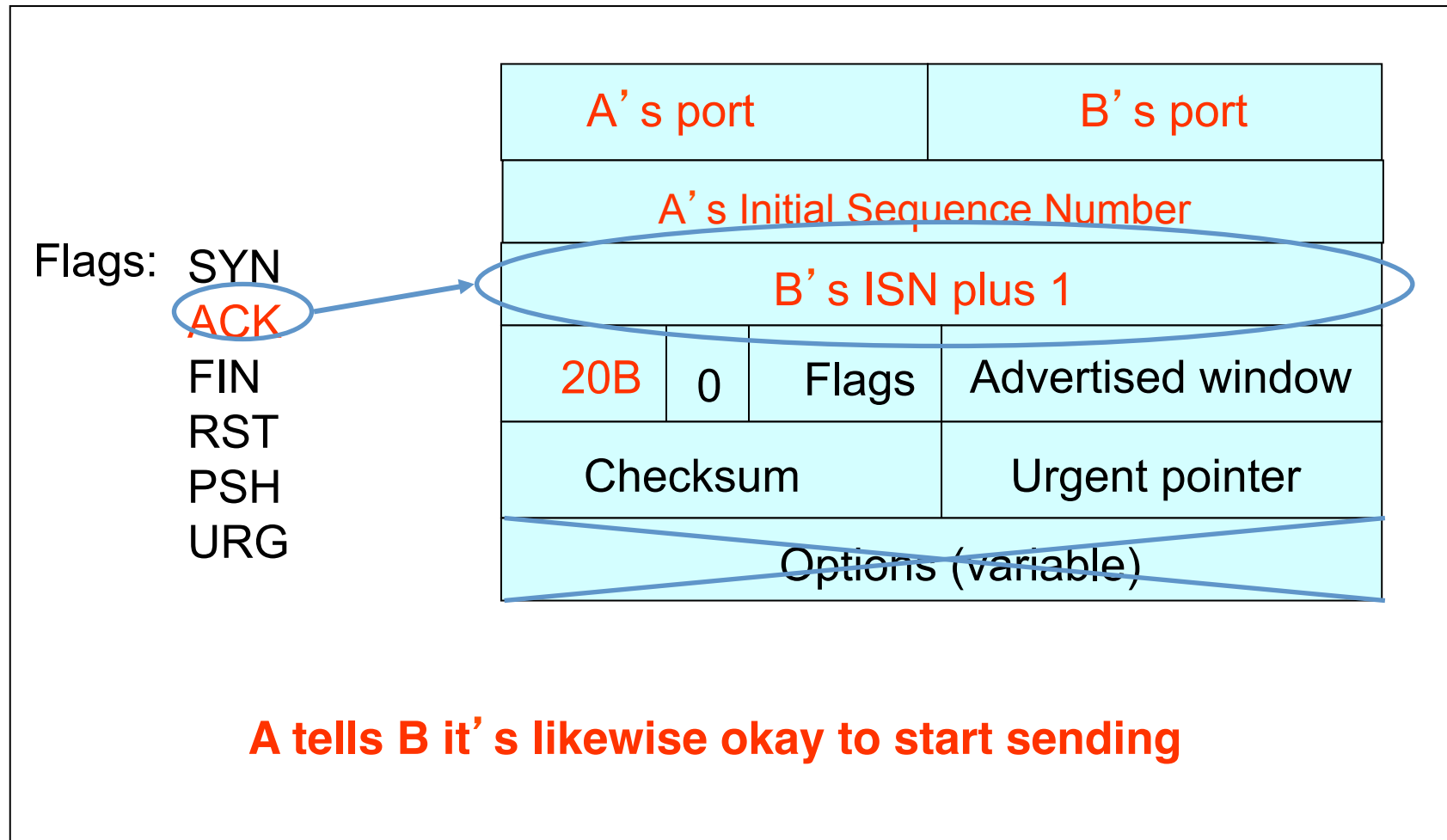

... upon receiving this packet, B can start sending data

Timing Diagram: 3-Way Handshaking

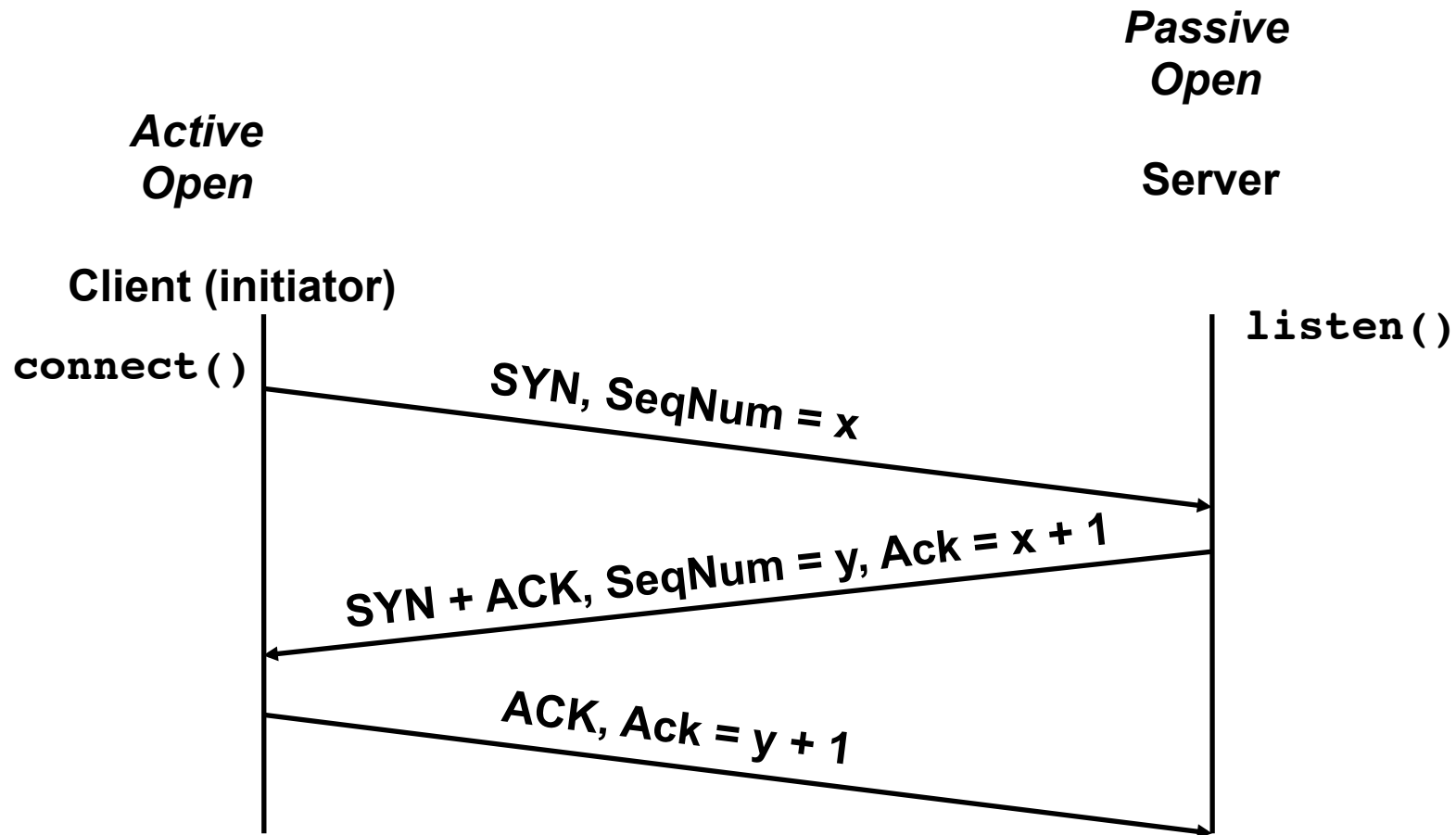

What if the SYN Packet Gets Lost?

- Suppose the SYN packet gets lost
 - Packet is lost inside the network, or:
 - Server **discards** the packet (e.g., it's too busy)
- Eventually, no SYN-ACK arrives
 - Sender sets a **timer** and **waits** for the SYN-ACK
 - ... and retransmits the SYN if needed
- How should the TCP sender set the timer?
 - Sender has **no idea** how far away the receiver is
 - Hard to guess a reasonable length of time to wait
 - **SHOULD** (RFCs 1122 & 2988) use default of **3 seconds**
 - Some implementations instead use 6 seconds

SYN Loss and Web Downloads

- User clicks on a hypertext link
 - Browser creates a socket and does a “connect”
 - The “connect” triggers the OS to transmit a SYN
- If the SYN is lost...
 - 3-6 seconds of delay: can be **very long**
 - User may become impatient
 - ... and click the hyperlink again, or click “reload”
- User triggers an “abort” of the “connect”
 - Browser creates a **new** socket and another “connect”
 - Essentially, forces a faster send of a new SYN packet!
 - Sometimes very effective, and the page comes quickly

Tearing Down the Connection

Normal Termination, One Side At A Time

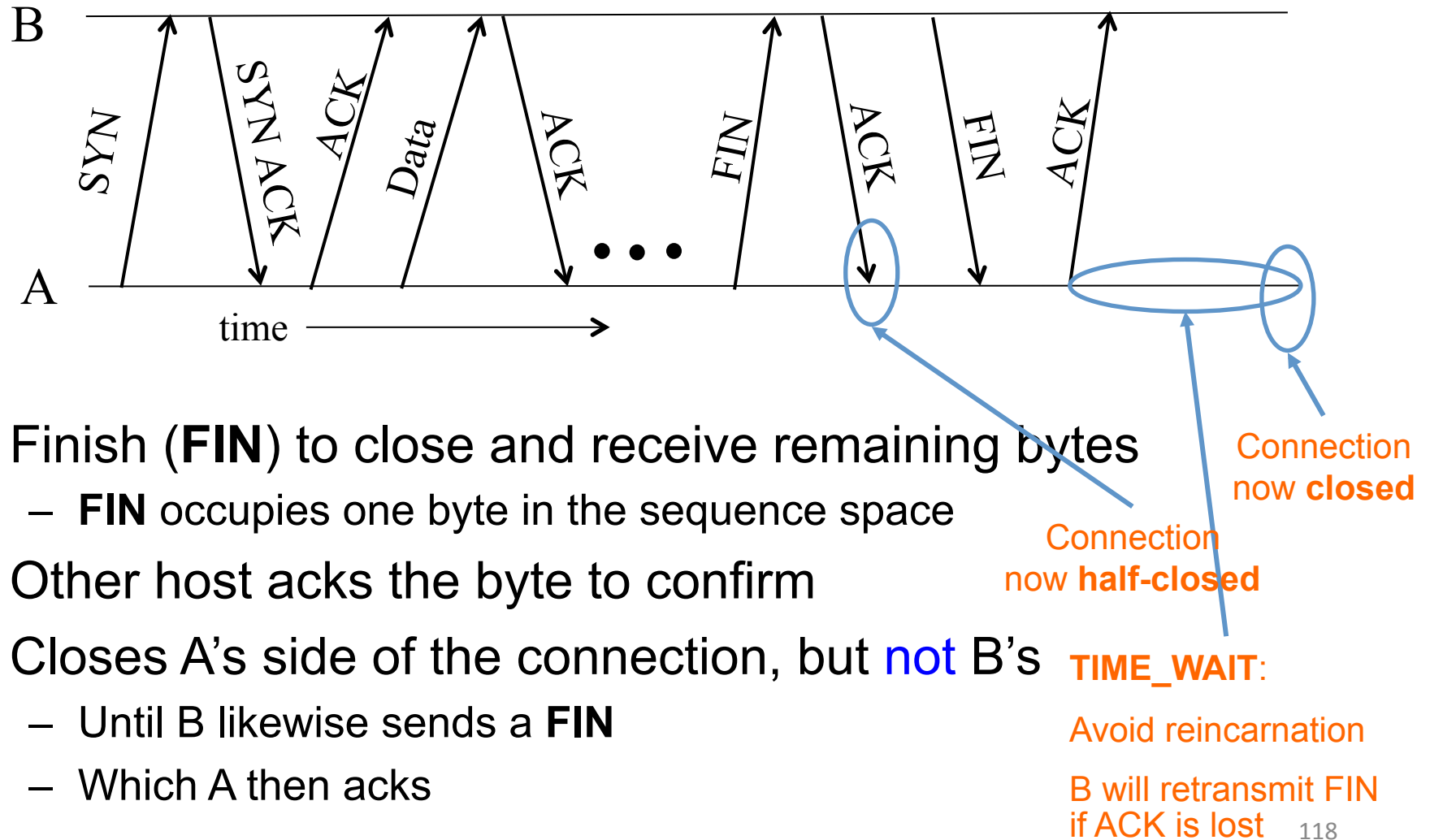

- Finish (**FIN**) to close and receive remaining bytes
 - **FIN** occupies one byte in the sequence space
- Other host acks the byte to confirm
- Closes A's side of the connection, but **not** B's
 - Until B likewise sends a **FIN**
 - Which A then acks

TIME_WAIT:

Avoid reincarnation

B will retransmit FIN if ACK is lost

Normal Termination, Both Together

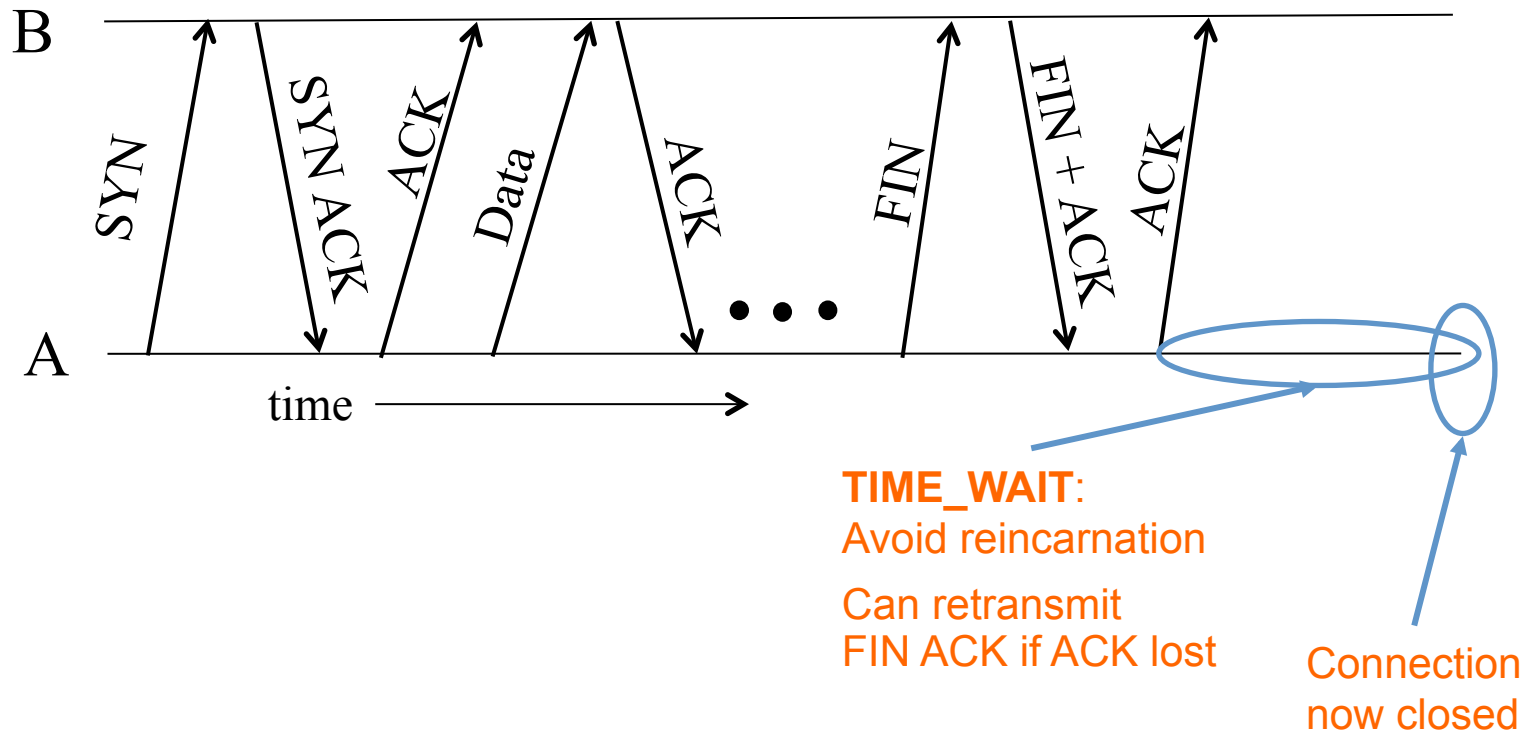

- Same as before, but B sets **FIN** with their ack of A's **FIN**

Abrupt Termination

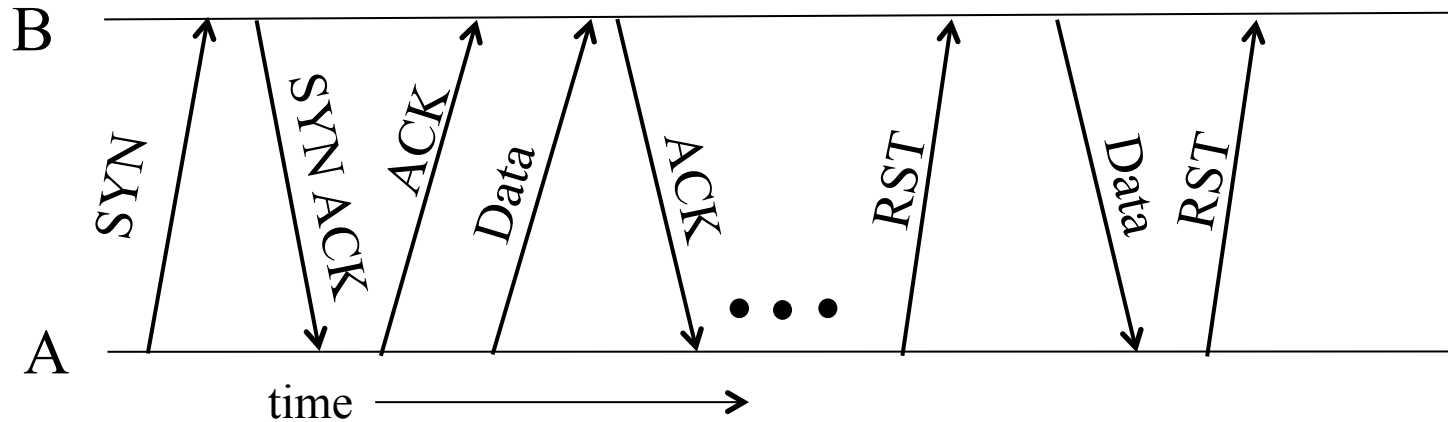

- A sends a RESET (**RST**) to B
 - E.g., because application process on A **crashed**
- **That's it**
 - B does **not** ack the **RST**
 - Thus, **RST** is **not** delivered **reliably**
 - And: any data in flight is **lost**
 - But: if B sends anything more, will elicit **another RST**

TCP Header

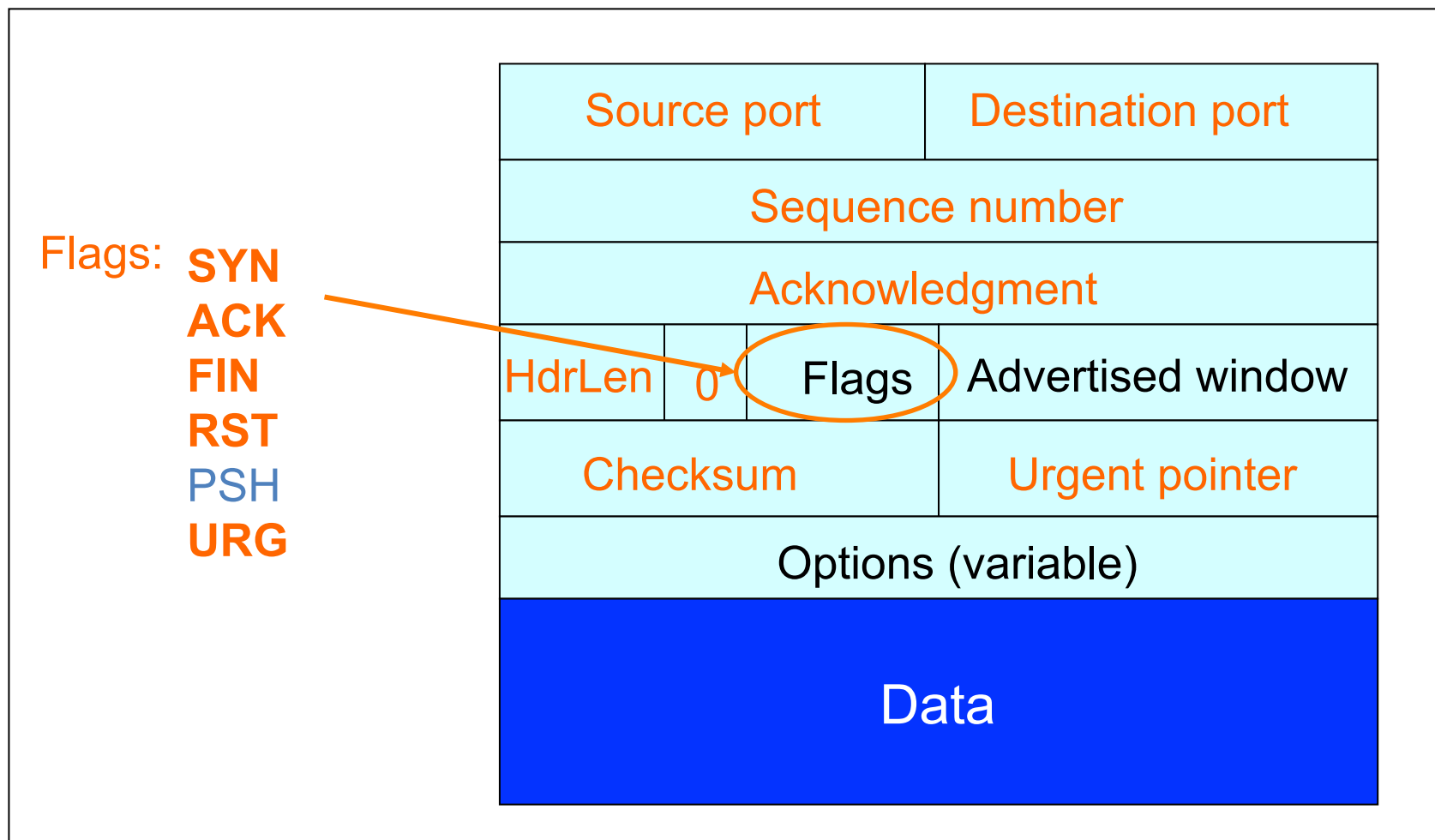

TCP State Transitions

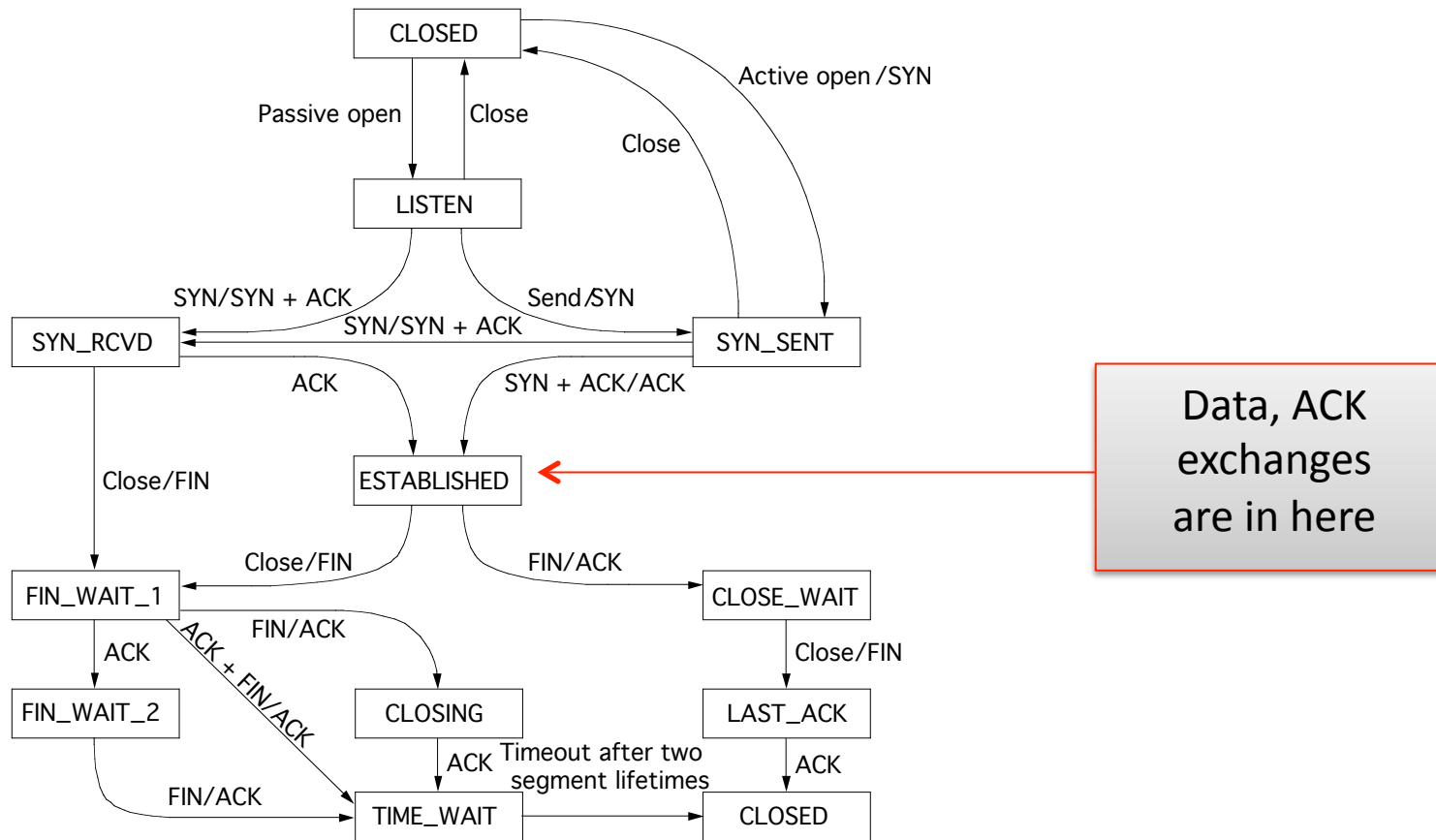

An Simpler View of the Client Side

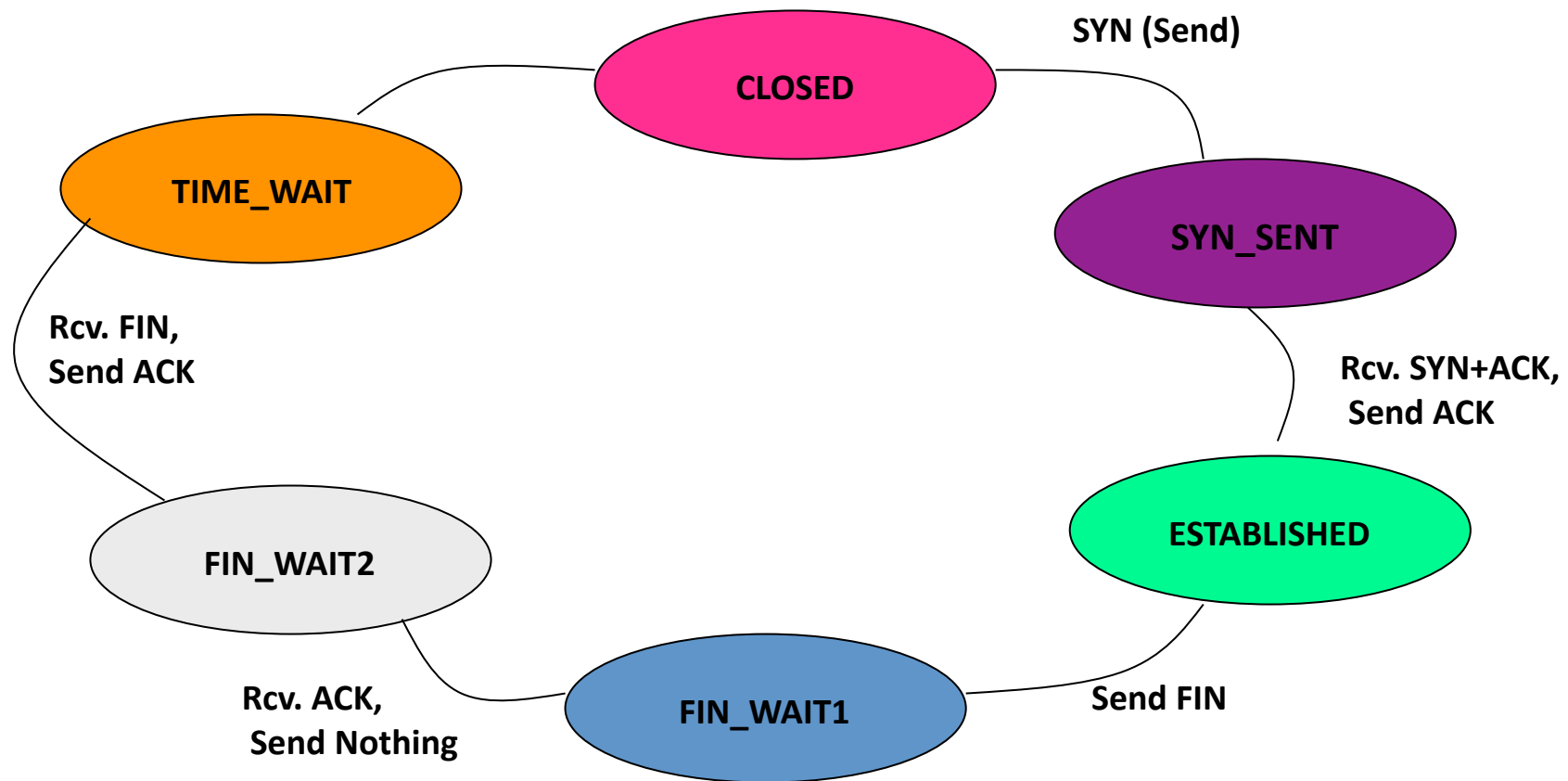

TCP Header

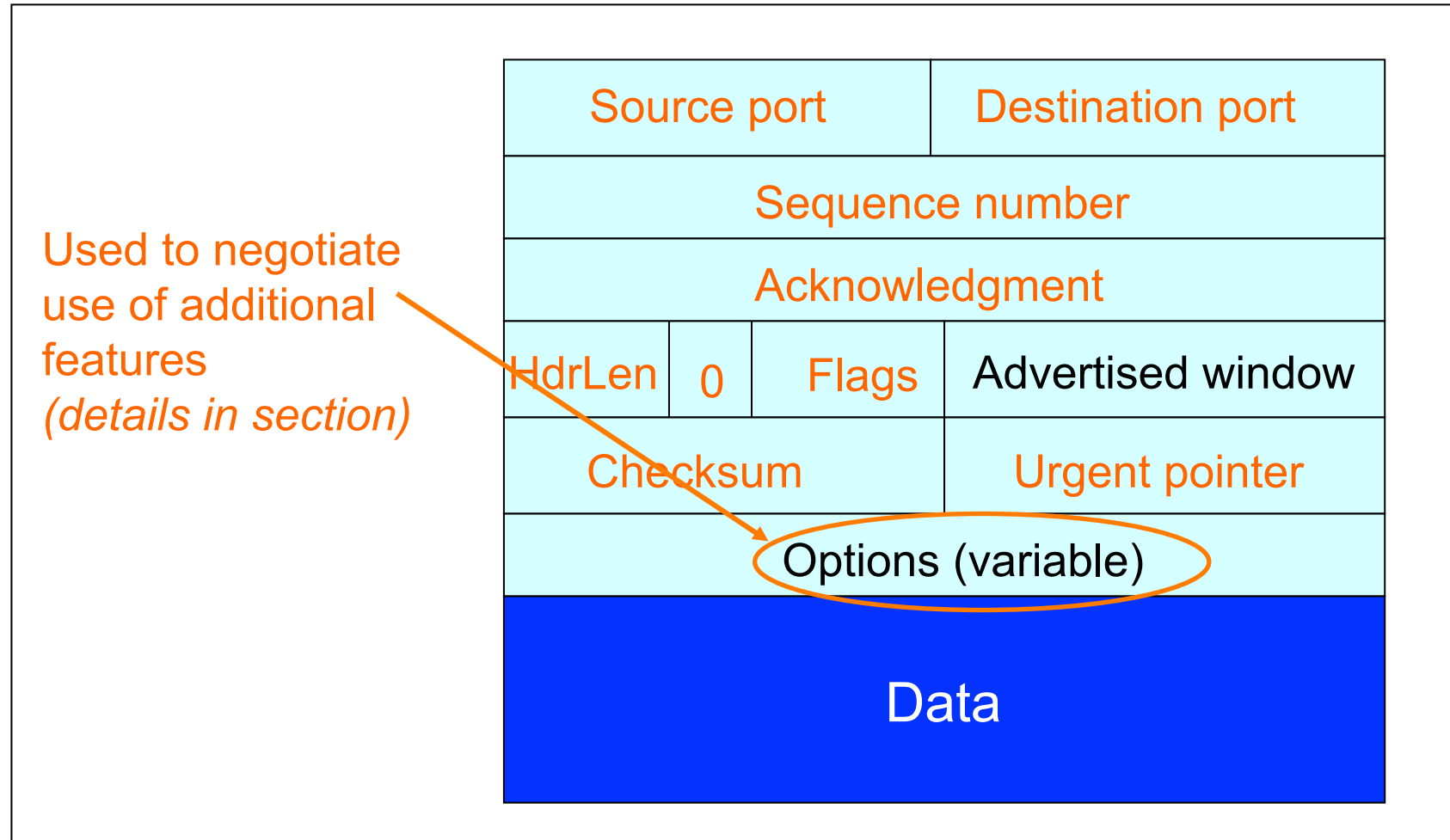

TCP Header

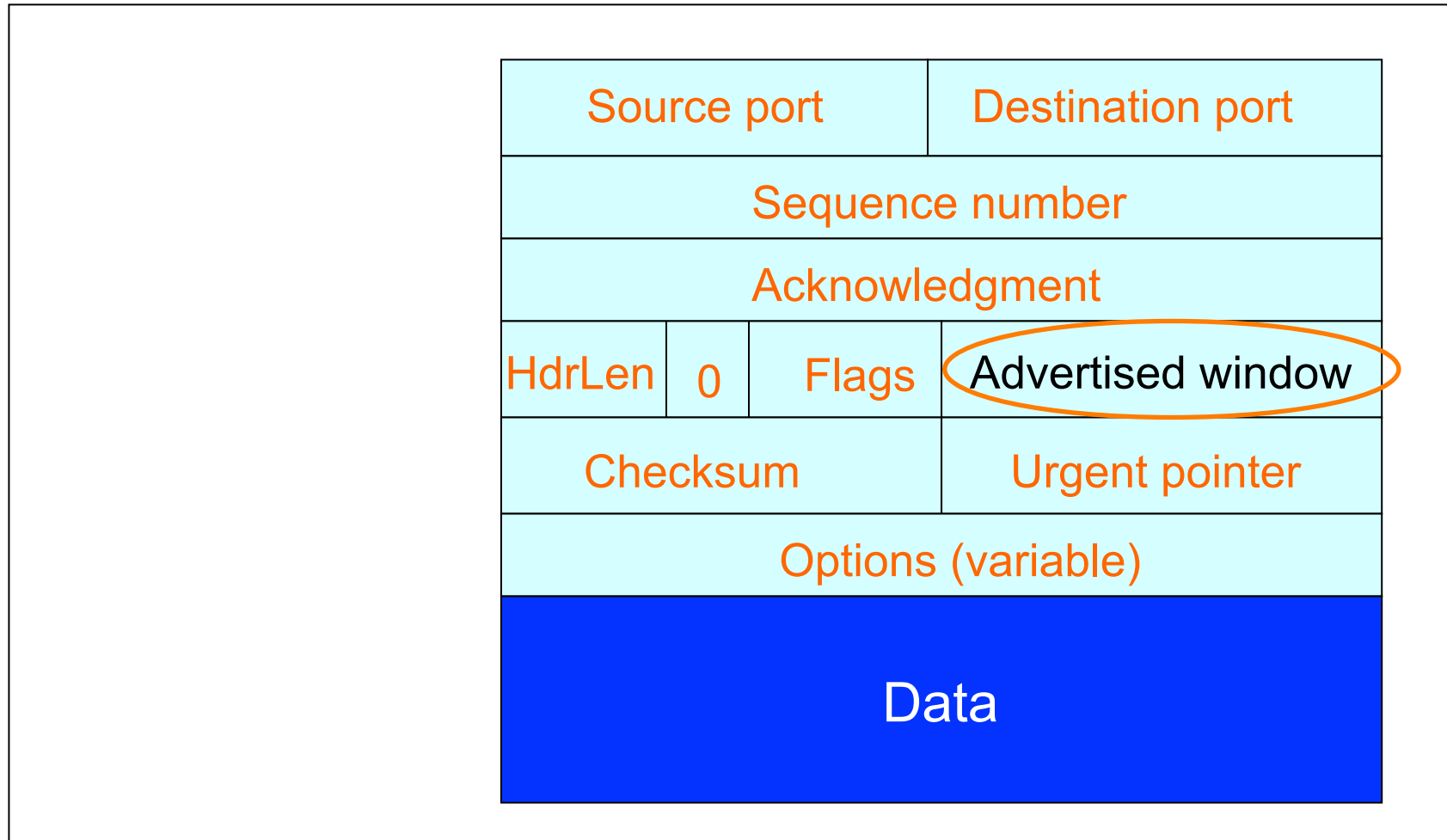

- What does TCP do?
 - ARQ windowing, set-up, tear-down
- Flow Control in TCP

Recap: Sliding Window (so far)

- Both sender & receiver maintain a **window**
- **Left edge** of window:
 - Sender: beginning of **unacknowledged** data
 - Receiver: beginning of **undelivered** data
- **Right edge**: Left edge + *constant*
 - constant only limited by buffer size in the transport layer

Sliding Window at Sender (so far)

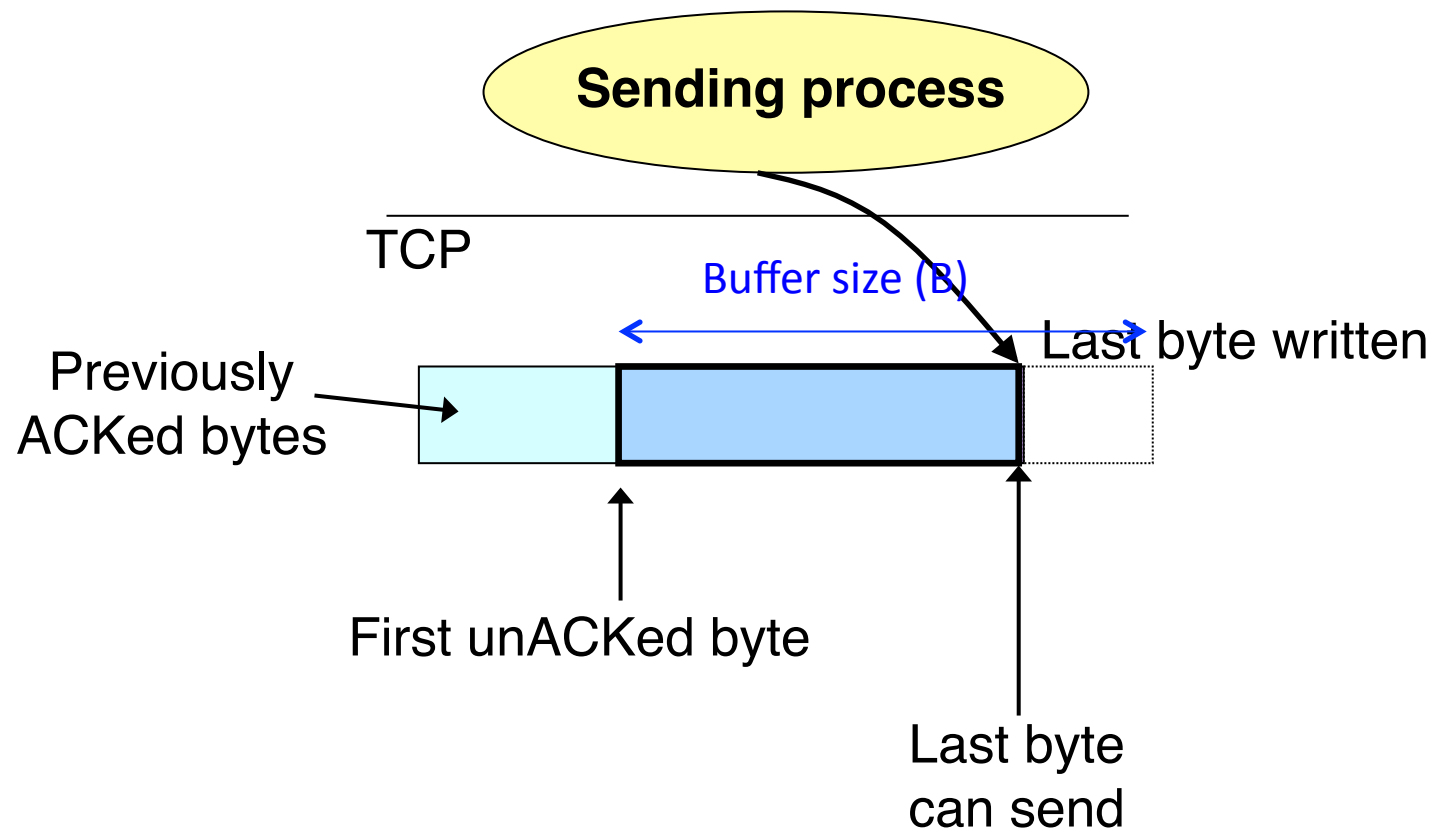

Sliding Window at Receiver (so far)

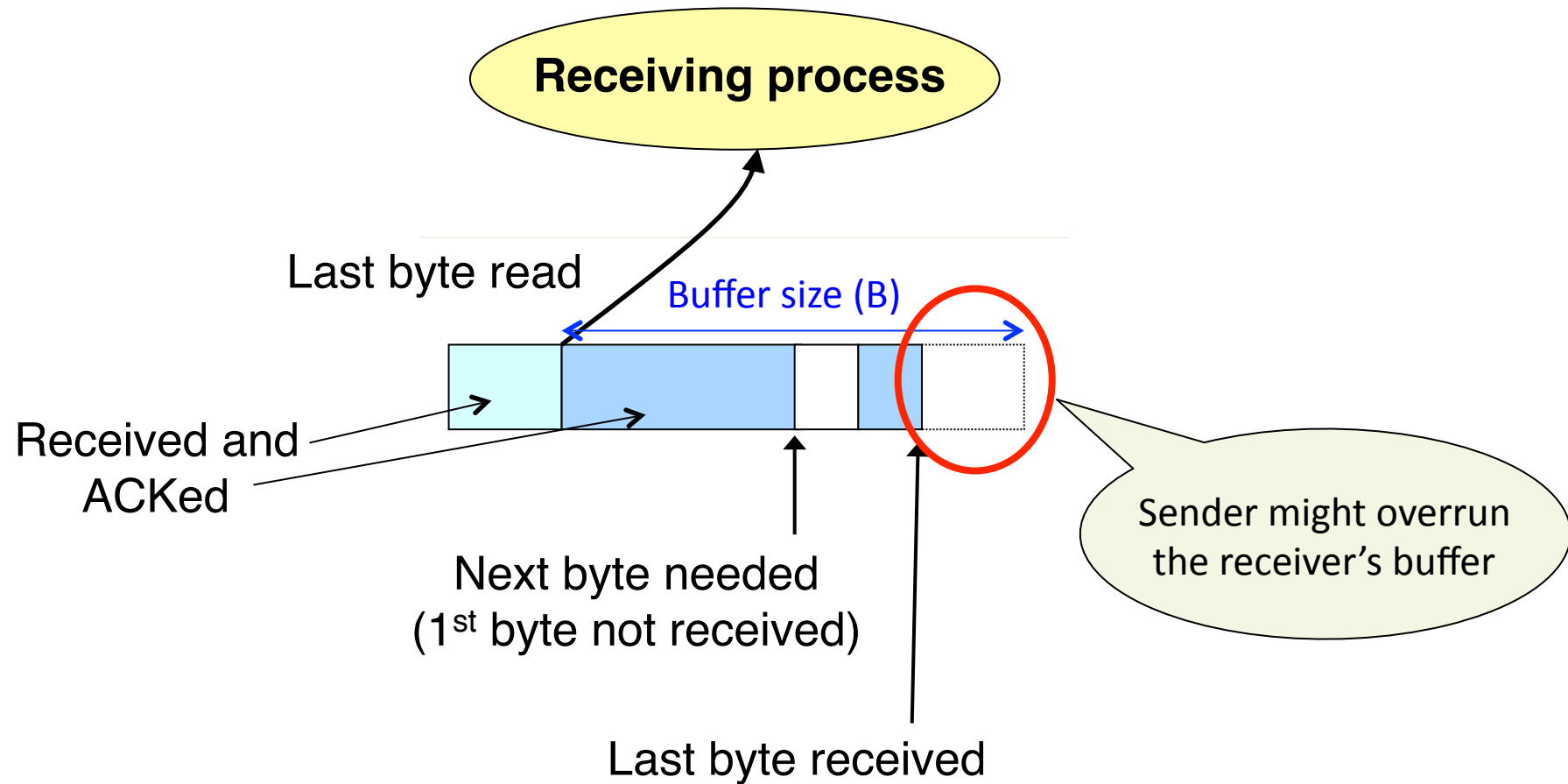

Solution: Advertised Window (Flow Control)

- Receiver uses an “Advertised Window” (W) to prevent sender from overflowing its window
 - Receiver indicates value of W in ACKs
 - Sender limits number of bytes it can have in flight $\leq W$

Sliding Window at Receiver

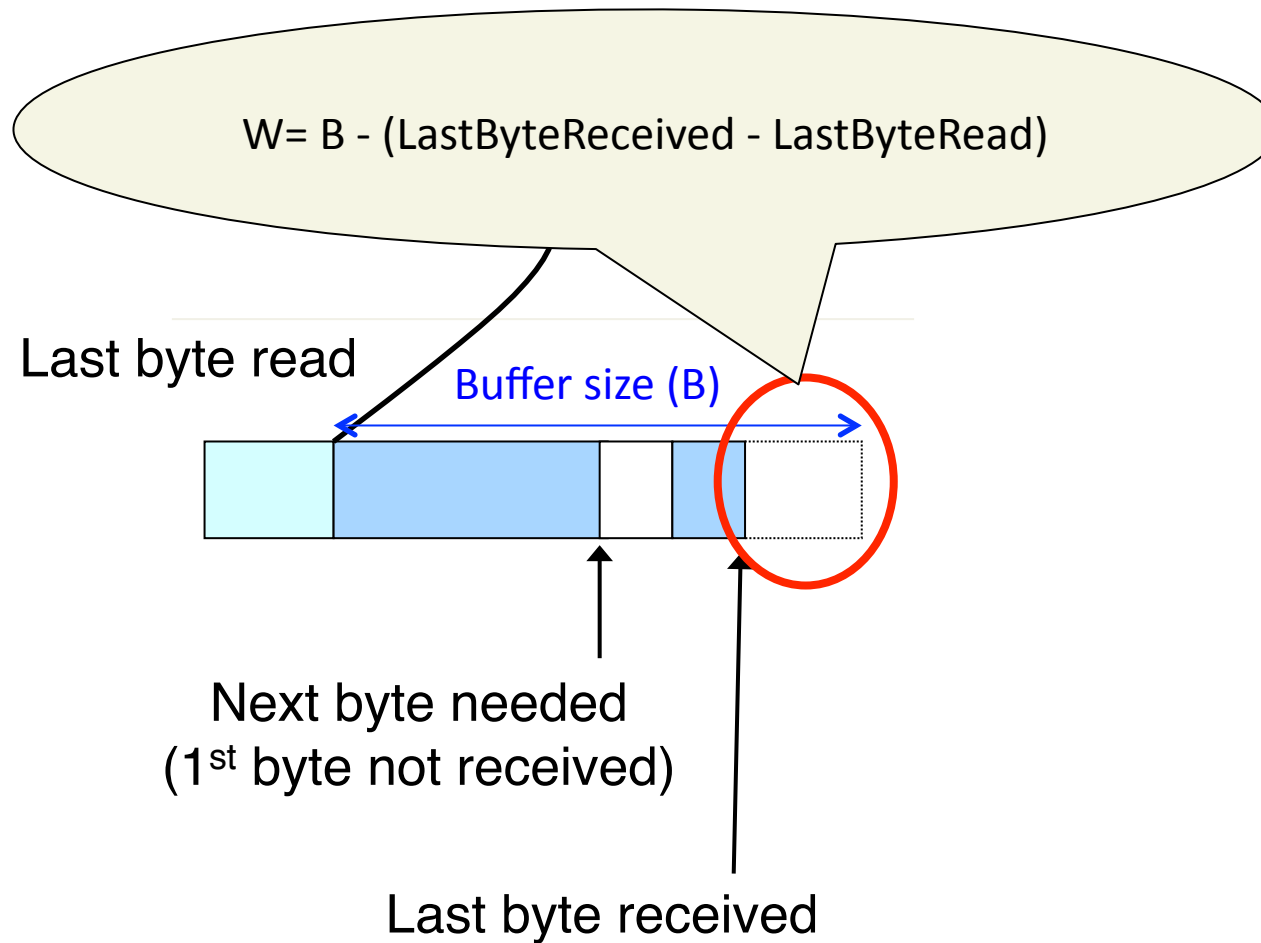

Sliding Window at Sender (so far)

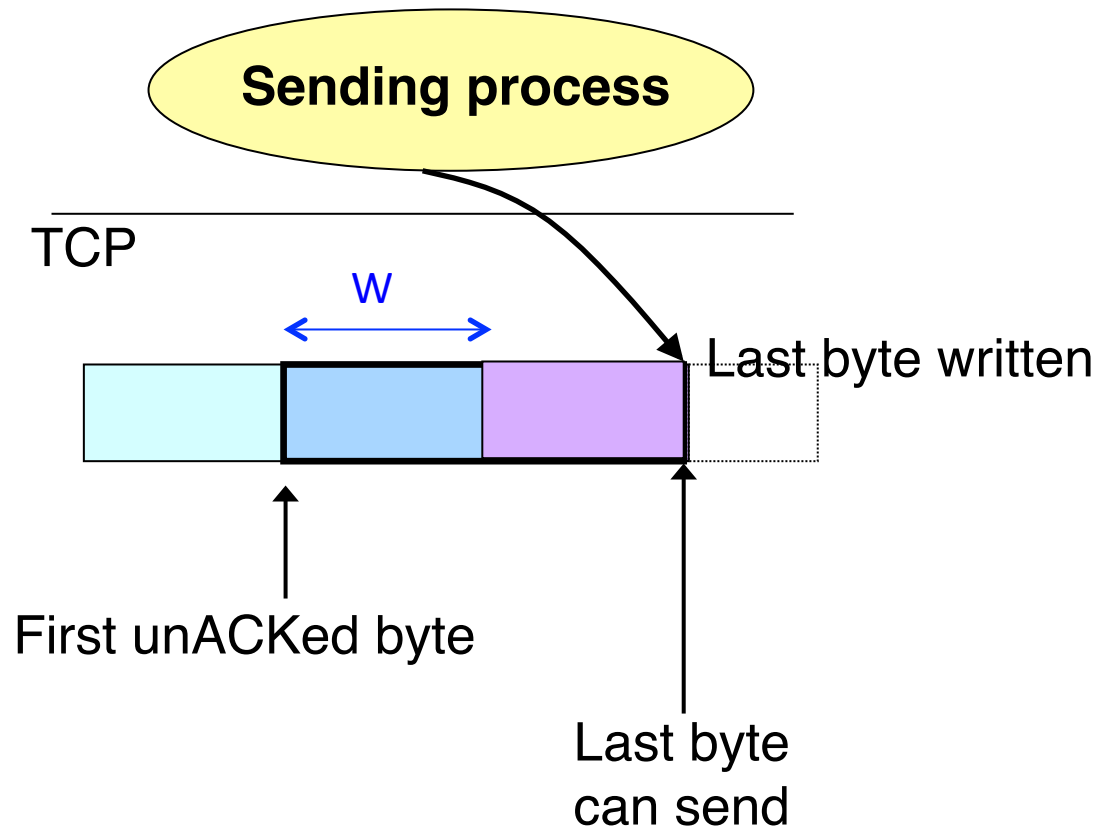

Sliding Window w/ Flow Control

- Sender: window **advances** when new data ack'd
- Receiver: window advances as receiving process **consumes** data
- Receiver **advertises** to the sender where the receiver window currently ends (“righthand edge”)
 - Sender agrees not to exceed this amount

Advertised Window Limits Rate

- Sender can send no faster than W/RTT bytes/sec
- Receiver only advertises more space when it has consumed old arriving data
- In original TCP design, that was the **sole** protocol mechanism controlling sender's rate
- What's missing?

TCP

- The concepts underlying TCP are simple
 - acknowledgments (feedback)
 - timers
 - sliding windows
 - buffer management
 - sequence numbers

TCP

- The concepts underlying TCP are simple
- But tricky in the details
 - How do we set timers?
 - What is the seqno for an ACK-only packet?
 - What happens if advertised window = 0?
 - What if the advertised window is $\frac{1}{2}$ an MSS?
 - Should receiver acknowledge packets right away?
 - What if the application generates data in units of 0.1 MSS?
 - What happens if I get a duplicate SYN? Or a RST while I'm in FIN_WAIT, *etc., etc., etc.*

TCP

- The concepts underlying TCP are simple
- But tricky in the details
- **Do the details matter?**

Sizing Windows for Congestion Control

- What are the problems?
- How might we address them?

- What does TCP do?
 - ARQ windowing, set-up, tear-down
- Flow Control in TCP
- Congestion Control in TCP

We have seen:

- **Flow control**: adjusting the sending rate to keep from overwhelming a slow *receiver*

Now lets attend...

- **Congestion control**: adjusting the sending rate to keep from overloading the *network*

Statistical Multiplexing → Congestion

- If two packets arrive at the same time
 - A router can only transmit one
 - ... and either buffers or drops the other
- If many packets arrive in a short period of time
 - The router cannot keep up with the arriving traffic
 - ... **delays** traffic, and the buffer may eventually **overflow**
- Internet traffic is **bursty**

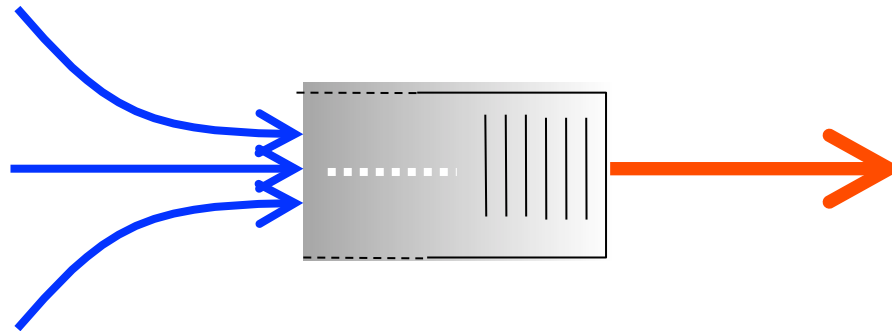

Congestion is undesirable

Typical **queuing system** with bursty arrivals

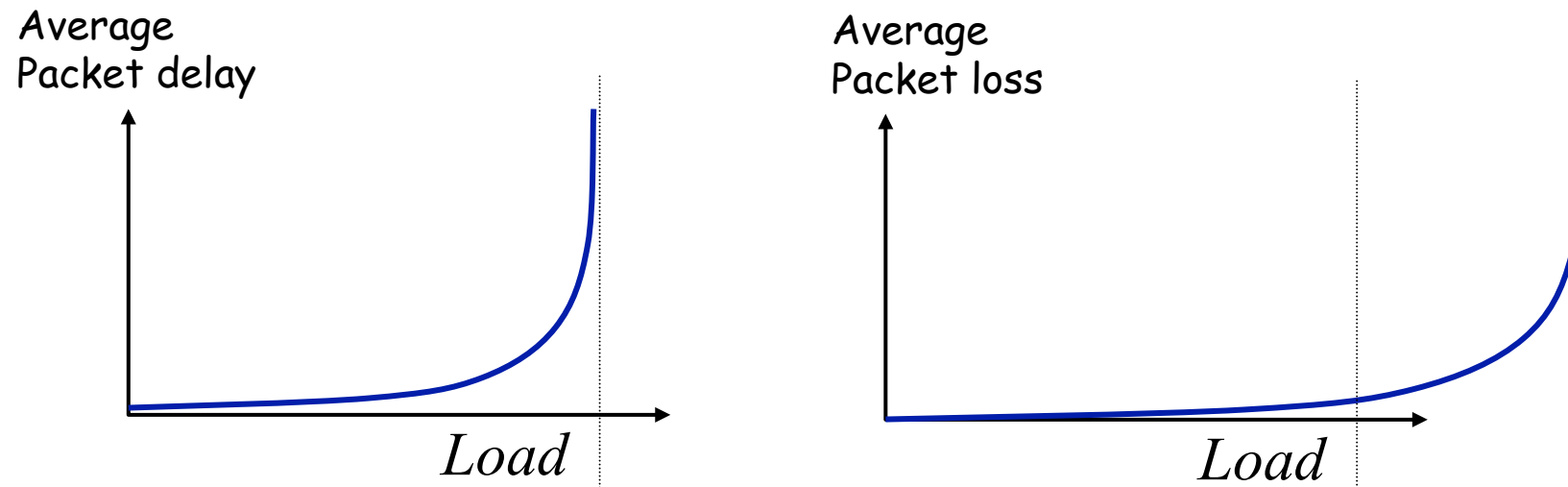

Must balance utilization versus delay and loss

Who Takes Care of Congestion?

- Network? End hosts? Both?
- TCP's approach:
 - **End hosts** adjust sending rate
 - Based on **implicit feedback** from network
- Not the only approach
 - A consequence of history rather than planning

Some History: TCP in the 1980s

- Sending rate only limited by flow control
 - Packet drops → senders (repeatedly!) retransmit a full window's worth of packets
- Led to “congestion collapse” starting Oct. 1986
 - Throughput on the NSF network dropped from 32Kbits/s to 40bits/sec
- “Fixed” by Van Jacobson's development of TCP's congestion control (CC) algorithms

Jacobson's Approach

- Extend TCP's existing window-based protocol but adapt the window size in response to congestion
 - required no upgrades to routers or applications!
 - patch of a few lines of code to TCP implementations
- A pragmatic and effective solution
 - but many other approaches exist
- Extensively improved on since
 - topic now sees less activity in ISP contexts
 - but is making a comeback in datacenter environments

Three Issues to Consider

- Discovering the available (bottleneck) bandwidth
- Adjusting to variations in bandwidth
- Sharing bandwidth between flows

Abstract View

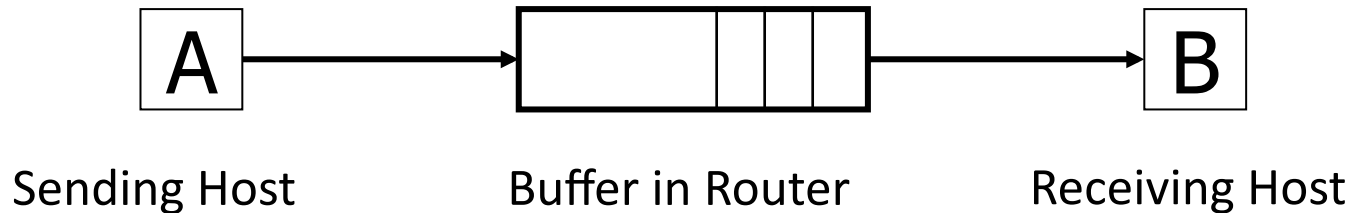

- Ignore internal structure of router and model it as having a single queue for a particular input-output pair

Discovering available bandwidth

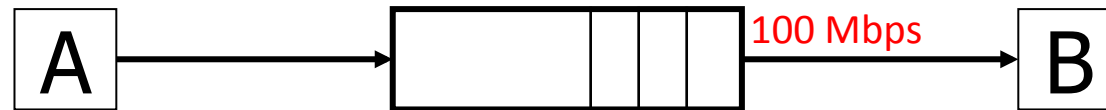

- Pick sending rate to match bottleneck bandwidth
 - Without any *a priori* knowledge
 - Could be gigabit link, could be a modem

Adjusting to variations in bandwidth



- Adjust rate to match **instantaneous** bandwidth
 - Assuming you have rough idea of bandwidth

Multiple flows and sharing bandwidth

Two Issues:

- Adjust total sending rate to match bandwidth
- Allocation of bandwidth between flows

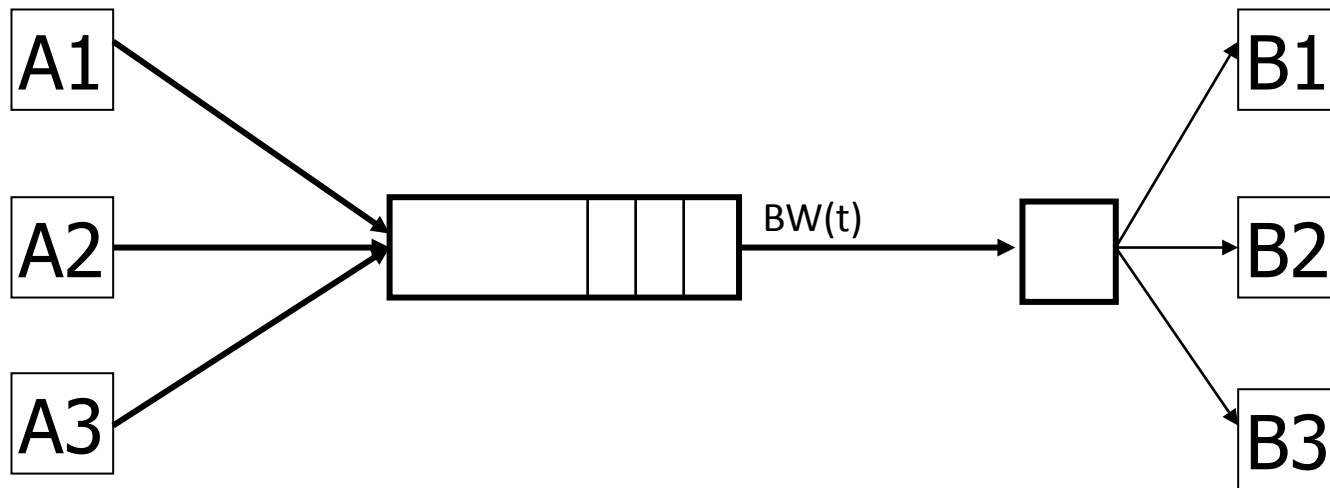

Reality

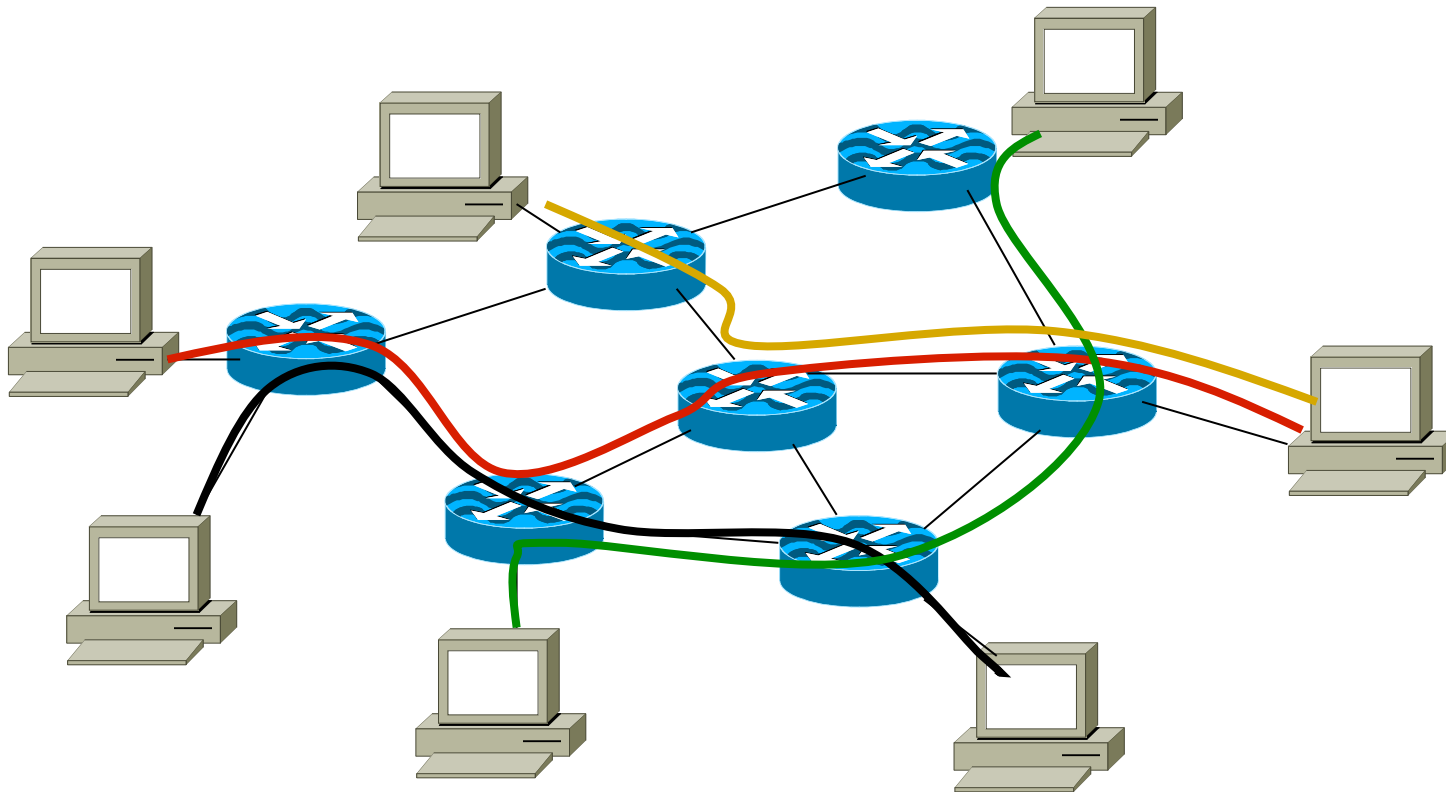

Congestion control is a resource allocation problem involving many flows, many links, and complicated global dynamics

View from a single flow

- Knee – point after which
 - Throughput increases slowly
 - Delay increases fast
- Cliff – point after which
 - Throughput starts to drop to zero (congestion collapse)
 - Delay approaches infinity

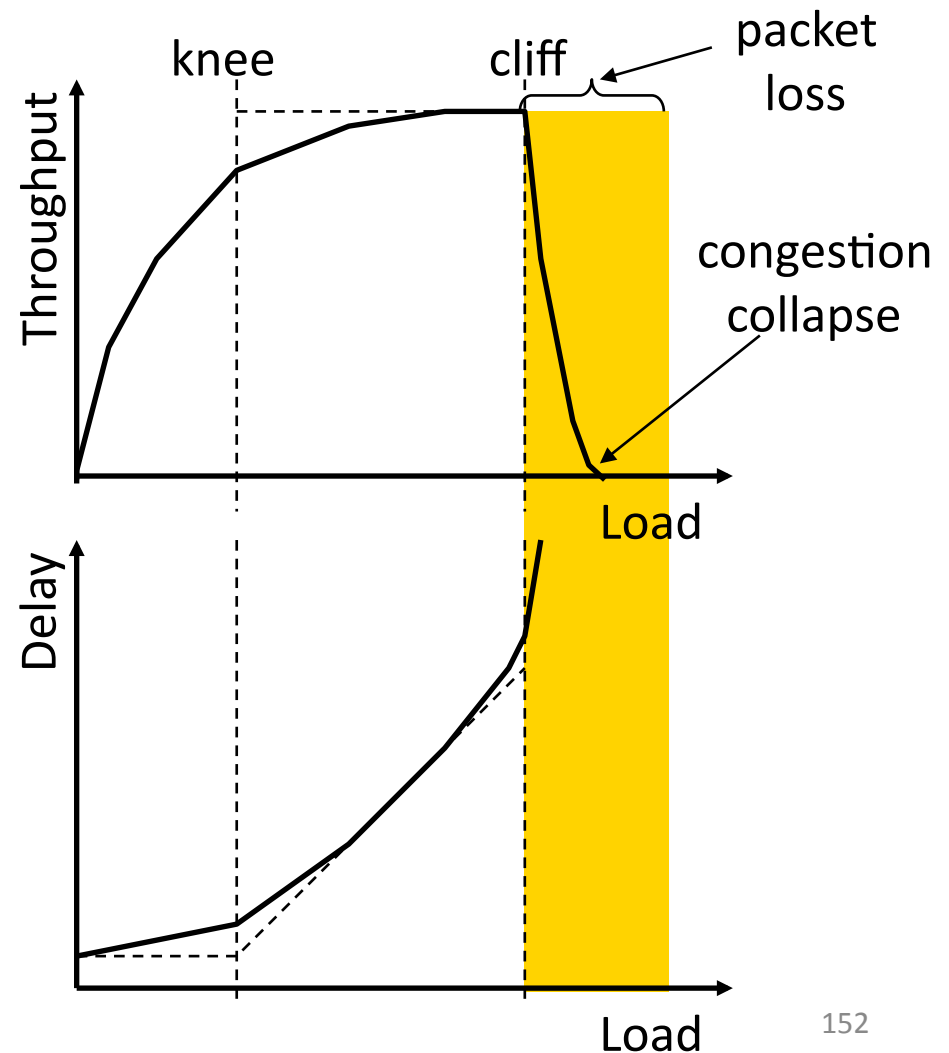

General Approaches

- (0) Send without care
 - Many packet drops

General Approaches

(0) Send without care

(1) Reservations

- Pre-arrange bandwidth allocations
- Requires negotiation before sending packets
- Low utilization

General Approaches

(0) Send without care

(1) Reservations

(2) Pricing

- Don't drop packets for the high-bidders
- Requires payment model

General Approaches

(0) Send without care

(1) Reservations

(2) Pricing

(3) Dynamic Adjustment

- Hosts probe network; infer level of congestion; adjust
- Network reports congestion level to hosts; hosts adjust
- Combinations of the above
- Simple to implement but suboptimal, messy dynamics

General Approaches

- (0) Send without care
- (1) Reservations
- (2) Pricing
- (3) Dynamic Adjustment

All three techniques have their place

- *Generality* of dynamic adjustment has proven powerful
- Doesn't presume business model, traffic characteristics, application requirements; does assume good citizenship

TCP's Approach in a Nutshell

- TCP connection has window
 - Controls number of packets in flight
- Sending rate: $\sim \text{Window} / \text{RTT}$
- Vary window size to control sending rate

All These Windows...

- Congestion Window: **CWND**
 - How many bytes can be sent without overflowing routers
 - Computed by the sender using congestion control algorithm
- Flow control window: **AdvertisedWindow (RWND)**
 - How many bytes can be sent without overflowing receiver's buffers
 - Determined by the receiver and reported to the sender
- Sender-side window = **minimum**{**CWND**,**RWND**}
 - Assume for this lecture that $RWND \gg CWND$

Note

- This lecture will talk about CWND in units of MSS
 - (Recall MSS: Maximum Segment Size, the amount of payload data in a TCP packet)
 - This is only for pedagogical purposes
- Keep in mind that real implementations maintain CWND in bytes

Two Basic Questions

- How does the sender detect congestion?
- How does the sender adjust its sending rate?
 - To address three issues
 - Finding available bottleneck bandwidth
 - Adjusting to bandwidth variations
 - Sharing bandwidth

Detecting Congestion

- Packet delays
 - Tricky: noisy signal (delay often varies considerably)
- Router tell endhosts they're congested
- Packet loss
 - Fail-safe signal that TCP already has to detect
 - Complication: non-congestive loss (checksum errors)
- Two indicators of packet loss
 - No ACK after certain time interval: **timeout**
 - Multiple **duplicate ACKs**

Not All Losses the Same

- Duplicate ACKs: isolated loss
 - Still getting ACKs
- Timeout: much more serious
 - Not enough dupacks
 - Must have suffered several losses
- Will adjust rate differently for each case

Rate Adjustment

- Basic structure:
 - Upon receipt of ACK (of new data): increase rate
 - Upon detection of loss: decrease rate
- How we increase/decrease the rate depends on the phase of congestion control we're in:
 - Discovering available bottleneck bandwidth vs.
 - Adjusting to bandwidth variations

Bandwidth Discovery with Slow Start

- Goal: estimate available bandwidth
 - start slow (for safety)
 - but ramp up quickly (for efficiency)
- Consider
 - RTT = 100ms, MSS=1000bytes
 - Window size to fill 1Mbps of BW = 12.5 packets
 - Window size to fill 1Gbps = 12,500 packets
 - Either is possible!

“Slow Start” Phase

- Sender starts at a slow rate but increases **exponentially** until first loss
- Start with a small congestion window
 - Initially, $CWND = 1$
 - So, initial sending rate is MSS/RTT
- Double the $CWND$ for each RTT with no loss

Slow Start in Action

- For each RTT: double CWND
- Simpler implementation: for each ACK, CWND += 1

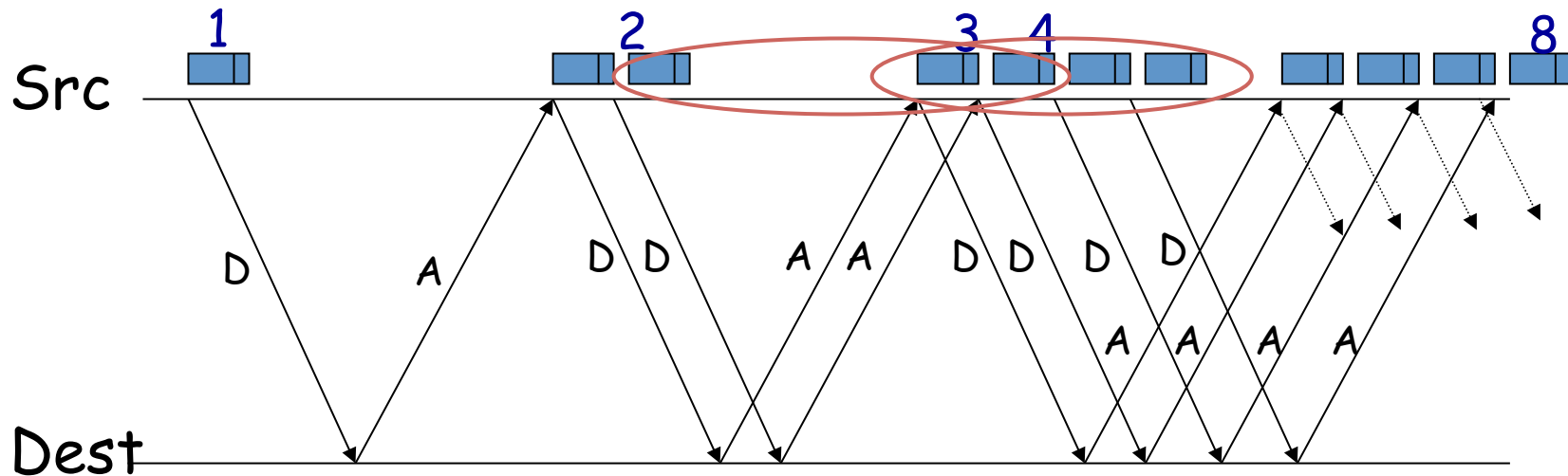

Adjusting to Varying Bandwidth

- Slow start gave an estimate of available bandwidth
- Now, want to track variations in this available bandwidth, oscillating around its current value
 - Repeated probing (rate increase) and backoff (rate decrease)
- TCP uses: “Additive Increase Multiplicative Decrease” (AIMD)
 - We’ll see why shortly...

AIMD

- Additive increase
 - Window grows by one MSS for every RTT with no loss
 - For each successful RTT, $CWND = CWND + 1$
 - Simple implementation:
 - for each ACK, $CWND = CWND + 1/CWND$
- Multiplicative decrease
 - On loss of packet, divide congestion window in **half**
 - On loss, $CWND = CWND/2$

Leads to the TCP “Sawtooth”

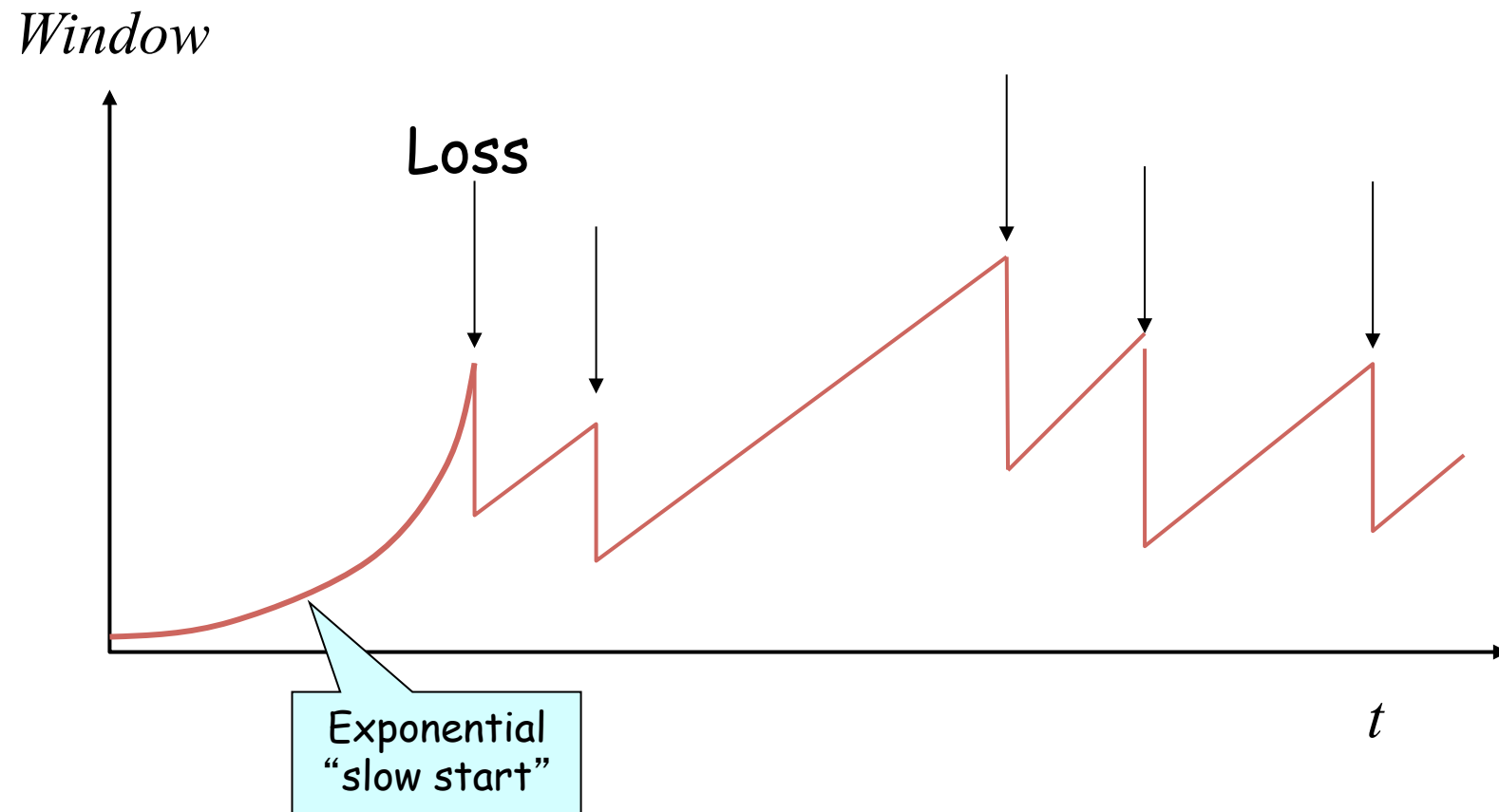

Slow-Start vs. AIMD

- When does a sender stop Slow-Start and start Additive Increase?
- Introduce a “slow start threshold” (**ssthresh**)
 - Initialized to a large value
 - On timeout, $ssthresh = CWND/2$
- When $CWND = ssthresh$, sender switches from slow-start to AIMD-style increase

- What does TCP do?
 - ARQ windowing, set-up, tear-down
- Flow Control in TCP
- Congestion Control in TCP
 - AIMD

Why AIMD?

Recall: Three Issues

- Discovering the available (bottleneck) bandwidth
 - Slow Start
- Adjusting to variations in bandwidth
 - AIMD
- Sharing bandwidth between flows

Goals for bandwidth sharing

- Efficiency: High utilization of link bandwidth
- Fairness: Each flow gets equal share

Why AIMD?

- Some rate adjustment options: Every RTT, we can
 - Multiplicative increase or decrease: $CWND \rightarrow a * CWND$
 - Additive increase or decrease: $CWND \rightarrow CWND + b$
- Four alternatives:
 - AIAD: gentle increase, gentle decrease
 - AIMD: gentle increase, drastic decrease
 - MIAD: drastic increase, gentle decrease
 - MIMD: drastic increase and decrease

Simple Model of Congestion Control

- Two users
 - rates x_1 and x_2
- Congestion when $x_1 + x_2 > 1$
- Unused capacity when $x_1 + x_2 < 1$
- Fair when $x_1 = x_2$

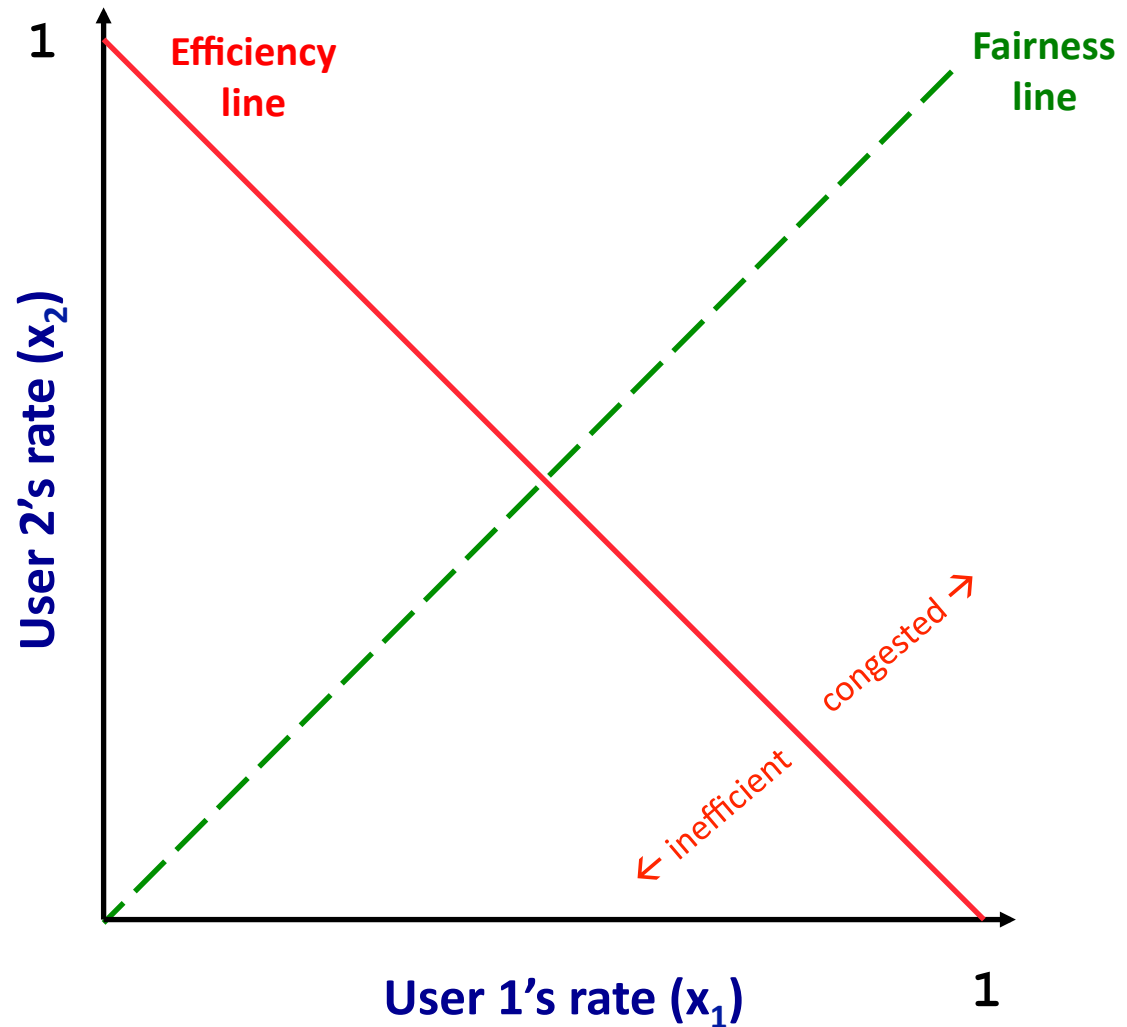

Example

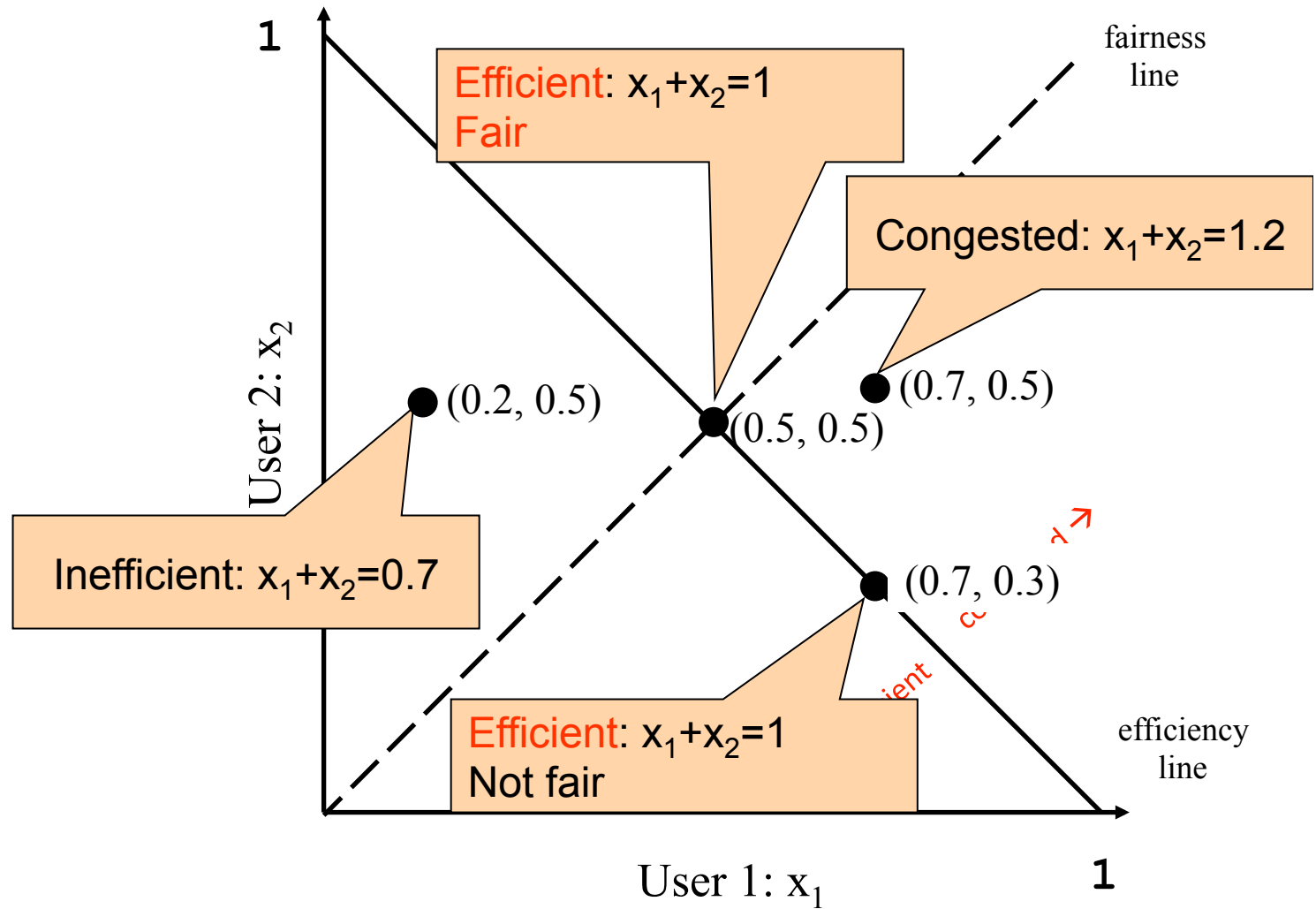

AIAD

- Increase: $x + a_I$
- Decrease: $x - a_D$
- Does not converge to fairness

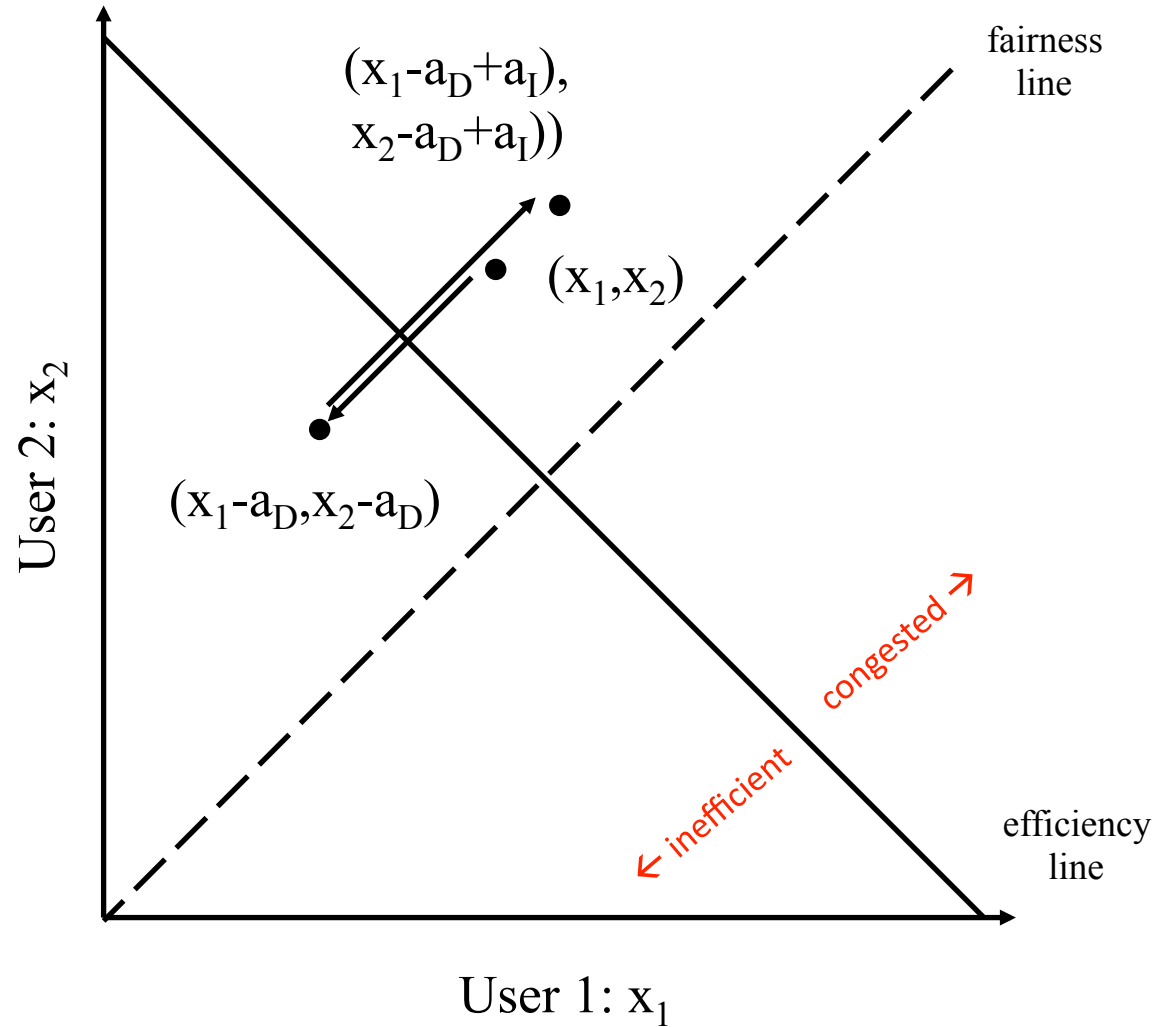

MIMD

- Increase: x^*b_I
- Decrease: x^*b_D
- **Does not converge to fairness**

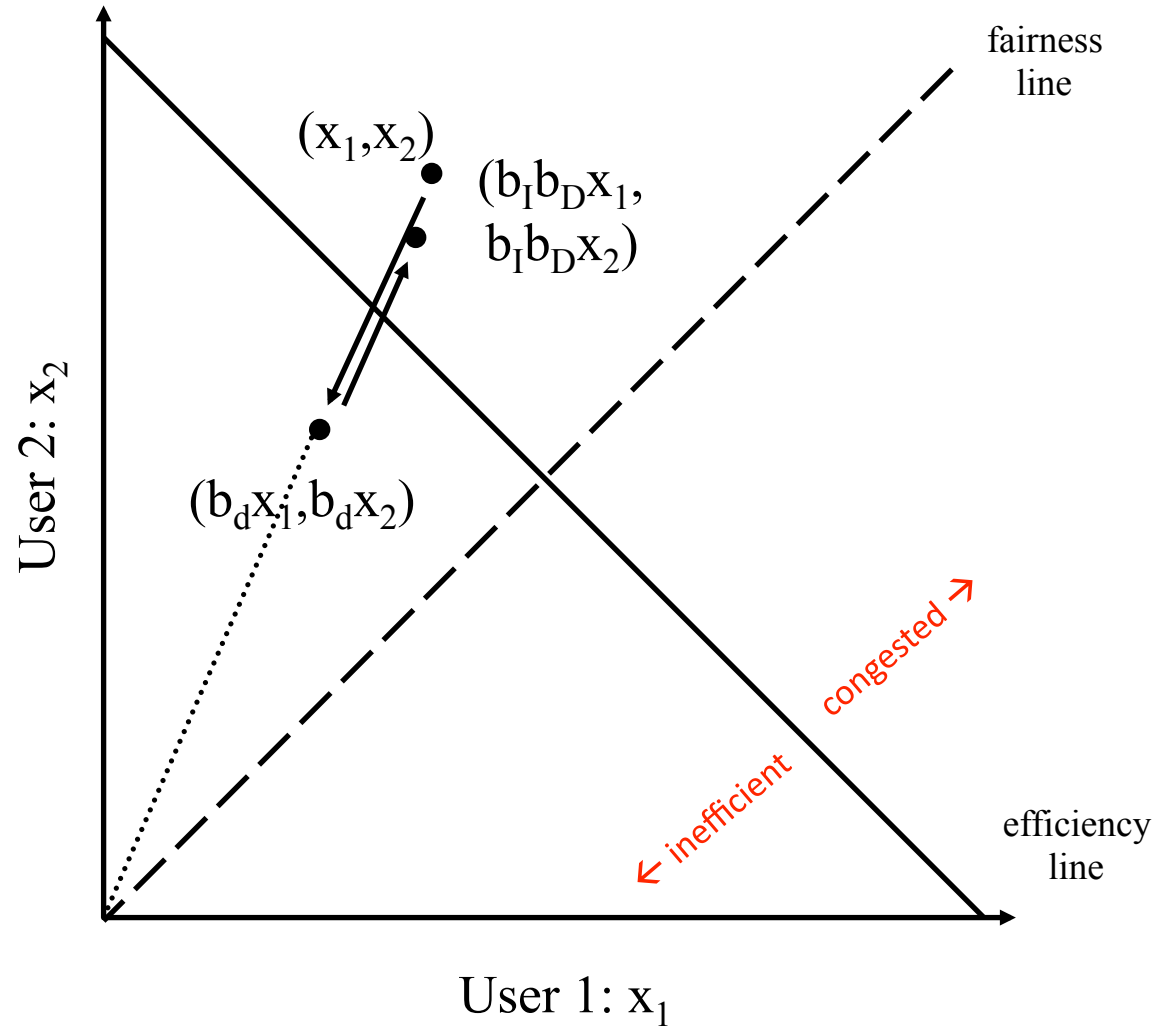

AIMD

- Increase: $x+a_I$
- Decrease: $x*b_D$
- Converges to fairness

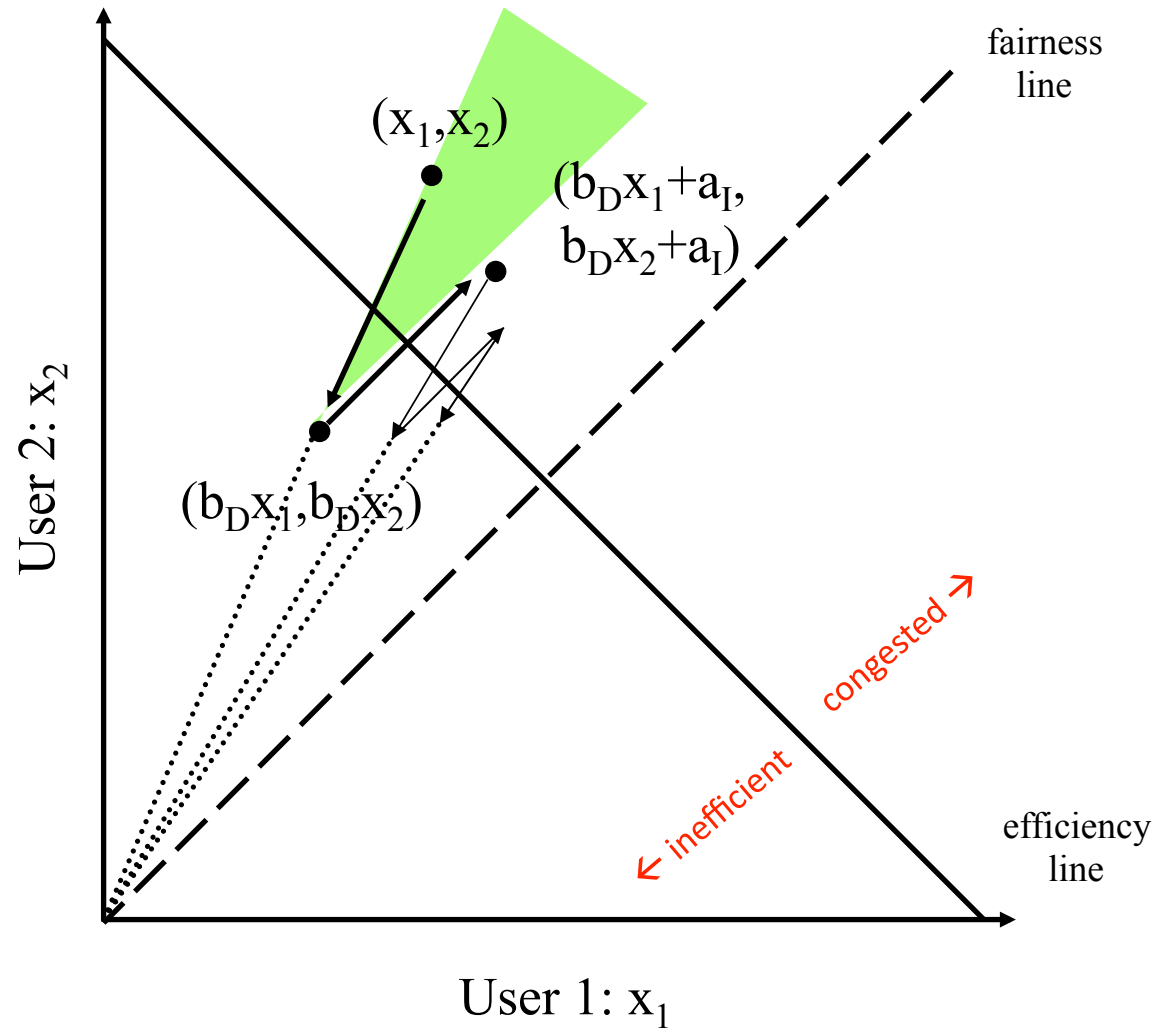

Why is AIMD fair? (a pretty animation...)

Two competing sessions:

- Additive increase gives slope of 1, as throughput increases
- multiplicative decrease decreases throughput proportionally

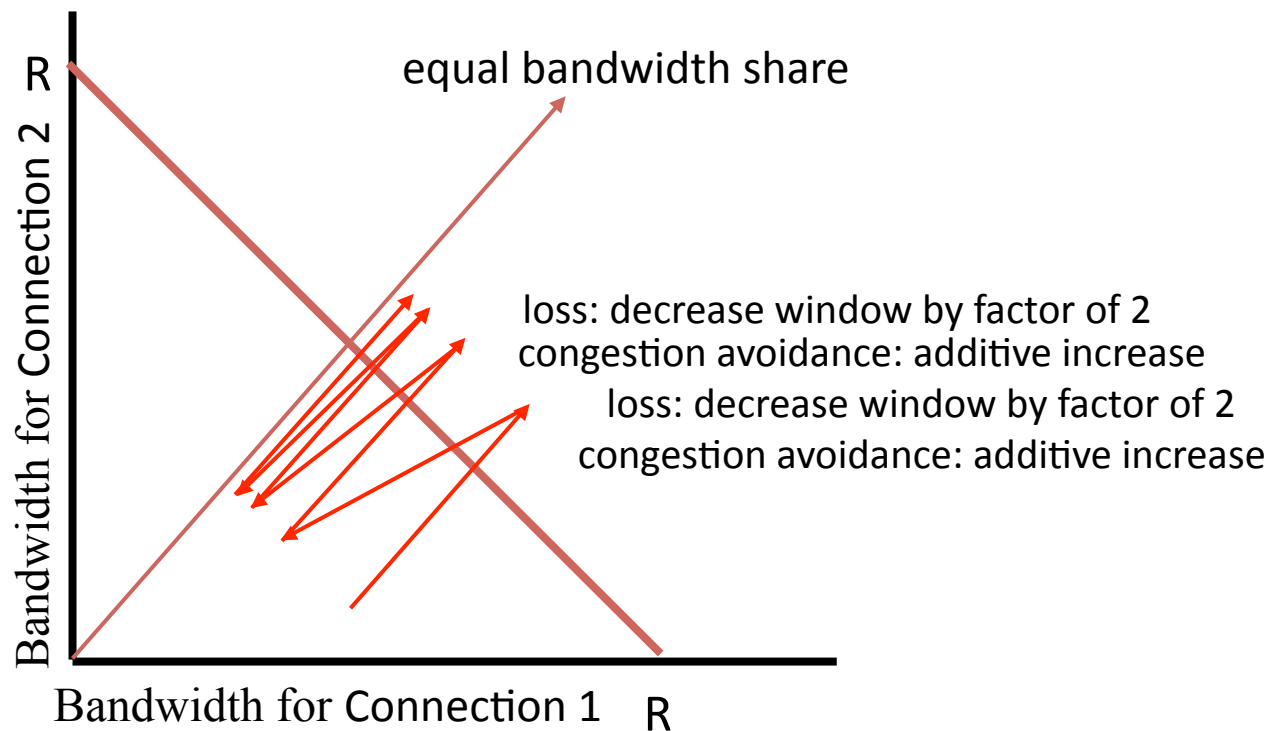

AIMD Sharing Dynamics

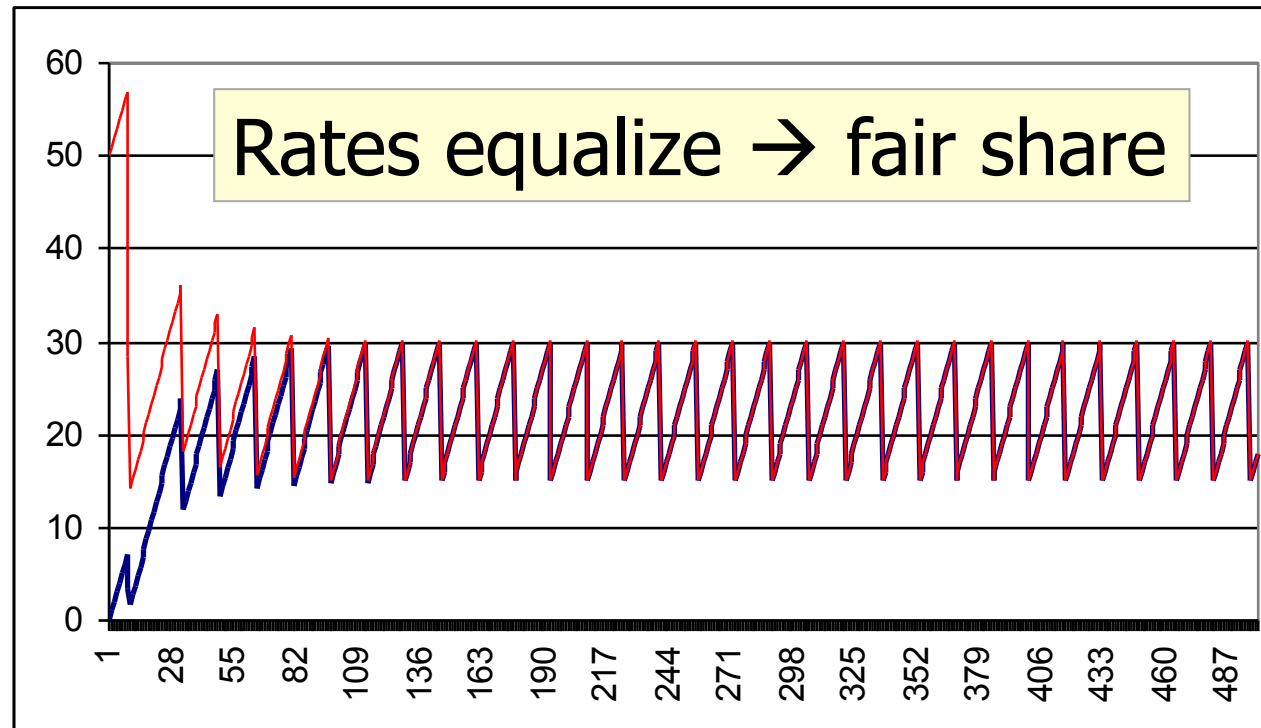
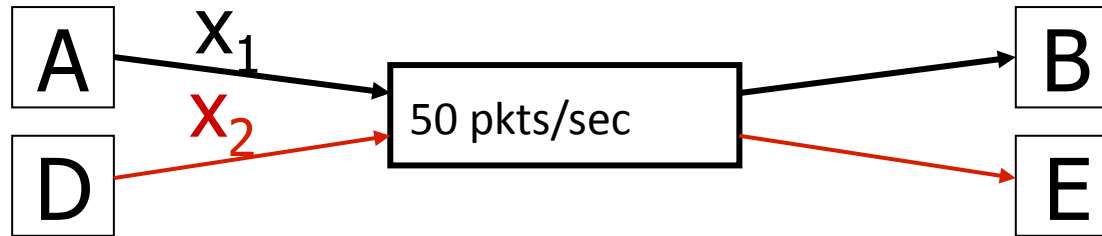

AIAD Sharing Dynamics

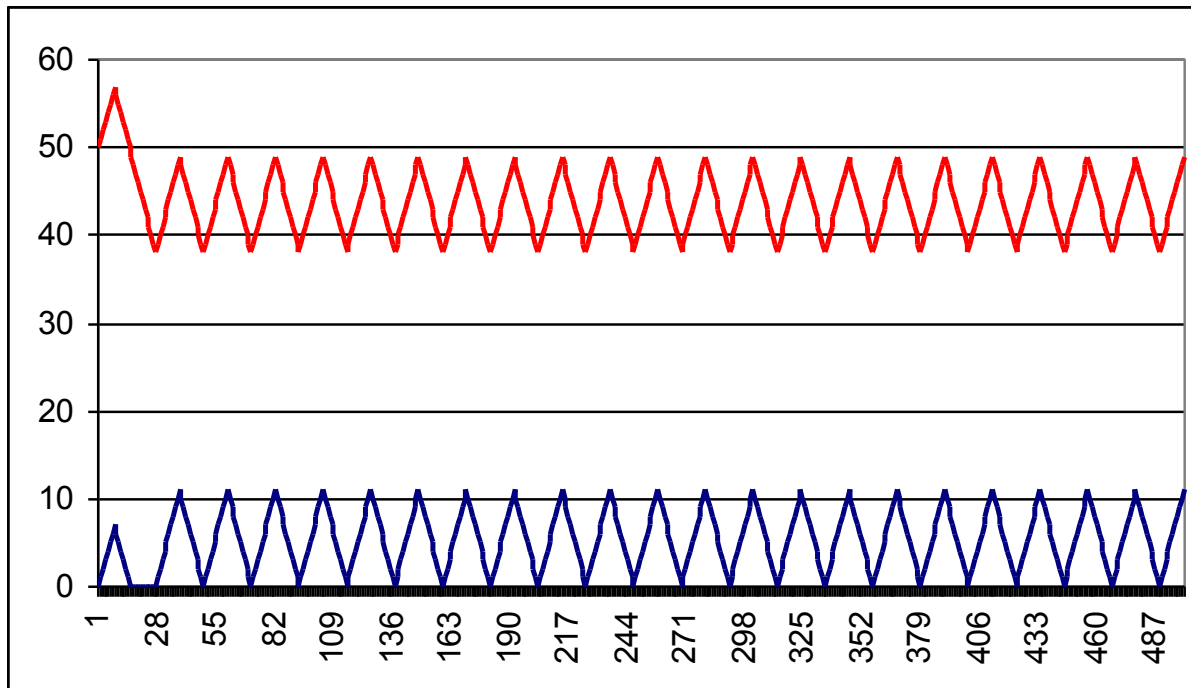
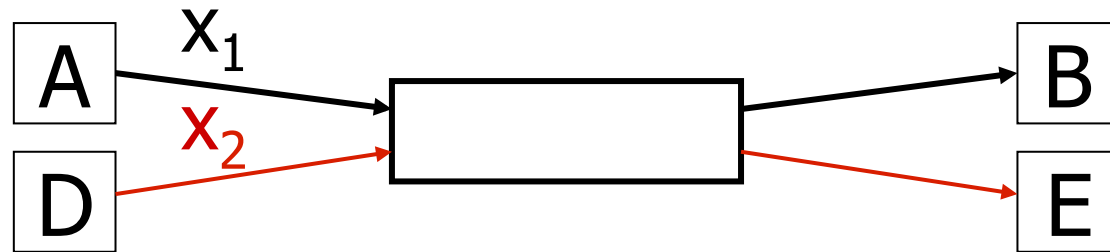

TCP Congestion Control Details

Implementation

- **State at sender**
 - **CWND** (initialized to a small constant)
 - **ssthresh** (initialized to a large constant)
 - [Also **dupACKcount** and **timer**, as before]
- **Events**
 - ACK (new data)
 - dupACK (duplicate ACK for old data)
 - Timeout

Event: ACK (new data)

- If $CWND < ssthresh$
 - $CWND += 1$

- *CWND packets per RTT*
- *Hence after one RTT with no drops:*
 $CWND = 2 \times CWND$

Event: ACK (new data)

- If $CWND < ssthresh$
 - $CWND += 1$

Slow start phase

- Else
 - $CWND = CWND + 1/CWND$

*“Congestion Avoidance” phase
(additive increase)*

- *CWND packets per RTT*
- *Hence after one RTT with no drops:*
 $CWND = CWND + 1$

Event: TimeOut

- On Timeout
 - $ssthresh \leftarrow CWND/2$
 - $CWND \leftarrow 1$

Event: dupACK

- dupACKcount ++
- If dupACKcount = 3 /* fast retransmit */
 - ssthresh = CWND/2
 - CWND = CWND/2

Example

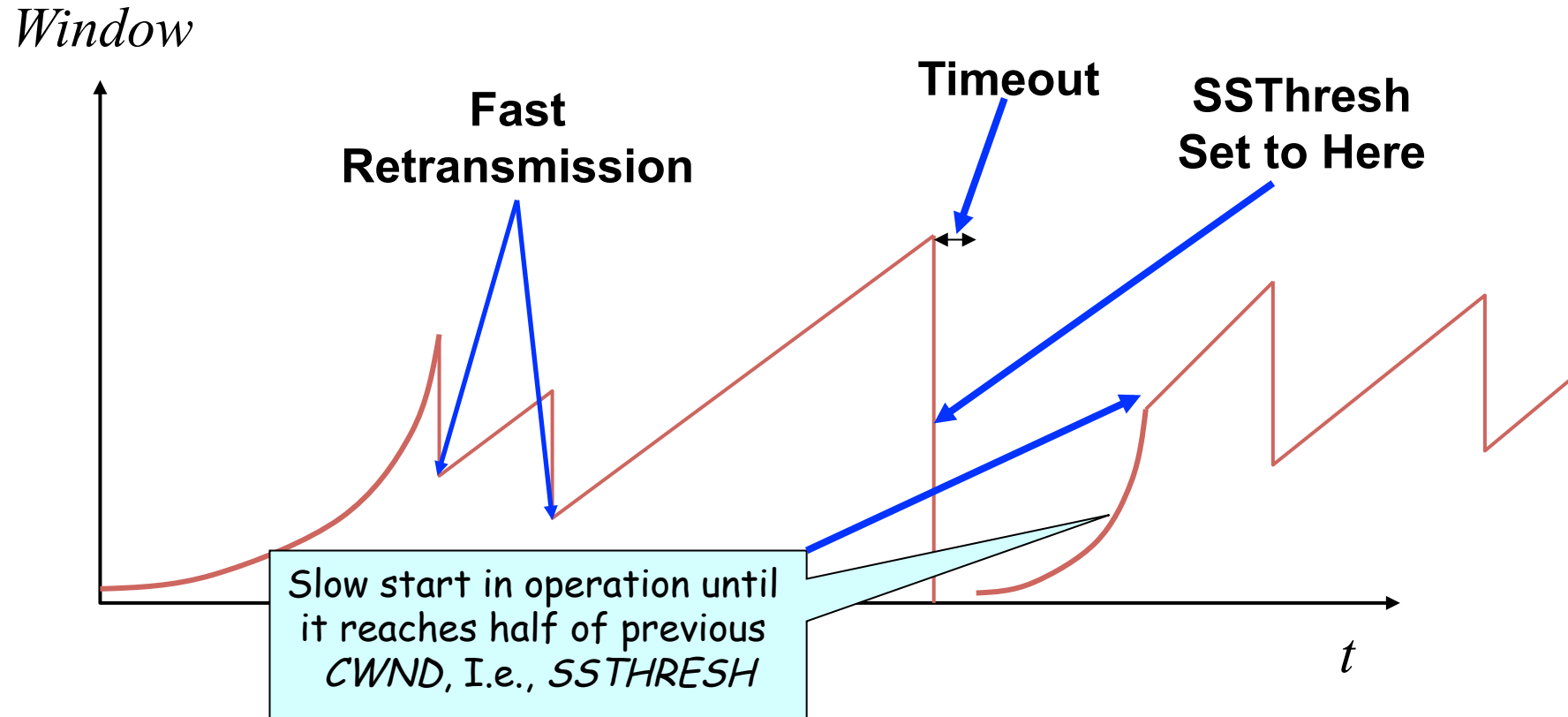

Slow-start restart: Go back to $CWND = 1$ MSS, but take advantage of knowing the previous value of $CWND$

- What does TCP do?
 - ARQ windowing, set-up, tear-down
- Flow Control in TCP
- Congestion Control in TCP
 - AIMD, Fast-Recovery

One Final Phase: Fast Recovery

- The problem: congestion avoidance too slow in recovering from an isolated loss

Example (in units of MSS, not bytes)

- Consider a TCP connection with:
 - CWND=10 packets
 - Last ACK was for packet # 101
 - i.e., receiver expecting next packet to have seq. no. 101
- 10 packets [101, 102, 103,..., 110] are in flight
 - Packet 101 is dropped
 - What ACKs do they generate?
 - And how does the sender respond?

Timeline

- ACK 101 (due to 102) cwnd=10 dupACK#1 (no xmit)
- ACK 101 (due to 103) cwnd=10 dupACK#2 (no xmit)
- ACK 101 (due to 104) cwnd=10 dupACK#3 (no xmit)
- RETRANSMIT 101 ssthresh=5 cwnd= 5
- ACK 101 (due to 105) cwnd=5 + 1/5 (no xmit)
- ACK 101 (due to 106) cwnd=5 + 2/5 (no xmit)
- ACK 101 (due to 107) cwnd=5 + 3/5 (no xmit)
- ACK 101 (due to 108) cwnd=5 + 4/5 (no xmit)
- ACK 101 (due to 109) cwnd=5 + 5/5 (no xmit)
- ACK 101 (due to 110) cwnd=6 + 1/5 (no xmit)
- ACK 111 (due to 101) ← only now can we transmit new packets
- Plus no packets in flight so ACK “clocking” (to increase CWND) stalls for another RTT

Solution: Fast Recovery

Idea: Grant the sender temporary “credit” for each dupACK so as to keep packets in flight

- If dupACKcount = 3
 - ssthresh = cwnd/2
 - cwnd = ssthresh + 3
- While in fast recovery
 - cwnd = cwnd + 1 for each additional duplicate ACK
- Exit fast recovery after receiving new ACK
 - set cwnd = ssthresh

Example

- Consider a TCP connection with:
 - CWND=10 packets
 - Last ACK was for packet # 101
 - i.e., receiver expecting next packet to have seq. no. 101
- 10 packets [101, 102, 103,..., 110] are in flight
 - Packet 101 is dropped

Timeline

- ACK 101 (due to 102) cwnd=10 dup#1
- ACK 101 (due to 103) cwnd=10 dup#2
- ACK 101 (due to 104) cwnd=10 dup#3
- REXMIT 101 ssthresh=5 cwnd= 8 (5+3)
- ACK 101 (due to 105) cwnd= 9 (no xmit)
- ACK 101 (due to 106) cwnd=10 (no xmit)
- ACK 101 (due to 107) cwnd=11 (xmit 111)
- ACK 101 (due to 108) cwnd=12 (xmit 112)
- ACK 101 (due to 109) cwnd=13 (xmit 113)
- ACK 101 (due to 110) cwnd=14 (xmit 114)
- ACK 111 (due to 101) cwnd = 5 (xmit 115) ← exiting fast recovery
- Packets 111-114 already in flight
- ACK 112 (due to 111) cwnd = $5 + 1/5$ ← back in congestion avoidance

Putting it all together: The TCP State Machine (partial)

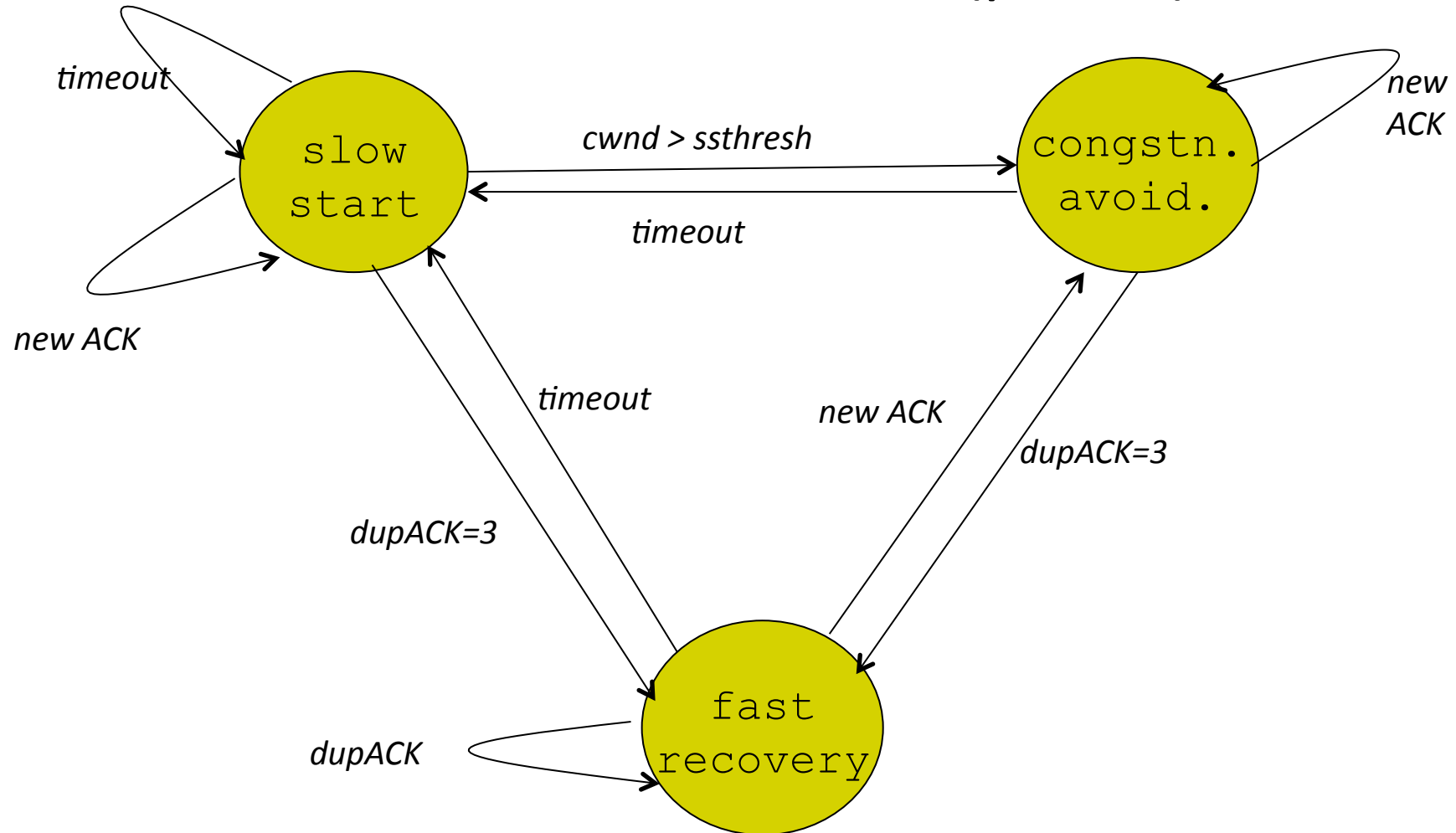

- How are *ssthresh*, *CWND* and *dupACKcount* updated for each event that causes a state transition?

TCP Flavors

- TCP-Tahoe
 - $\text{cwnd} = 1$ on triple dupACK
- TCP-Reno
 - $\text{cwnd} = 1$ on timeout
 - $\text{cwnd} = \text{cwnd}/2$ on triple dupack
- TCP-newReno
 - TCP-Reno + improved fast recovery
- TCP-SACK
 - incorporates selective acknowledgements

- What does TCP do?
 - ARQ windowing, set-up, tear-down
- Flow Control in TCP
- Congestion Control in TCP
 - AIMD, Fast-Recovery, Throughput

TCP Throughput Equation

A Simple Model for TCP Throughput

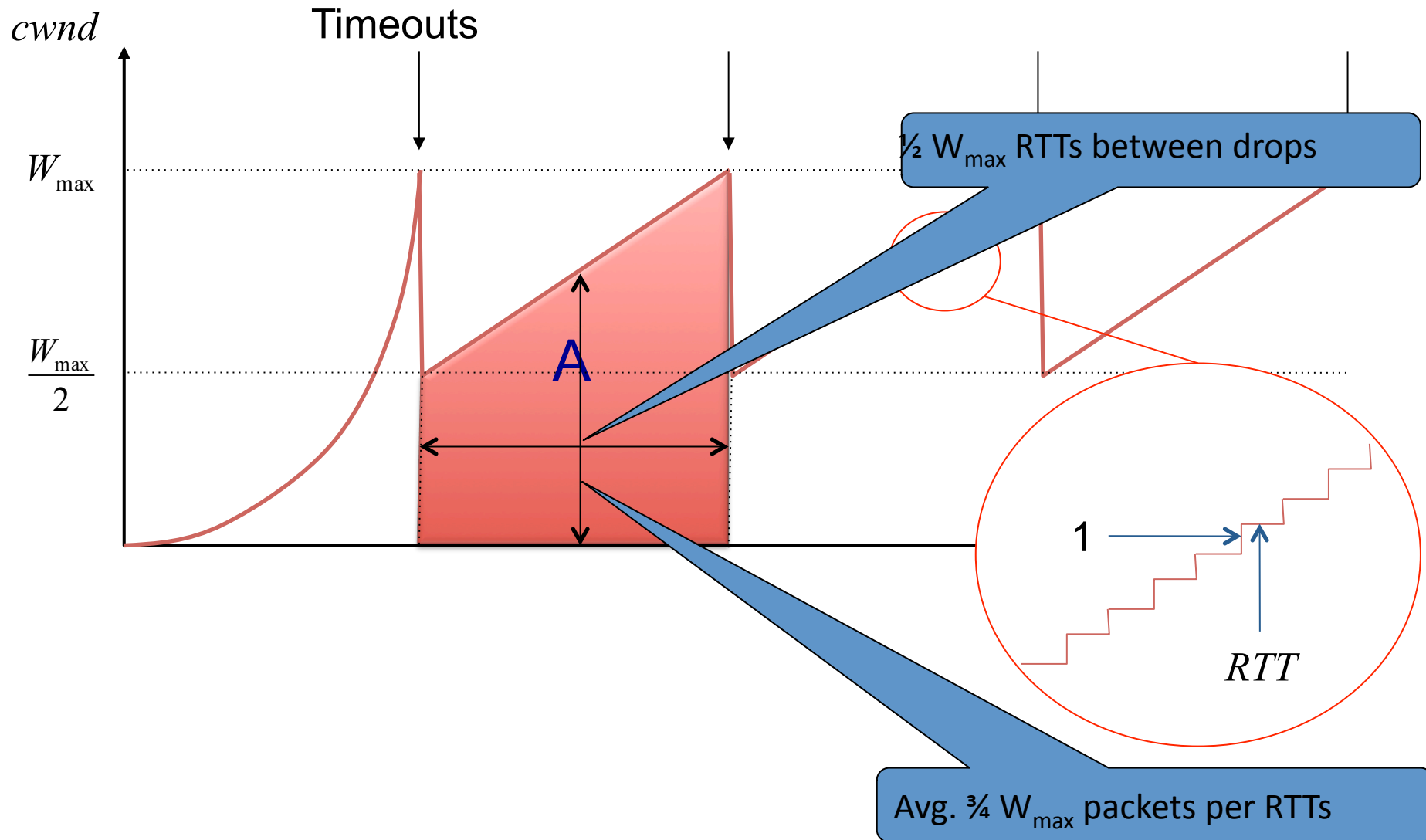

A Simple Model for TCP Throughput

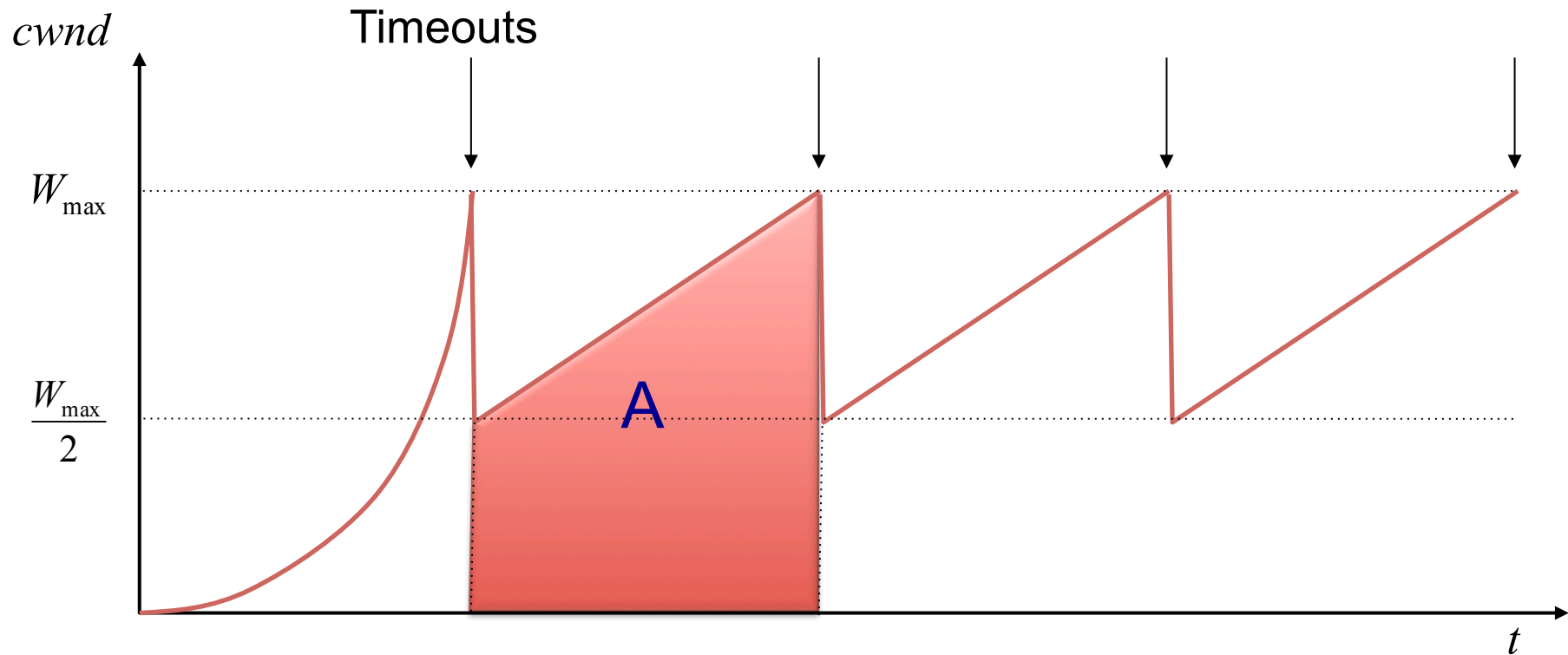

Packet drop rate, $p = 1 / A$, where $A = \frac{3}{8} W_{\max}^2$

$$\text{Throughput, } B = \frac{A}{\left(\frac{W_{\max}}{2}\right) RTT} = \sqrt{\frac{3}{2}} \frac{1}{RTT \sqrt{p}}$$

Some implications: (1) Fairness

$$\text{Throughput, } B = \sqrt{\frac{3}{2}} \frac{1}{RTT \sqrt{p}}$$

- Flows get throughput inversely proportional to RTT
 - Is this fair?

Some Implications:

(2) How does this look at high speed?

- Assume that $RTT = 100\text{ms}$, $MSS=1500\text{bytes}$
- What value of p is required to go 100Gbps ?
 - Roughly 2×10^{-12}
- How long between drops?
 - Roughly 16.6 hours
- How much data has been sent in this time?
 - Roughly 6 petabits
- These are not practical numbers!

Some implications:
(3) Rate-based Congestion Control

$$\text{Throughput, } B = \sqrt{\frac{3}{2}} \frac{1}{RTT \sqrt{p}}$$

- One can dispense with TCP and just match eqtn:
 - Equation-based congestion control
 - Measure drop percentage p , and set rate accordingly
 - Useful for streaming applications

Some Implications: (4) Lossy Links

- TCP assumes all losses are due to congestion
- What happens when the link is lossy?
- Throughput $\sim 1/\sqrt{p}$ where p is loss prob.
- This applies even for non-congestion losses!

Other Issues: Cheating

- Cheating pays off
- Some favorite approaches to cheating:
 - Increasing CWND faster than 1 per RTT
 - Using large initial CWND
 - Opening many connections

Increasing CWND Faster

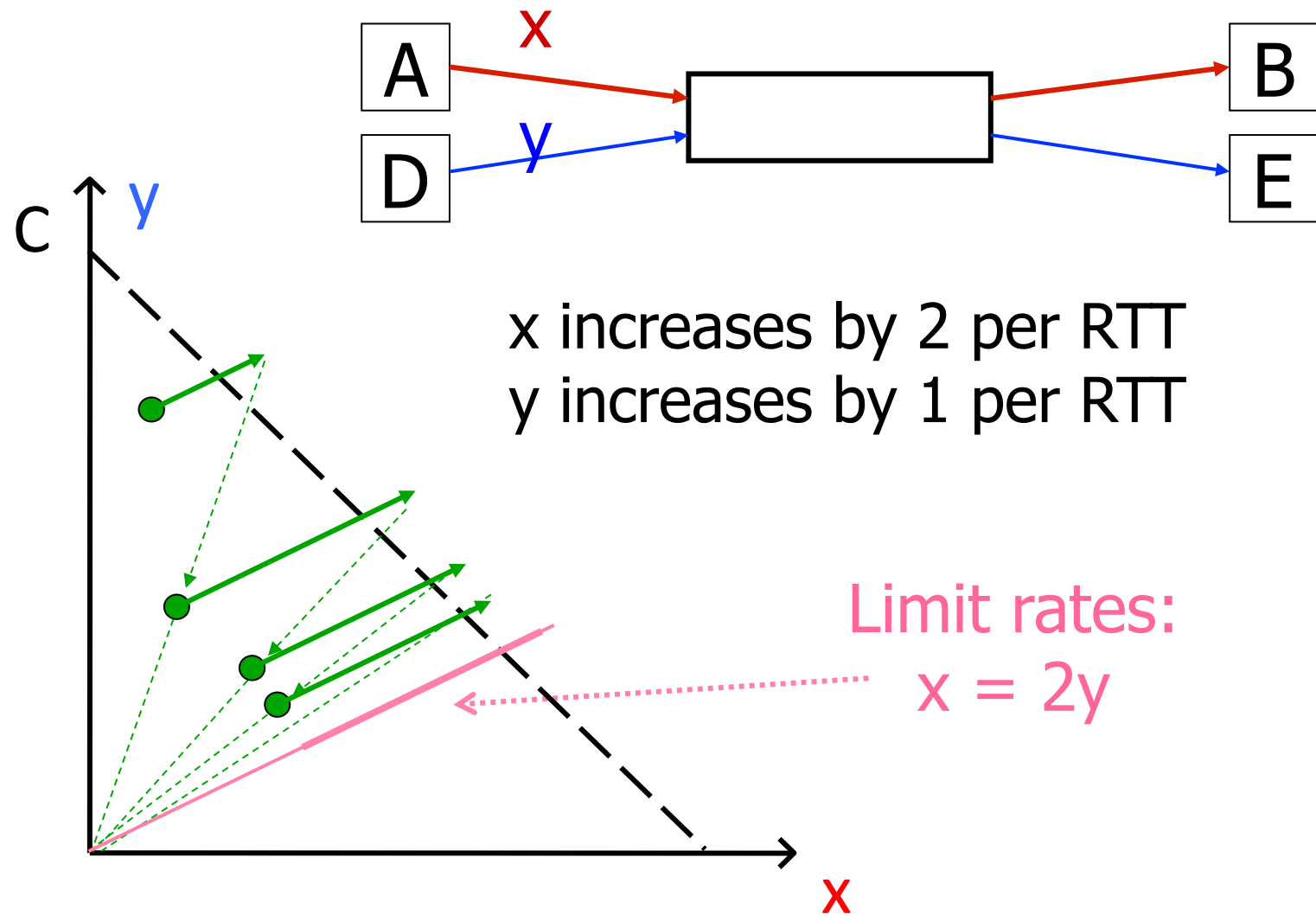

A Closer look at problems with TCP Congestion Control

TCP State Machine

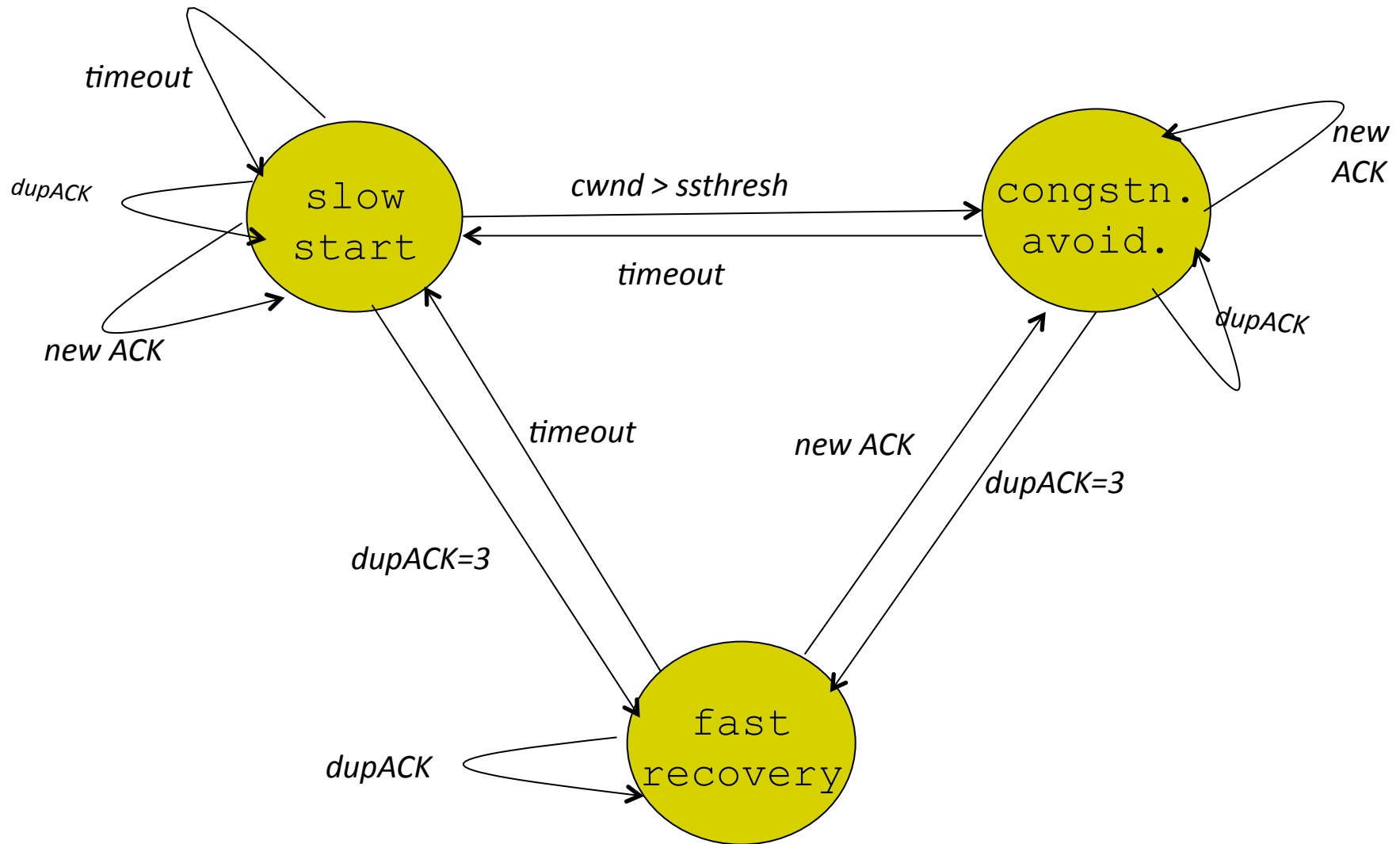

TCP State Machine

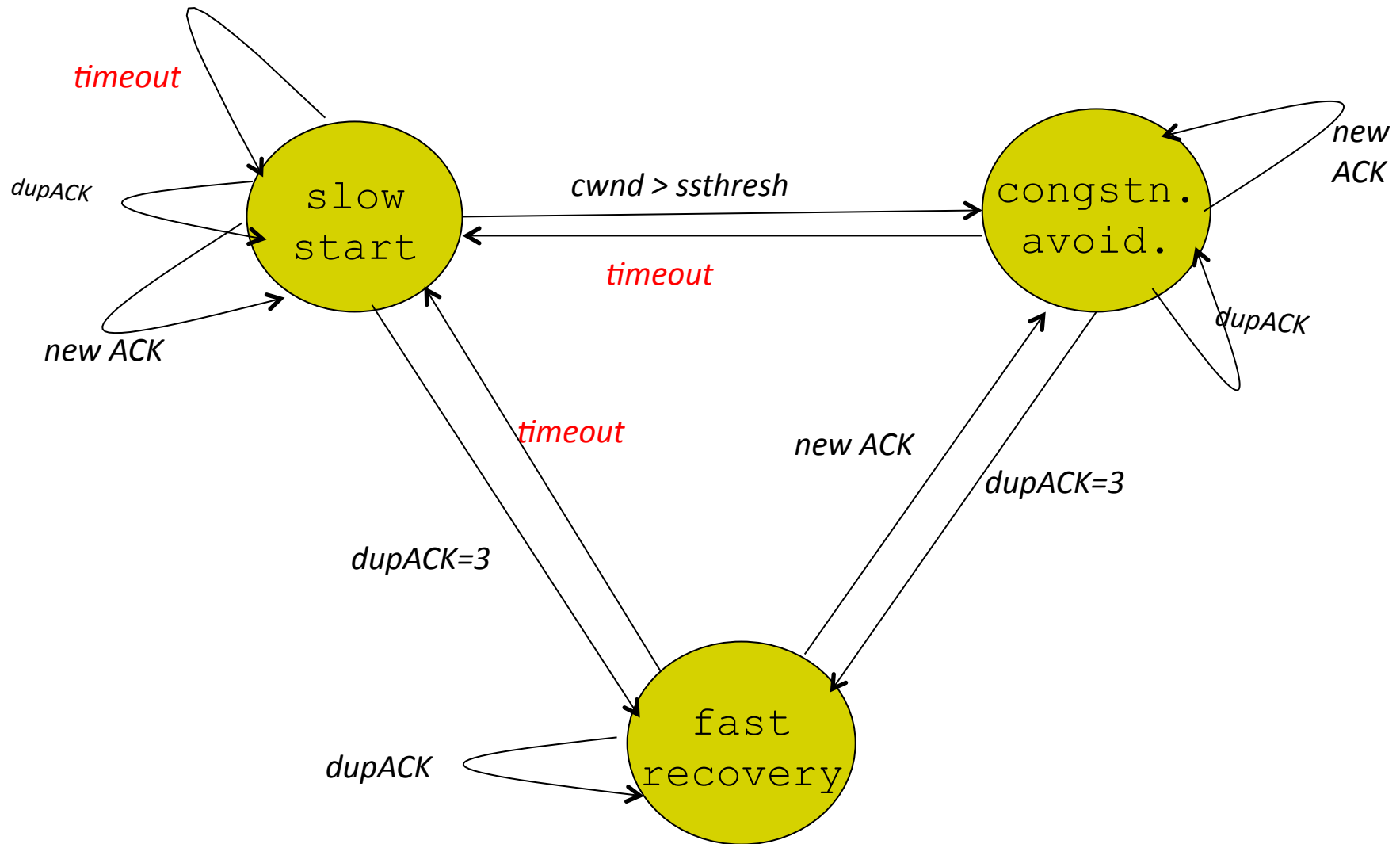

TCP State Machine

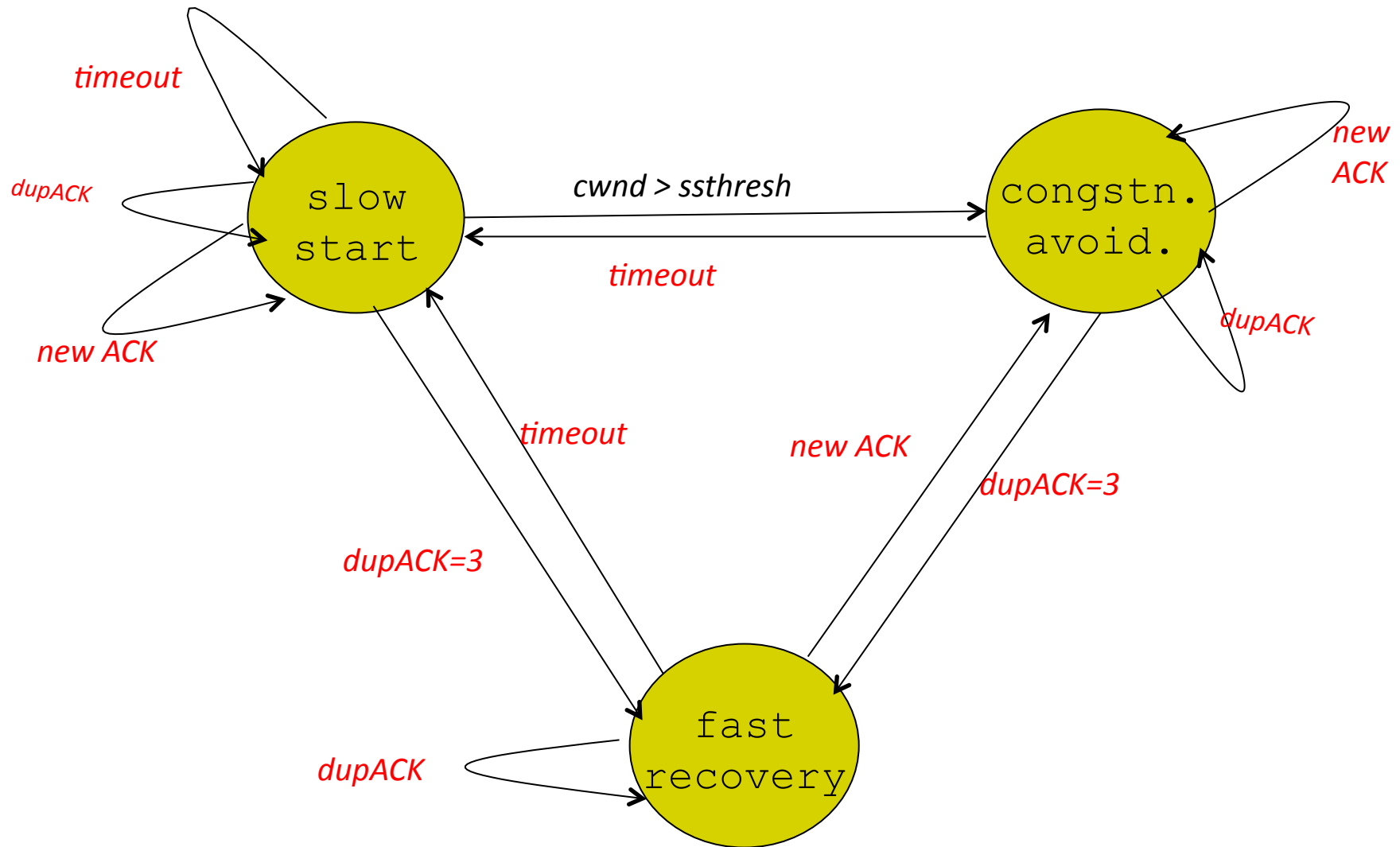

TCP State Machine

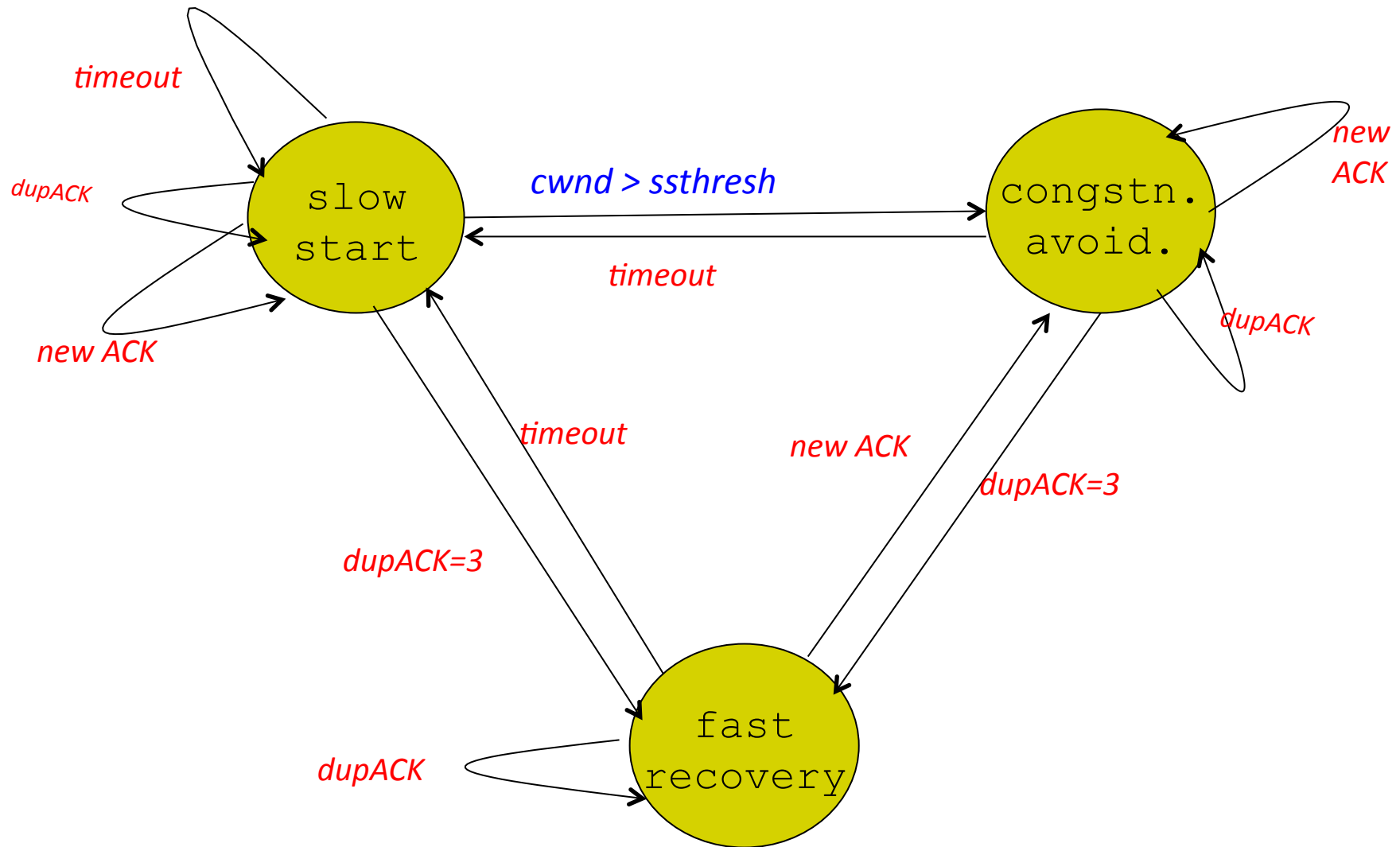

TCP Flavors

- TCP-Tahoe
 - $CWND = 1$ on triple dupACK
- TCP-Reno
 - $CWND = 1$ on timeout
 - $CWND = CWND/2$ on triple dupack
- TCP-newReno
 - TCP-Reno + improved fast recovery
- TCP-SACK
 - incorporates selective acknowledgements



Our default assumption

Interoperability

- How can all these algorithms coexist? Don't we need a single, uniform standard?
- What happens if I'm using Reno and you are using Tahoe, and we try to communicate?

TCP Throughput Equation

A Simple Model for TCP Throughput

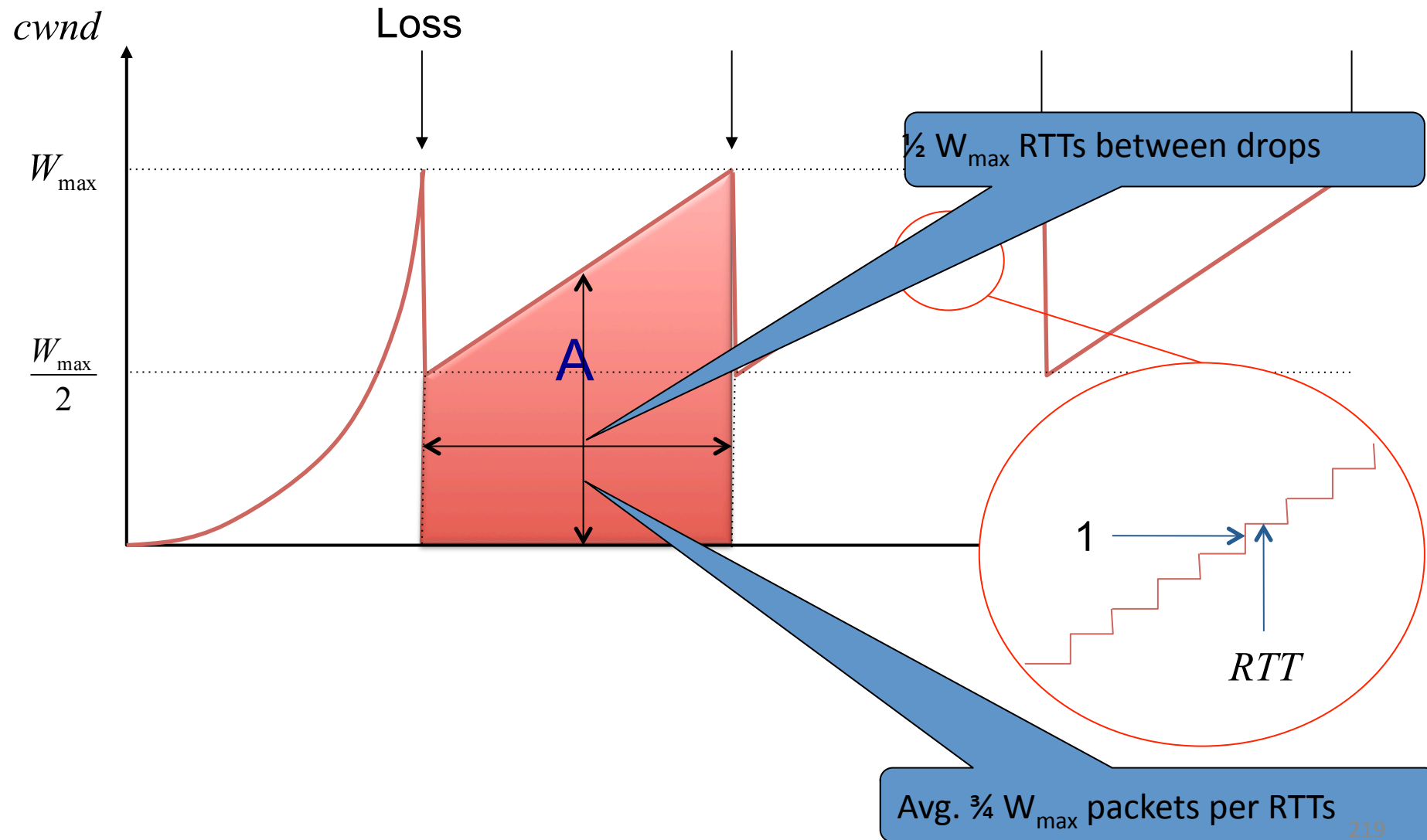

A Simple Model for TCP Throughput

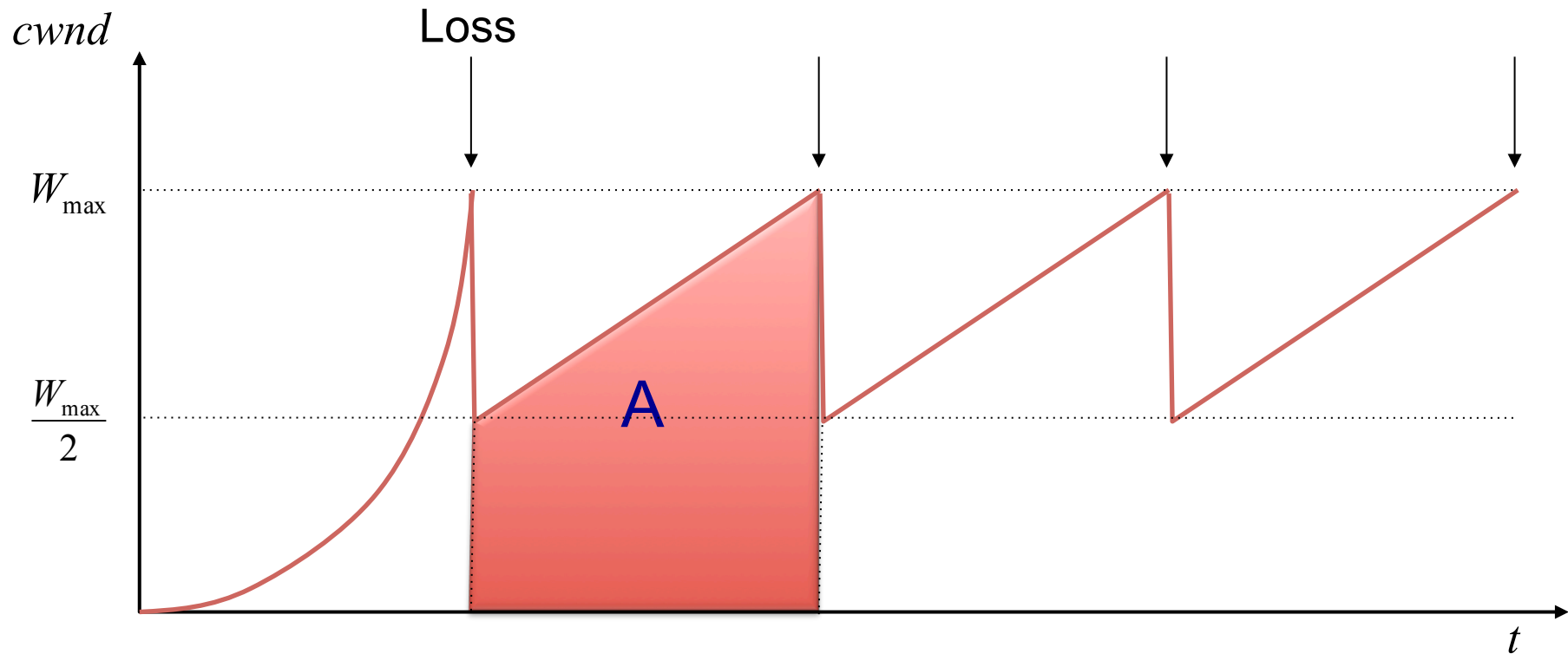

Packet drop rate, $p = 1 / A$, where $A = \frac{3}{8} W_{\max}^2$

$$\text{Throughput, } B = \frac{A}{\left(\frac{W_{\max}}{2}\right) RTT} = \sqrt{\frac{3}{2}} \frac{1}{RTT \sqrt{p}}$$

Implications (1): Different RTTs

$$\text{Throughput} = \sqrt{\frac{3}{2}} \frac{1}{RTT \sqrt{p}}$$

- Flows get throughput inversely proportional to RTT
- TCP unfair in the face of heterogeneous RTTs!

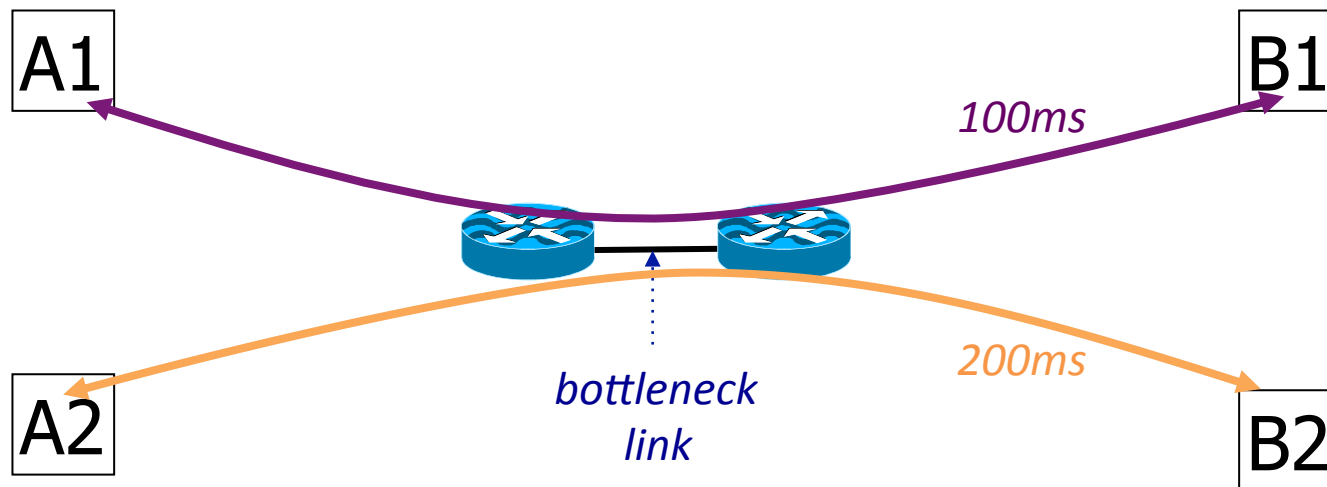

Implications (2): High Speed TCP

$$\text{Throughput} = \sqrt{\frac{3}{2}} \frac{1}{RTT \sqrt{p}}$$

- Assume $RTT = 100\text{ms}$, $MSS=1500\text{bytes}$
- What value of p is required to reach 100Gbps throughput
 - $\sim 2 \times 10^{-12}$
- How long between drops?
 - ~ 16.6 hours
- How much data has been sent in this time?
 - ~ 6 petabits
- These are not practical numbers!

Adapting TCP to High Speed

- Once past a threshold speed, increase CWND faster
 - A proposed standard [Floyd'03]: once speed is past some threshold, change equation to p^{-8} rather than p^{-5}
 - Let the additive constant in AIMD depend on CWND
- Other approaches?
 - Multiple simultaneous connections (hack but works today)
 - Router-assisted approaches (will see shortly)

Implications (3): *Rate*-based CC

$$\text{Throughput} = \sqrt{\frac{3}{2}} \frac{1}{RTT \sqrt{p}}$$

- TCP throughput is “choppy”
 - repeated swings between $W/2$ to W
- Some apps would prefer sending at a steady rate
 - e.g., streaming apps
- **A solution: “Equation-Based Congestion Control”**
 - ditch TCP’s increase/decrease rules and just follow the equation
 - measure drop percentage p , and set rate accordingly
- Following the TCP equation ensures we’re “TCP friendly”
 - i.e., use no more than TCP does in similar setting

- What does TCP do?
 - ARQ windowing, set-up, tear-down
- Flow Control in TCP
- Congestion Control in TCP
 - AIMD, Fast-Recovery, Throughput
- Limitations of TCP Congestion Control

Other Limitations of TCP Congestion Control

(4) Loss not due to congestion?

- TCP will confuse **any loss event** with congestion
- Flow will cut its rate
 - Throughput $\sim 1/\sqrt{p}$ where p is loss prob.
 - Applies even for non-congestion losses!
- We'll look at proposed solutions shortly...

(5) How do short flows fare?

- 50% of flows have < 1500B to send; 80% < 100KB
- Implication (1): short flows never leave slow start!
 - short flows never attain their fair share
- Implication (2): too few packets to trigger dupACKs
 - Isolated loss may lead to timeouts
 - At typical timeout values of ~500ms, might severely impact flow completion time

(6) TCP fills up queues → long delays

- A flow deliberately overshoots capacity, until it experiences a drop
- Means that delays are large for *everyone*
 - Consider a flow transferring a 10GB file sharing a bottleneck link with 10 flows transferring 100B

(7) Cheating

- Three easy ways to cheat
 - Increasing CWND faster than +1 MSS per RTT

Increasing CWND Faster

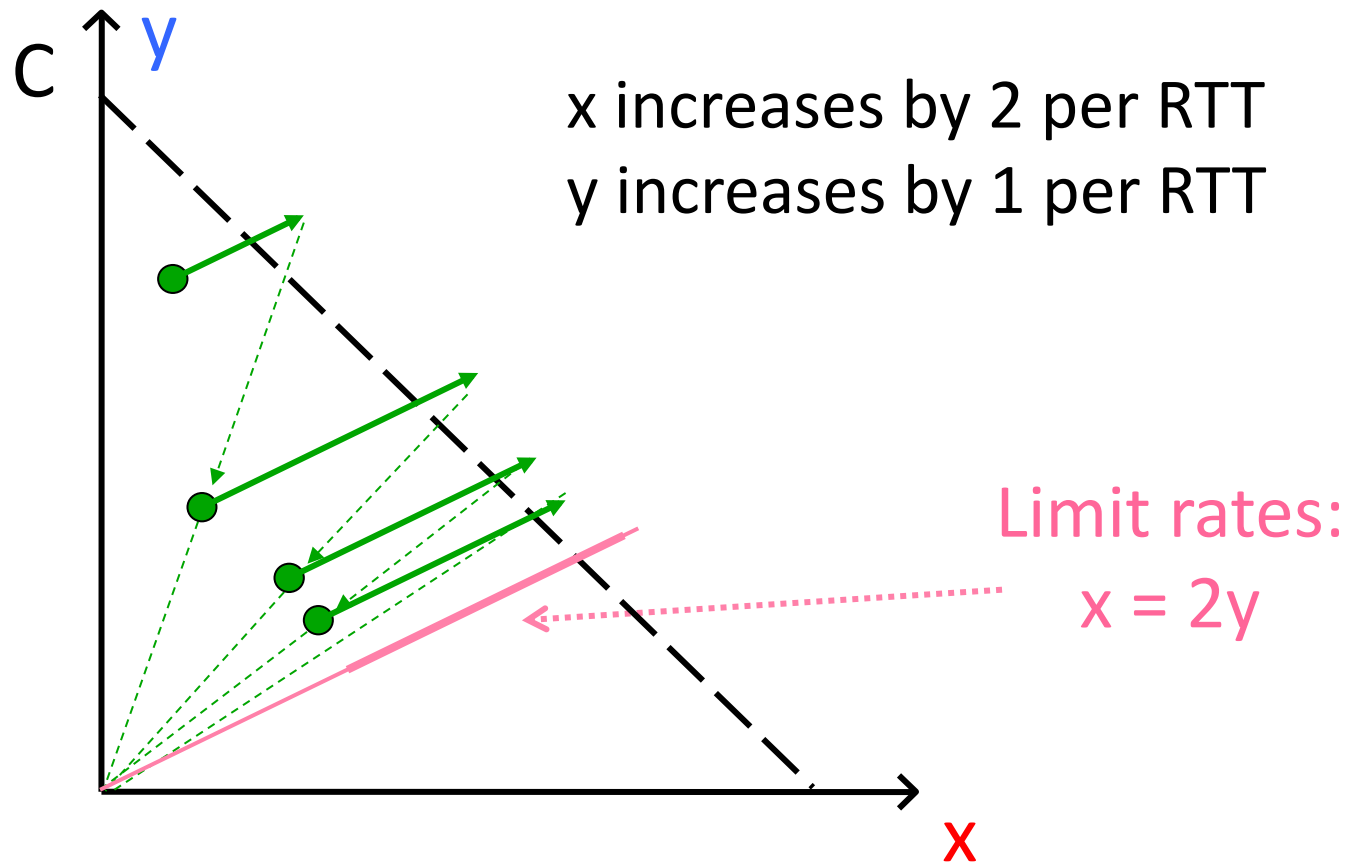

(7) Cheating

- Three easy ways to cheat
 - Increasing CWND faster than +1 MSS per RTT
 - Opening many connections

Open Many Connections

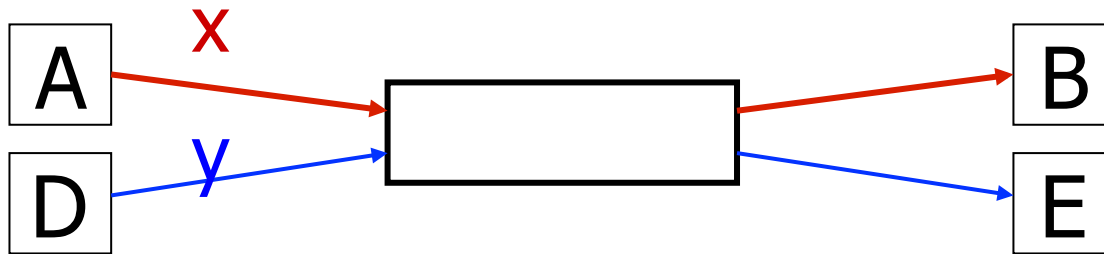

Assume

- A starts 10 connections to B
- D starts 1 connection to E
- Each connection gets about the same throughput

Then A gets 10 times more throughput than D

(7) Cheating

- Three easy ways to cheat
 - Increasing CWND faster than +1 MSS per RTT
 - Opening many connections
 - Using large initial CWND
- Why hasn't the Internet suffered a congestion collapse yet?

(8) CC intertwined with reliability

- Mechanisms for CC and reliability are tightly coupled
 - CWND adjusted based on ACKs and timeouts
 - Cumulative ACKs and fast retransmit/recovery rules
- Complicates evolution
 - Consider changing from cumulative to selective ACKs
 - A failure of modularity, not layering
- Sometimes we want CC but not reliability
 - e.g., real-time applications
- Sometimes we want reliability but not CC (?)

Recap: TCP problems

- Misled by non-congestion losses
- Fills up queues leading to high delays
- Short flows complete before discovering available capacity
- AIMD impractical for high speed links
- Sawtooth discovery too choppy for some apps
- Unfair under heterogeneous RTTs
- Tight coupling with reliability mechanisms
- Endhosts can cheat

Routers tell endpoints if they're congested

Routers tell endpoints what rate to send at

Routers enforce fair sharing

Could fix many of these with some help from routers!

- What does TCP do?
 - ARQ windowing, set-up, tear-down
- Flow Control in TCP
- Congestion Control in TCP
 - AIMD, Fast-Recovery, Throughput
- Limitations of TCP Congestion Control
- Router-assisted Congestion Control

Router-Assisted Congestion Control

- Three tasks for CC:
 - Isolation/fairness
 - Adjustment
 - Detecting congestion

How can routers ensure each flow gets its “fair share”?

Fairness: General Approach

- Routers classify packets into “flows”
 - (For now) flows are packets between same source/destination
- Each flow has its own FIFO queue in router
- Router services flows in a fair fashion
 - When line becomes free, take packet from next flow in a fair order
- What does “fair” mean exactly?

Max-Min Fairness

- Given set of bandwidth demands r_i and total bandwidth C , max-min bandwidth allocations are:

$$a_i = \min(f, r_i)$$

where f is the unique value such that $\text{Sum}(a_i) = C$

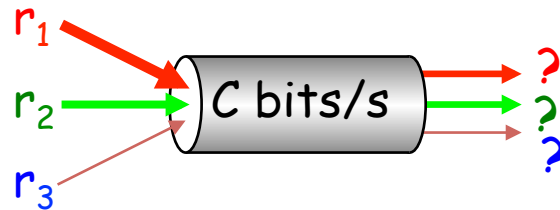

Example

- $C = 10$; $r_1 = 8$, $r_2 = 6$, $r_3 = 2$; $N = 3$
- $C/3 = 3.33 \rightarrow$
 - Can service all of r_3
 - Remove r_3 from the accounting: $C = C - r_3 = 8$; $N = 2$
- $C/2 = 4 \rightarrow$
 - Can't service all of r_1 or r_2
 - So hold them to the remaining fair share: $f = 4$

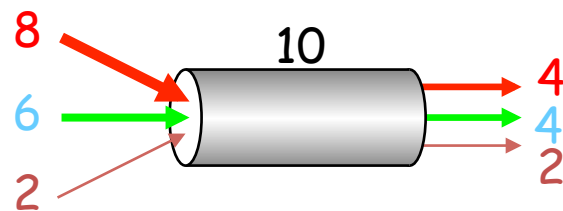

$$\begin{aligned} f &= 4: \\ \min(8, 4) &= 4 \\ \min(6, 4) &= 4 \\ \min(2, 4) &= 2 \end{aligned}$$

Max-Min Fairness

- Given set of bandwidth demands r_i and total bandwidth C , max-min bandwidth allocations are:

$$a_i = \min(f, r_i)$$

- where f is the unique value such that $\text{Sum}(a_i) = C$
- **Property:**
 - If you don't get full demand, no one gets more than you
- This is what round-robin service gives if all packets are the same size

How do we deal with packets of different sizes?

- Mental model: Bit-by-bit round robin (“fluid flow”)
- Can you do this in practice?
- No, packets cannot be preempted
- But we can approximate it
 - This is what “fair queuing” routers do

Fair Queuing (FQ)

- For each packet, compute the time at which the last bit of a packet would have left the router *if* flows are served bit-by-bit
- Then serve packets in the increasing order of their deadlines

Example

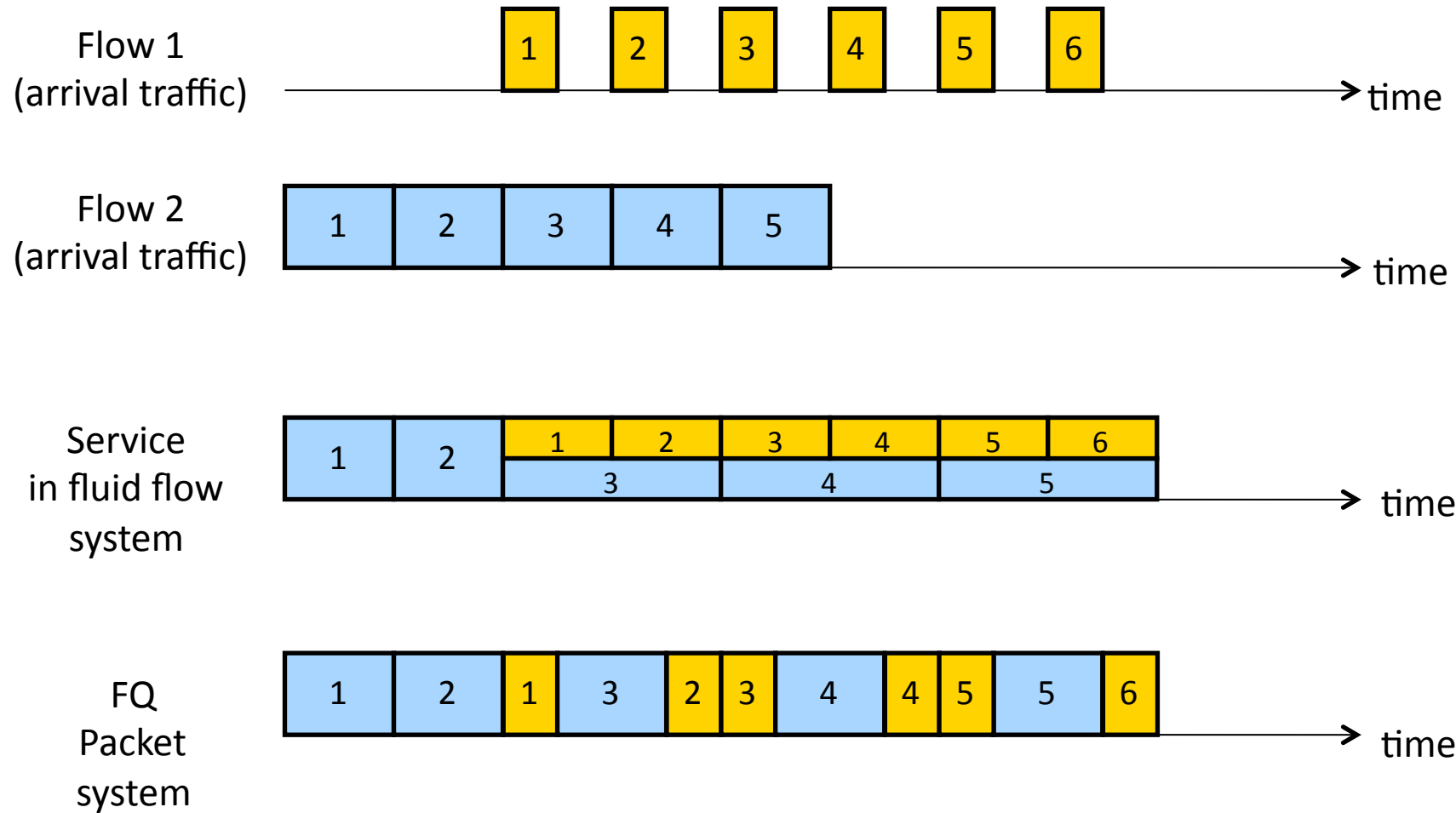

Fair Queuing (FQ)

- Think of it as an implementation of round-robin generalized to the case where not all packets are equal sized
- **Weighted** fair queuing (WFQ): assign different flows different shares
- Today, some form of WFQ implemented in almost all routers
 - Not the case in the 1980-90s, when CC was being developed
 - Mostly used to isolate traffic at larger granularities (e.g., per-prefix)

FQ vs. FIFO

- FQ advantages:
 - Isolation: cheating flows don't benefit
 - Bandwidth share does not depend on RTT
 - Flows can pick any rate adjustment scheme they want
- Disadvantages:
 - More complex than FIFO: per flow queue/state, additional per-packet book-keeping

FQ in the big picture

- FQ does not eliminate congestion → it just manages the congestion

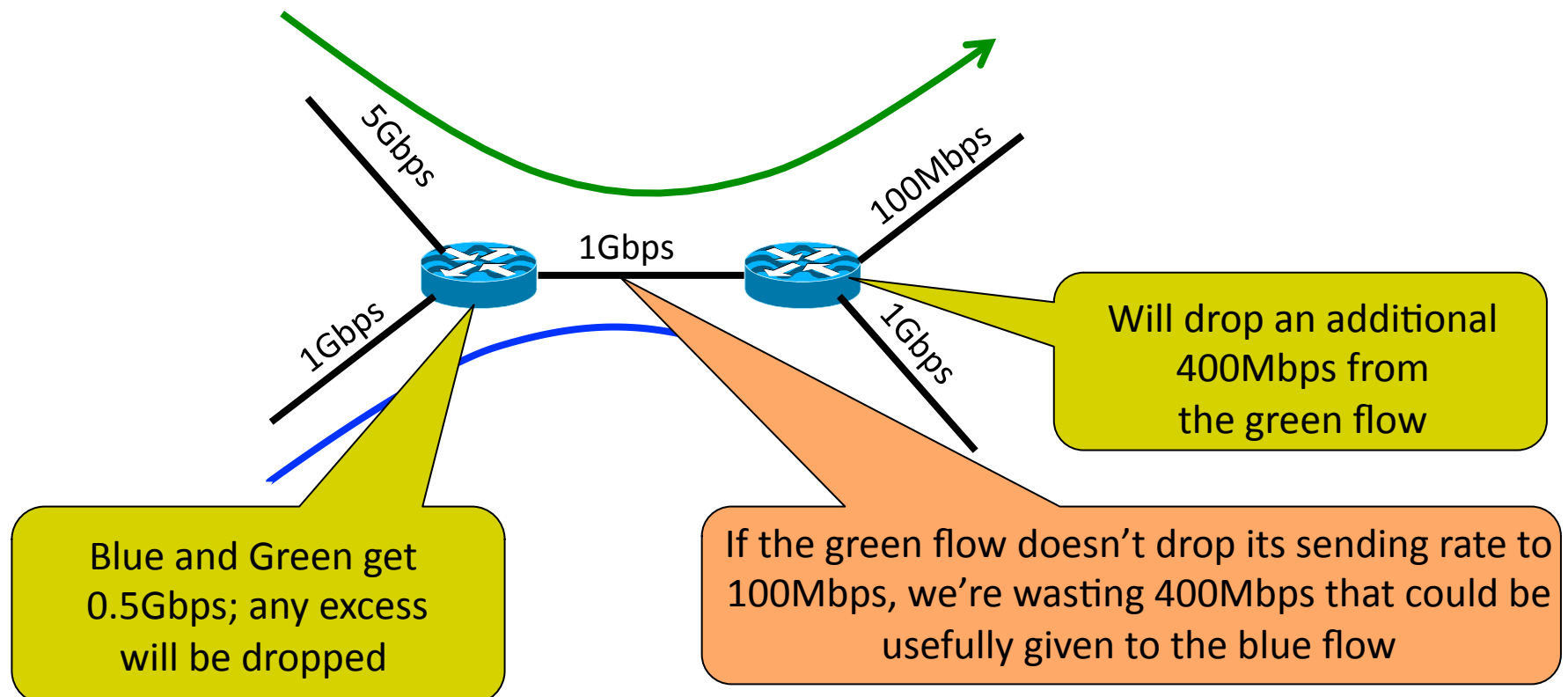

FQ in the big picture

- FQ does not eliminate congestion → it just manages the congestion
 - robust to cheating, variations in RTT, details of delay, reordering, retransmission, *etc.*
- But congestion (and packet drops) still occurs
- And we still want end-hosts to discover/adapt to their fair share!
- What would the end-to-end argument say w.r.t. congestion control?

Fairness is a controversial goal

- What if you have 8 flows, and I have 4?
 - Why should you get twice the bandwidth
- What if your flow goes over 4 congested hops, and mine only goes over 1?
 - Why shouldn't you be penalized for using more scarce bandwidth?
- And what is a flow anyway?
 - TCP connection
 - Source-Destination pair?
 - Source?

Router-Assisted Congestion Control

- CC has three different tasks:
 - Isolation/fairness
 - Rate adjustment
 - Detecting congestion

Why not just let routers tell endhosts what rate they should use?

- Packets carry “rate field”
- Routers insert “fair share” f in packet header
 - Calculated as with FQ
- End-hosts set sending rate (or window size) to f
 - hopefully (still need some policing of endhosts!)
- This is the basic idea behind the “Rate Control Protocol” (RCP) from Dukkupati *et al.* '07

Flow Completion Time: TCP vs. RCP (Ignore XCP)

Flow Duration (secs) vs. Flow Size

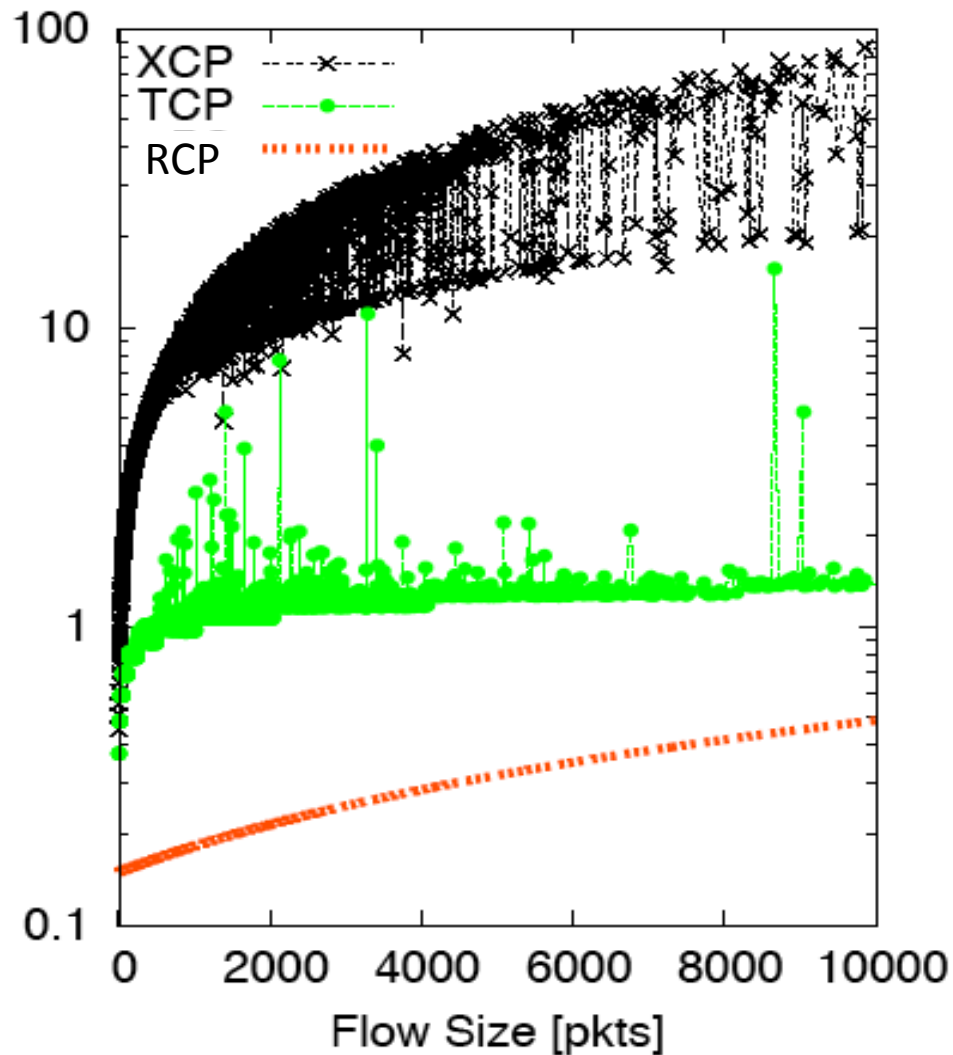

Active Flows vs. time

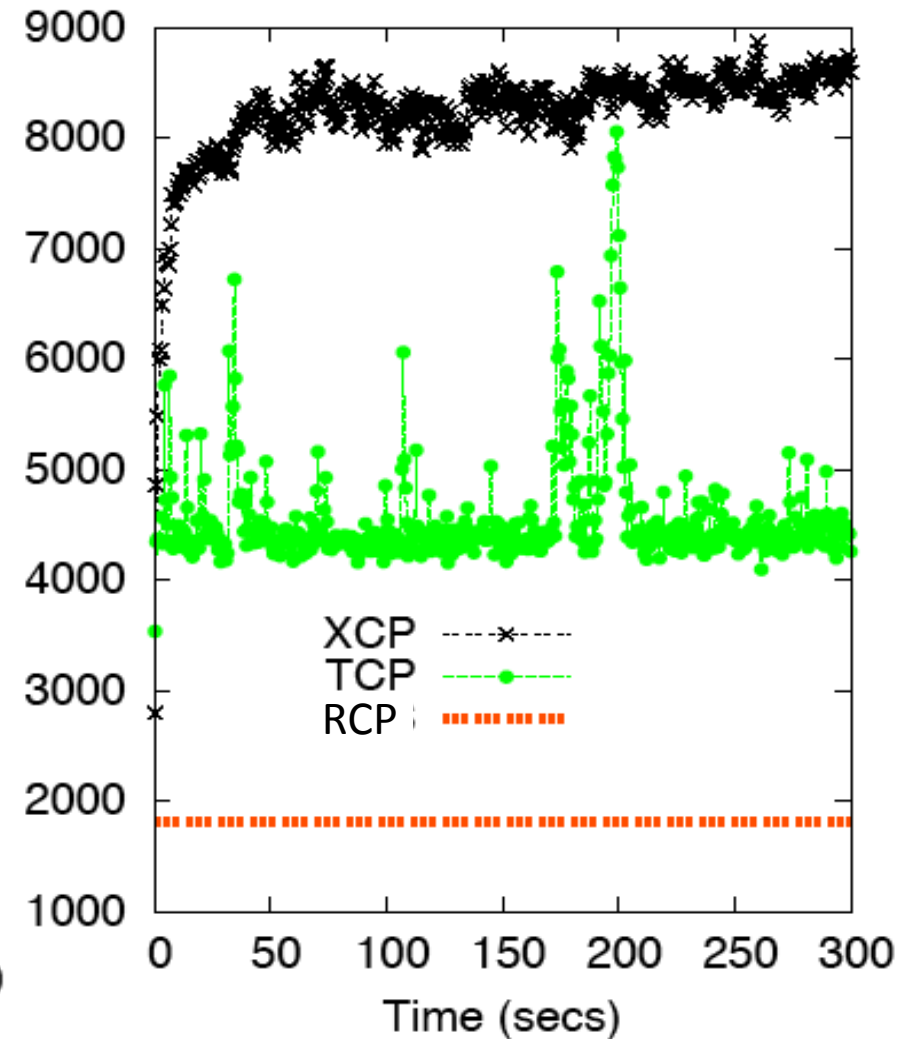

Why the improvement?

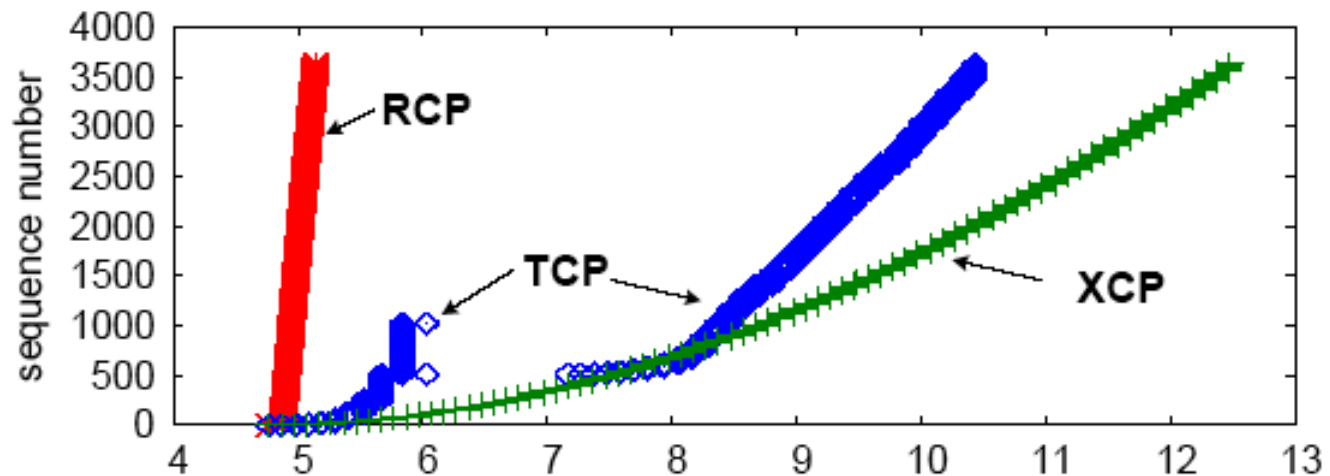
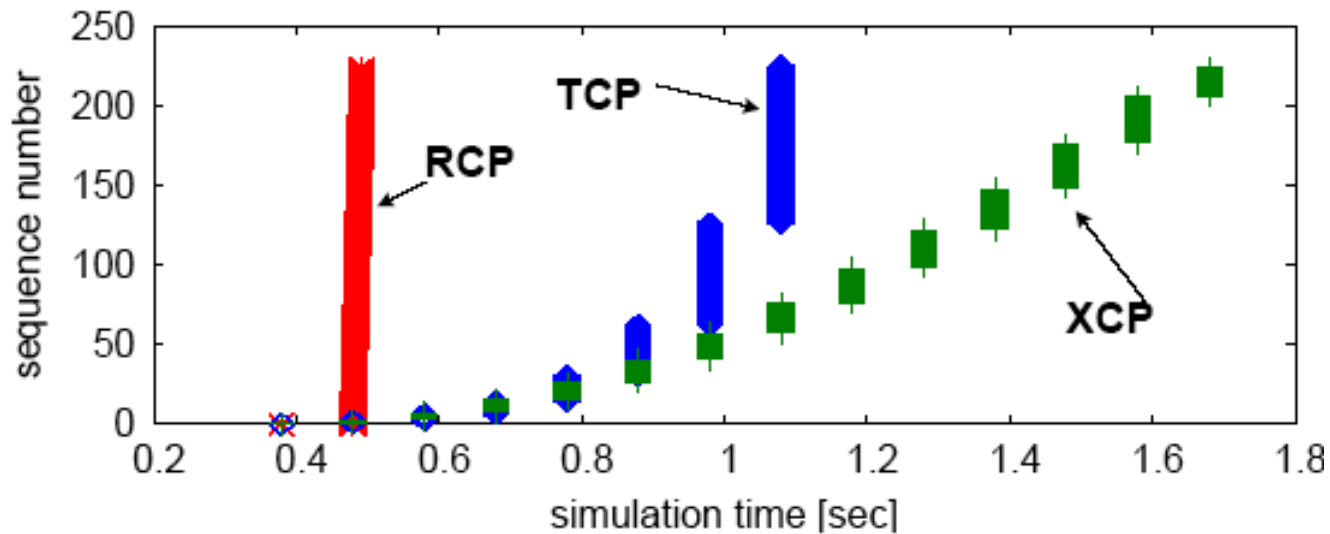

Router-Assisted Congestion Control

- CC has three different tasks:
 - Isolation/fairness
 - Rate adjustment
 - Detecting congestion

Explicit Congestion Notification (ECN)

- Single bit in packet header; set by congested routers
 - If data packet has bit set, then ACK has ECN bit set
- Many options for when routers set the bit
 - tradeoff between (link) utilization and (packet) delay
- Congestion semantics can be exactly like that of drop
 - I.e., endhost reacts as though it saw a drop
- Advantages:
 - Don't confuse corruption with congestion; recovery w/ rate adjustment
 - Can serve as an early indicator of congestion to avoid delays
 - Easy (easier) to incrementally deploy
 - defined as extension to TCP/IP in RFC 3168 (uses diffserv bits in the IP header)

One final proposal: Charge people for congestion!

- Use ECN as congestion markers
- Whenever I get an ECN bit set, I have to pay \$\$
- Now, there's no debate over what a flow is, or what fair is...
- Idea started by Frank Kelly here in Cambridge
 - “optimal” solution, backed by much math
 - Great idea: simple, elegant, effective
 - Unclear that it will impact practice – although London congestion works



Some TCP issues outstanding...

Synchronized Flows

- Aggregate window has same dynamics
- Therefore buffer occupancy has same dynamics
- Rule-of-thumb still holds.

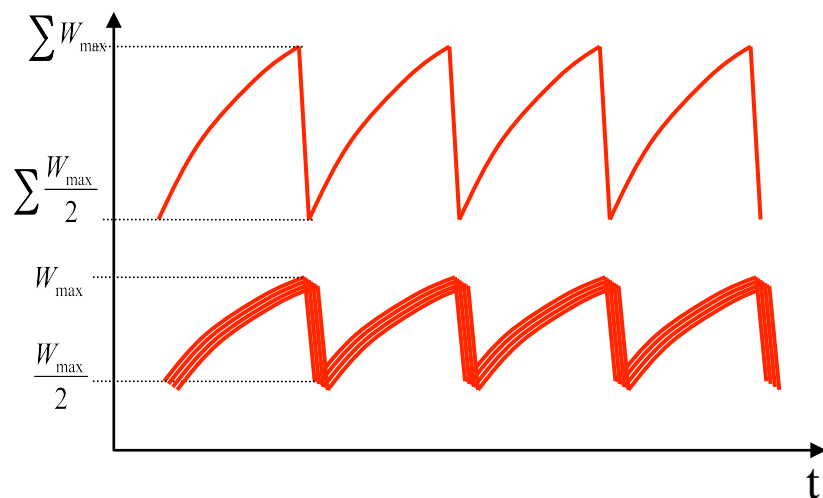

Many TCP Flows

- Independent, desynchronized
- Central limit theorem says the aggregate becomes Gaussian
- Variance (buffer size) decreases as N increases

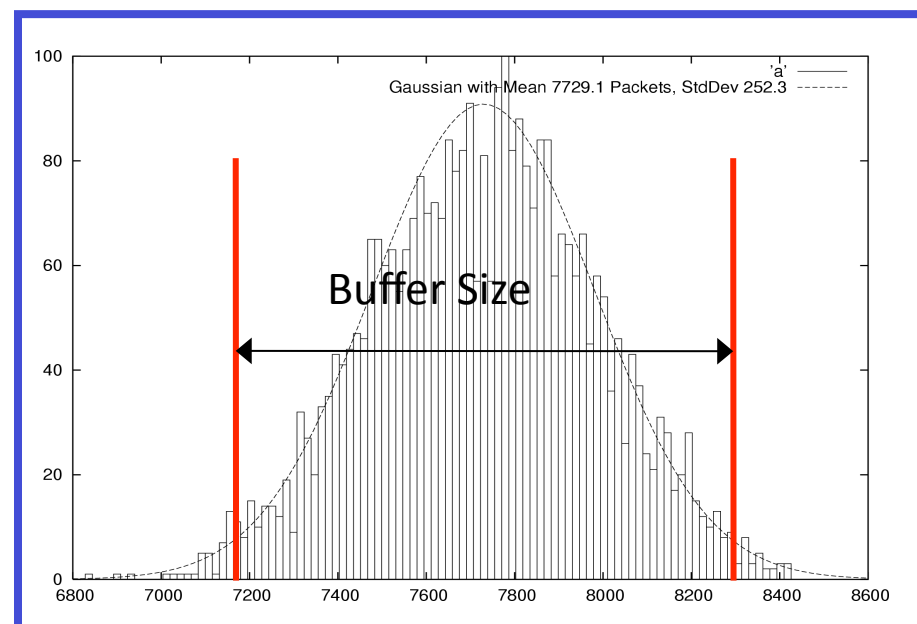

TCP in detail

- What does TCP do?
 - ARQ windowing, set-up, tear-down
- Flow Control in TCP
- Congestion Control in TCP
 - AIMD, Fast-Recovery, Throughput
- Limitations of TCP Congestion Control
- Router-assisted Congestion Control

Recap

- TCP:
 - somewhat hacky
 - but practical/deployable
 - good enough to have raised the bar for the deployment of new, more optimal, approaches
 - though the needs of datacenters might change the status quos