

Workshop One – Electronic Die

Introduction

The purpose of this lab is to build a simple electronic die using light emitting diodes (LEDs) as the display device. Digital logic chips will be used to implement the required functionality. You will construct the die on a prototyping breadboard that is housed in the 1A workshop prototyping box. Before you start wiring up the circuits, make sure you understand how the holes in the breadboard are connected and also how the pins are numbered on the logic chips – see the description in Appendix A.

Equipment and Components

1A Workshop Prototyping Box
Connecting wire
Red LEDs (7)
220 Ω resistors (7)
10k Ω resistor
74HC00 – Quad 2 input NAND gates (2)
74HC193 – Synchronous 4 bit up/down counter (1)

Step 1 – Wiring up one LED

First we need to see how to turn on one LED; note there will be seven in the completed die. If a LED is connected directly across the 5V power supply used to power the digital logic chips, it may well draw enough current to destroy itself. To prevent this happening we need to connect a current limiting resistor in series with the LED. The required circuit is below, followed by the calculation to select an appropriate value for the current limiting resistor, R.

Please make sure you use the correct value resistor, otherwise you may destroy the LED.

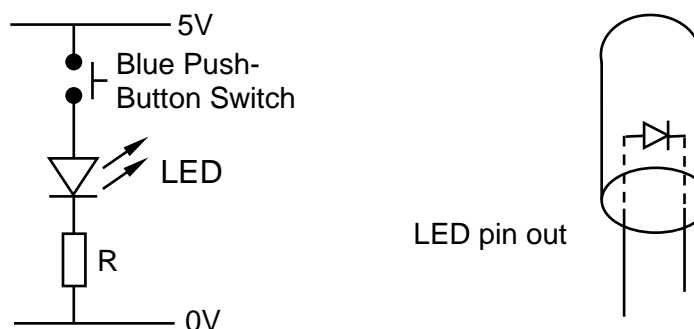

When the LED is lit correctly, the voltage across it will be about 1.6V and the current flowing through it should be about 15mA. To work out the appropriate value for R we need to use Ohm's law, i.e., $V = IR$. In this case the voltage across R is $(5 - 1.6)V$, so,

$$R = V/I = (5 - 1.6)/0.015 = 226\Omega.$$

Note that the nearest available value (known as the preferred value) is 220 Ω .

Task: Construct the above circuit and check that the LED lights when the button is pressed.

Step 2 – Binary to Die Decoder

To construct the die you will need to arrange the 7 LEDs in the following pattern to emulate the spots on a die.

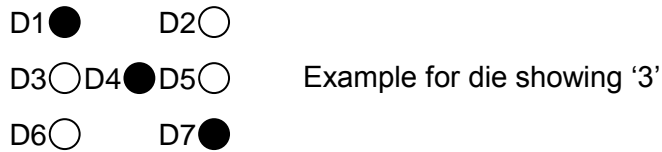

Task: Arrange the 7 LEDs on your breadboard to make the above pattern; making sure that each LED has a 220Ω resistor in series with it. Then construct the following circuit using a 74HC00 quad 2-input NAND chip, i.e., each chip contains 4 NAND gates. Test the circuit by connecting the 3 inputs to the toggle switches in the prototyping box. Remember to connect V_{cc} (pin 14) to 5V and GND (pin 7) to 0V. Also unused gate inputs must be connected to 0V to prevent unstable operation of the chips.

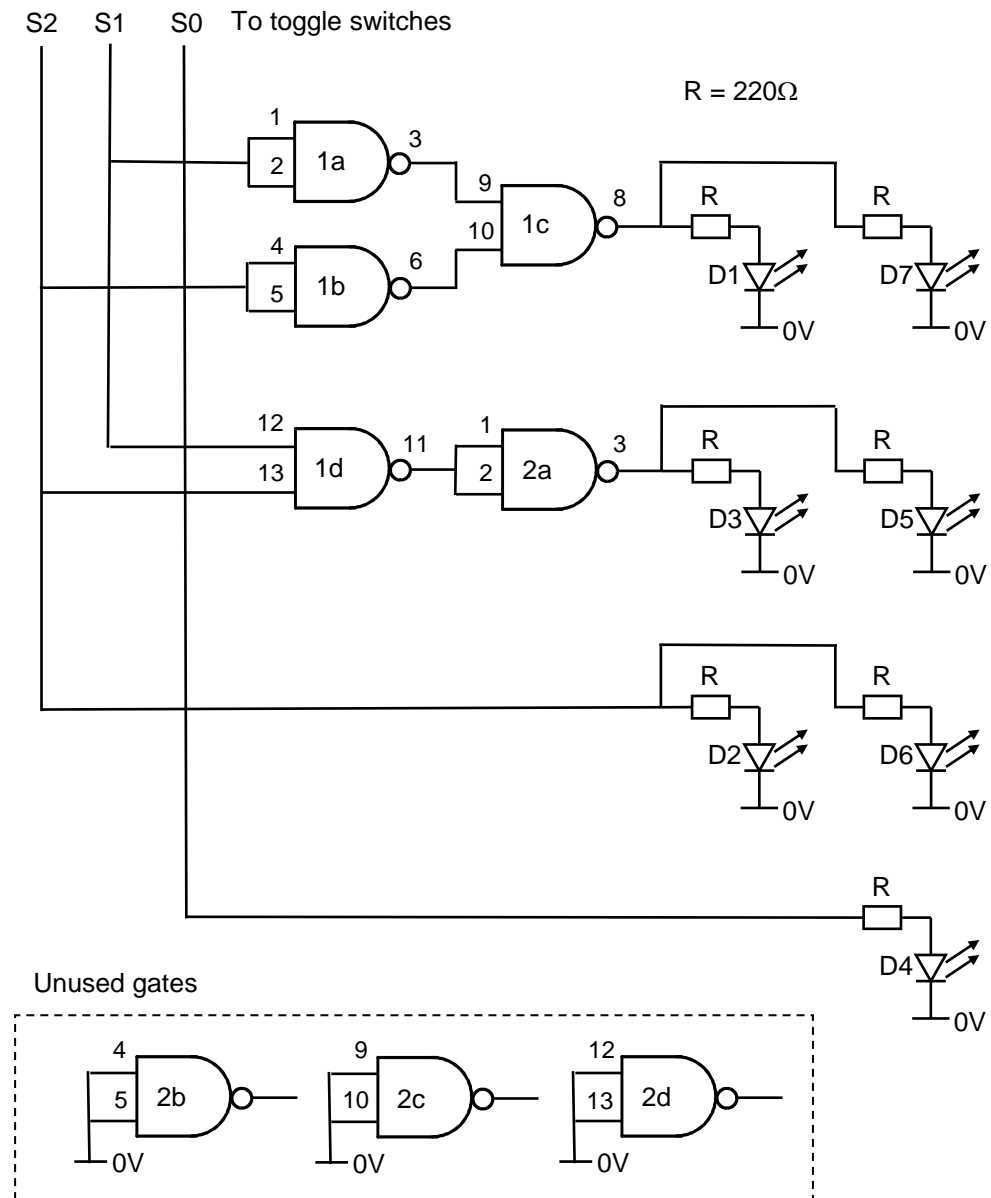

Step 3 – Make the die spin

Task: Use a 74HC193 counter chip as a replacement for the toggle switches. Wire up the circuit as shown below. Set the clock generator in the prototyping box to 100kHz. Note that to make the counter pausable, the 100 kHz clock is connected through one of the blue push button switches. Remember to disconnect S0, S1, S2 from the toggle switches and to connect them to the appropriate outputs from the counter, namely Q0, Q1, Q2. Also remember to connect V_{cc} (pin 16) to 5V and GND (pin 8) to 0V. You should now have a usable 8-sided die!

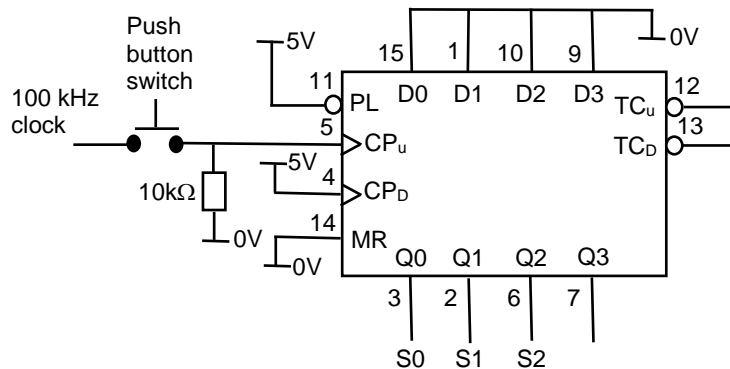

Optional Bonus Step

Task: Modify the previous circuit as shown below so that the die counts from 1 through 6. The decode logic detects the count of '7' and forces the counter to parallel load with the count of '1'.

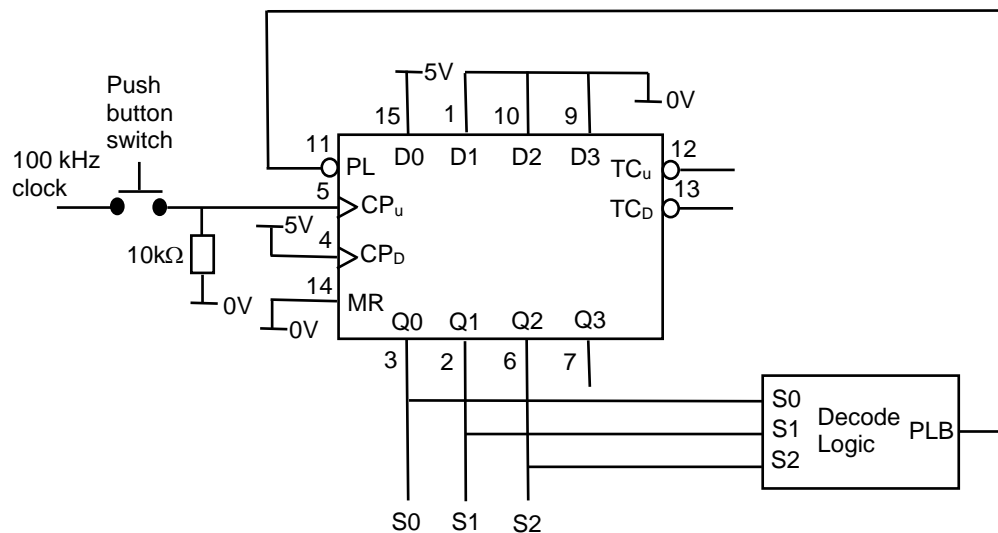

The decode logic has the following circuit diagram. Note that it uses the previously unused NAND gates from the original die design – remember to disconnect their inputs from 0V!

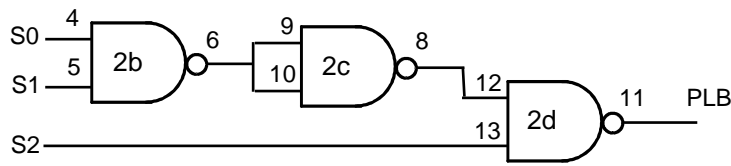

Assessment

Ticking criteria: Demonstrate that your 8-sided die works and answer the following questions.

Once your work has met the Common Ticking Criteria (see Introduction), get your work ticked by an assessor. Remember that you need to hand-in this assessment exercise as part of your portfolio of work (see Head of Department's notice).

In future workshops, it will be often be convenient to monitor the logical value of a signal using LEDs. Rather than wiring up discrete LEDs with serial resistors as we have done in this workshop, it will be more convenient to use the bank of 8 pre-wired LEDs which is available on the left hand side of the prototyping box.

Questions

1. What die patterns are displayed for binary inputs 000 and 111?
2. How much current can each NAND gate on the 74HC00 drive?
3. How would you arrange an LED (and resistor) so that it turns on when the output of a NAND gate is low?
4. How could this reduce the number of gates you have used?